

PROD		LOC	Q1ST	REVISIONS				DATE	APPD	
5066	DF	DO	P	F	ZONE	LTR	DESCRIPTION			
							REV PER 0600-6687-97	JY	8-14-98	JN

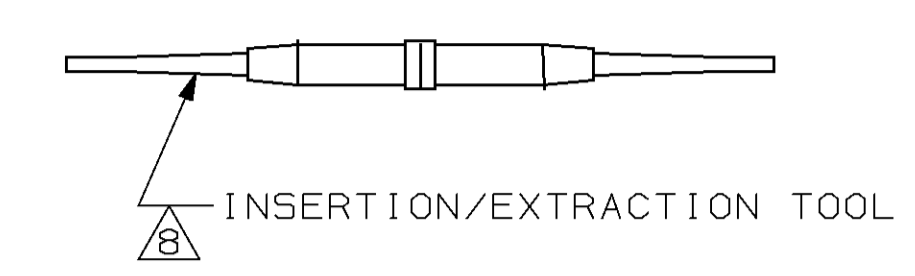

SOCKET CONTACT, SIZE 22, 62 REQD.
 BODY-MATL: BERYLLIUM COPPER PER QQ-C-530
 FINISH: PLATED GOLD .000050 MIN. THK.
 PER MIL-G-45204 OVER NICKEL .000050 MIN.
 THK. PER QQ-N-290
 HOOD-MAT'L: STAINLESS STEEL PER QQ-S-766
 FINISH: PASSIVATED PER QQ-P-35B

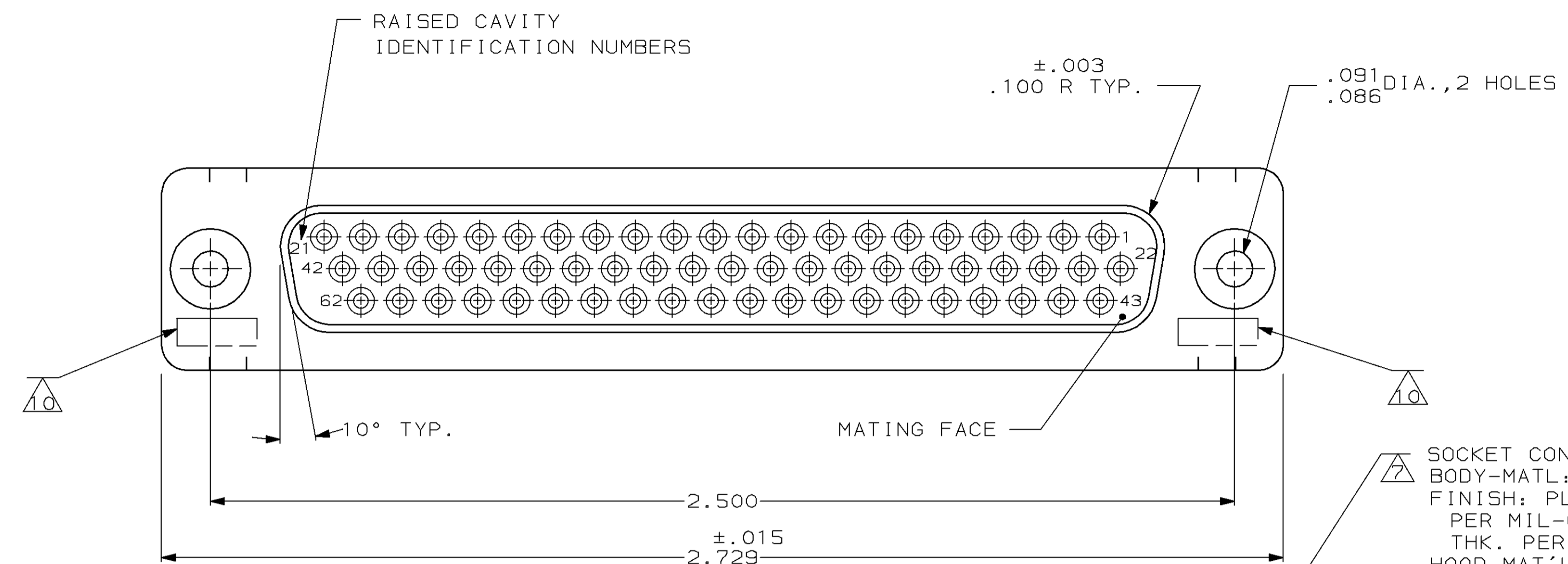
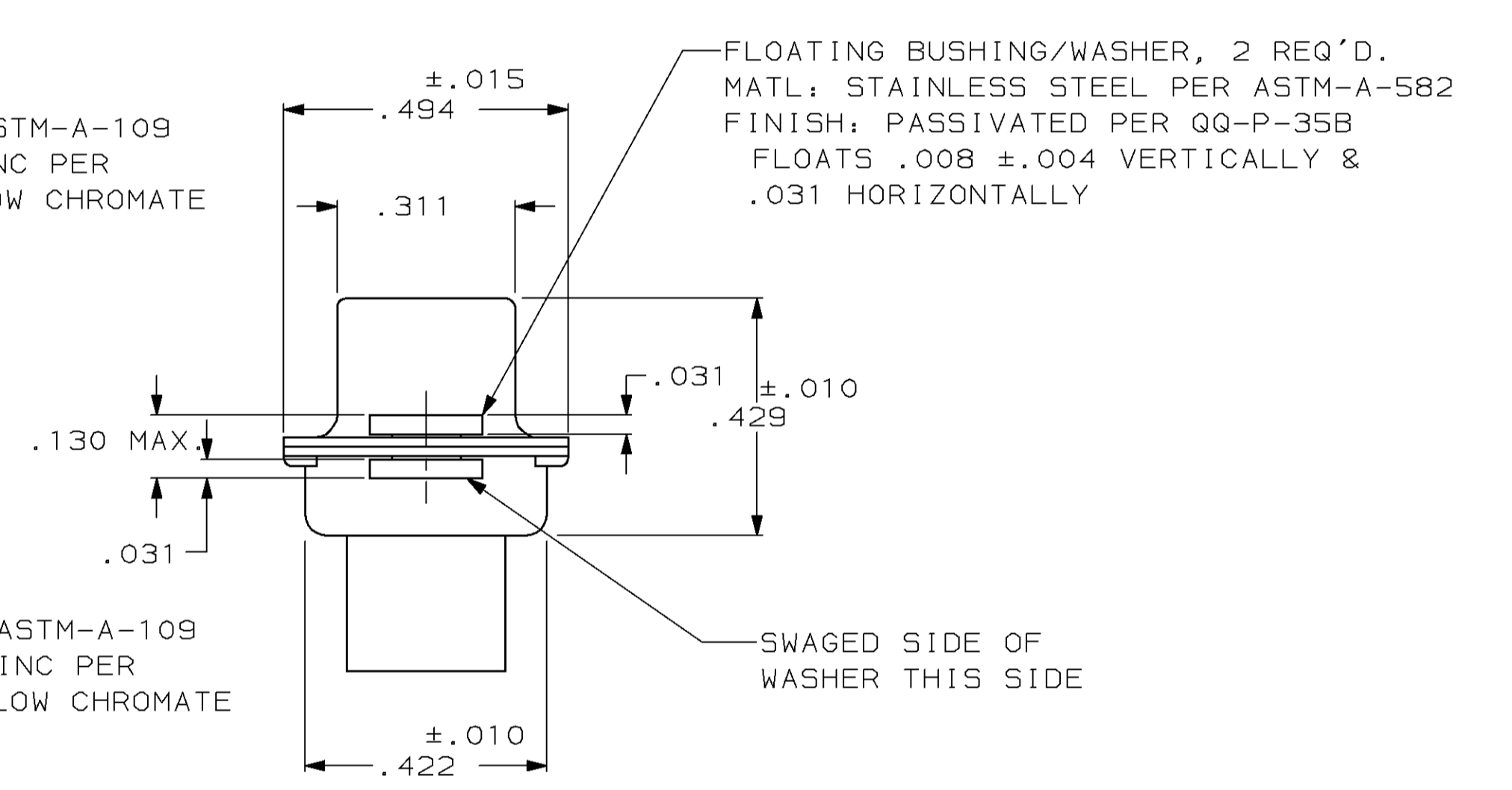
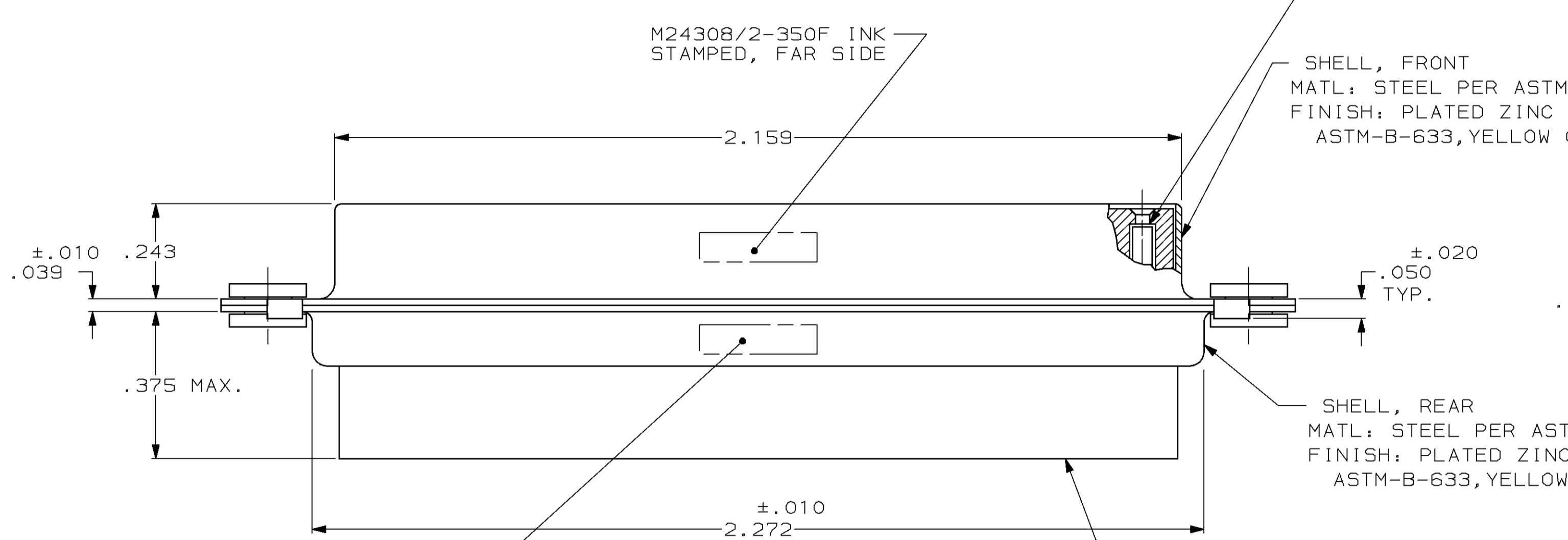

1. THIS RECEPTACLE WILL MATE WITH ANY 62 POSN., SIZE 4 PLUG IN AMPLIMITE SERIES.
2. MAXIMUM WIRE INSULATION TO BE USED WITH THIS RECEPTACLE IS .054 DIA.
3. SST RETENTION CLIPS ARE INCLUDED IN INSERTS.

- ④ PACKAGE STAMPED M24308/2-490F & AMP P/N 211539-1
- ⑤ PACKAGE STAMPED M24308/2-350F & AMP P/N 211539-2
- ⑥ PACKAGE STAMPED M24308/2-361F & AMP P/N 211539-3
- ⑦ AMP P/N 204351-1; MIL P/N 57-354, INCLUDED IN KIT
- ⑧ AMP P/N 91067-1; MIL P/N M81969/1-04
- ⑨ CONNECTOR SUPPLIED WITHOUT CONTACTS; SHOWN FOR ILLUSTRATION ONLY.
- ⑩ UL/CSA DESIGNATION STAMPED IN THIS AREA, OPTIONAL

SUPSD BY 204542-2 & 91067-1	SAME AS -1 EXCEPT: ⑥ ⑦ ⑧	211539-3
	SAME AS -1 EXCEPT: ⑤ ⑦	211539-2
	AS SHOWN ④ ⑨	211539-1

DESCRIPTION		PART NO		
DO NOT SCALE PRINT. UNLESS SPECIFIED DIMENSIONS IN INCHES TOLERANCES ON: 2 PLC DEC ± - 3 PLC DEC ± .005 ANGLES ± 0°30'	DR 7-1-85 D ERDMAN	AMP AMP INCORPORATED Harrisburg, Pa. 17105 NAME RECEPTACLE ASS'Y., AMPLIMITE, 62 POSN., SIZE 4, SERIES 90, W/DUAL FLOAT BUSHINGS		
SEE CALLOUT	CHK 9-20-85 R.GRZYBOWSKI			
SEE CALLOUT	APPD 9-20-85 L.ROPIER			
FINISH	APPD 9-20-85 G.SACUNAS	SIZE D	FSCM NO 00779	DRAWING NO 211539
SEE CALLOUT	APPLICATION SPEC -	SCALE NTS		SHEET 1 OF 1
	WEIGHT			