

REVISES		DATE	APPD
0	RELEASED	7-1-85	DE
A	REV-ECN DF-1034	MC	2-10-88

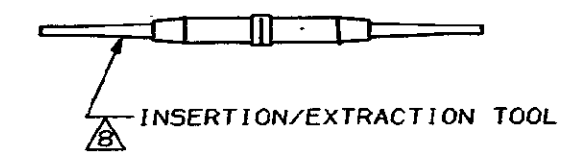

SOCKET CONTACT, SIZE 20, 25 REQ'D.
 BODY-MATL: BERYLLIUM COPPER PER QQ-C-530
 FINISH: PLATED GOLD $.000050$ MIN. THK.
 PER MIL-G-45204 OVER COPPER $.000100$ MIN.
 THK. PER MIL-C-14550
 HOOD-MAT'L: STAINLESS STEEL PER QQ-S-766
 FINISH: PASSIVATED PER QQ-P-35B

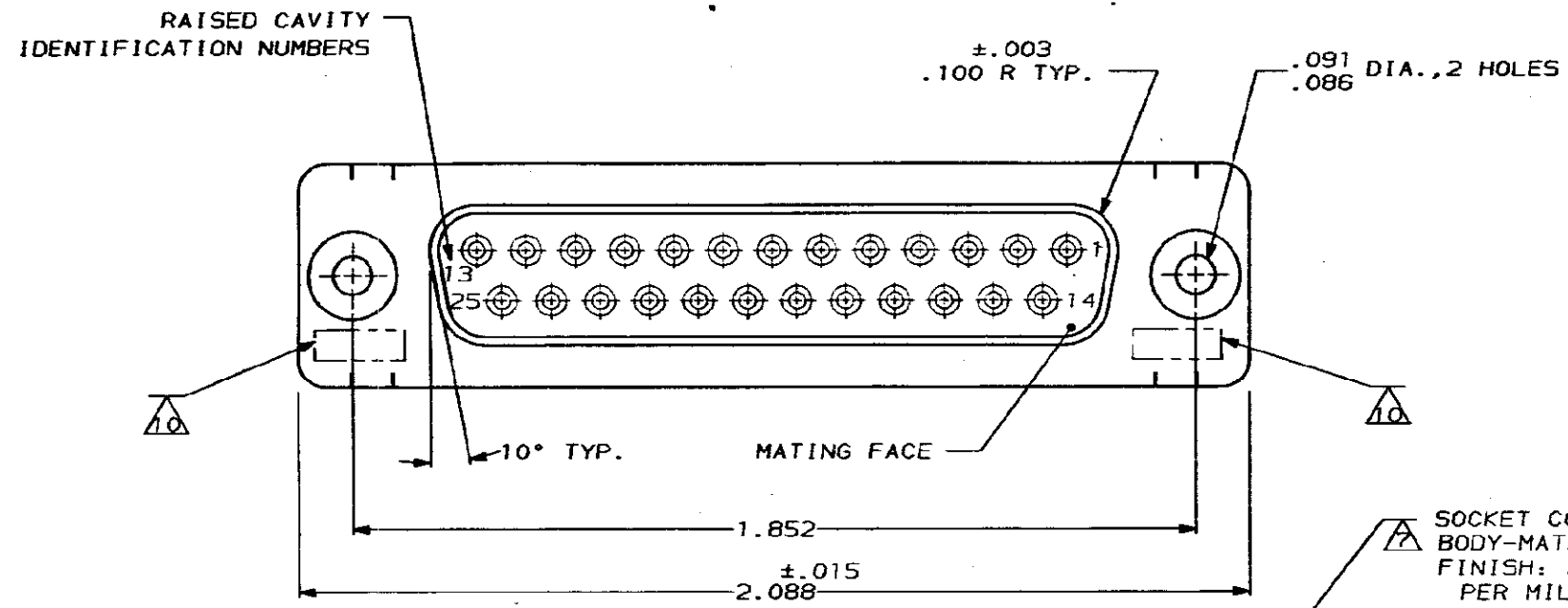
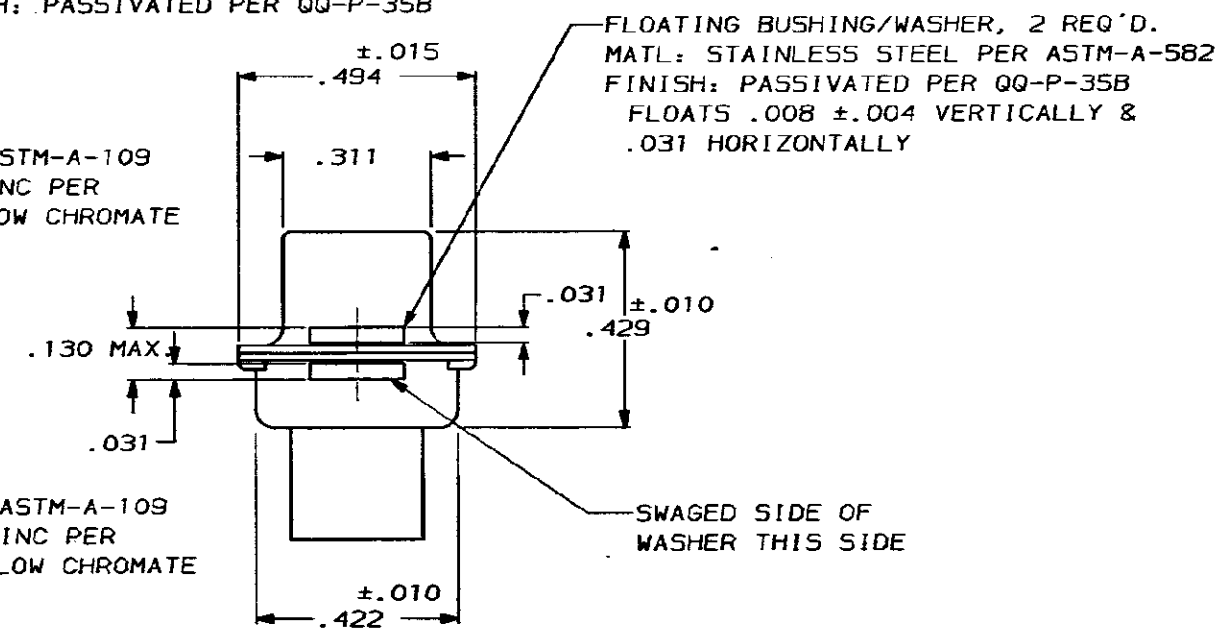
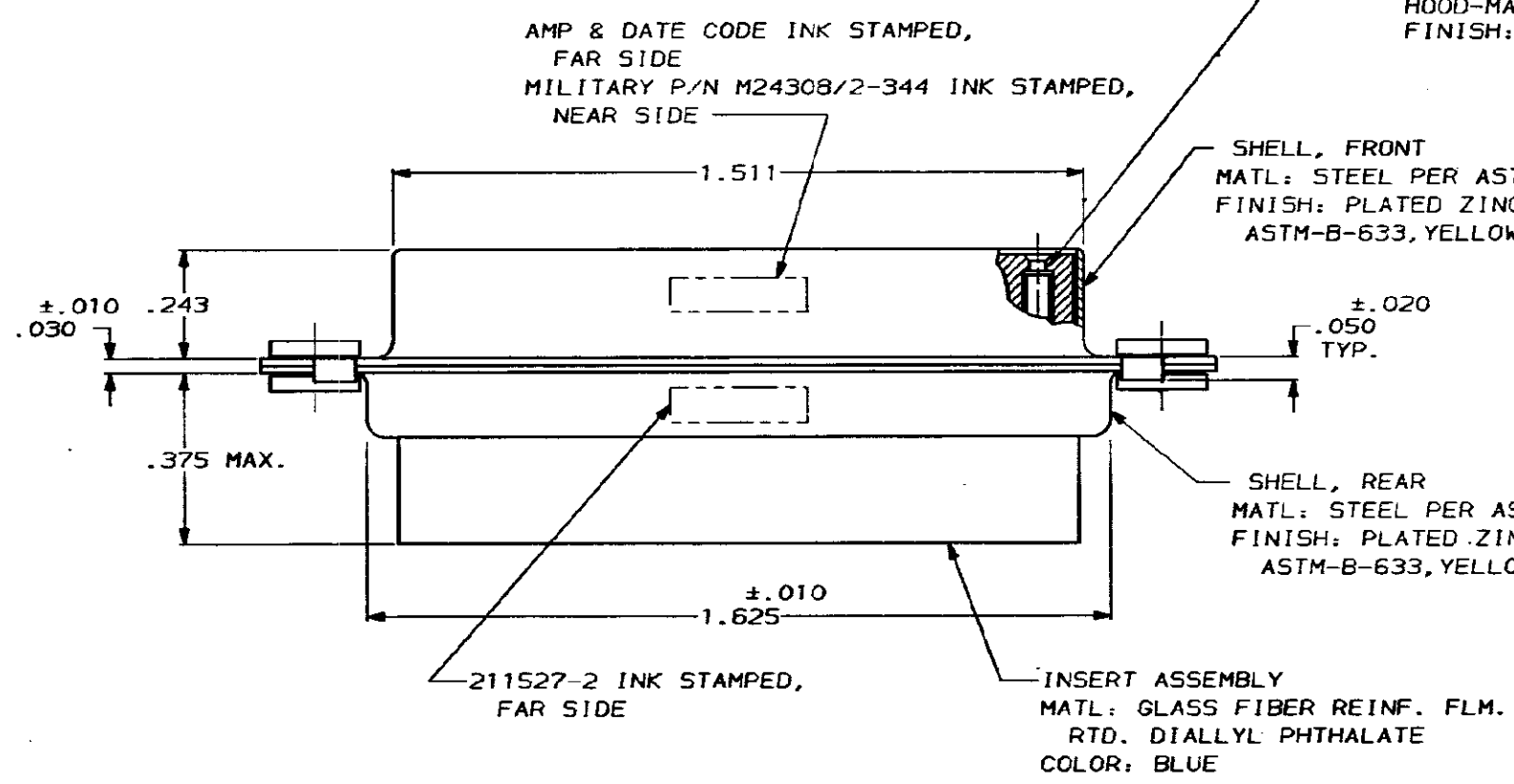

1. THIS RECEPTACLE WILL MATE WITH ANY 25 POSN., SIZE 3 PLUG IN AMPLIMITE SERIES.
2. MAXIMUM WIRE INSULATION TO BE USED WITH THIS RECEPTACLE IS $.068$ DIA.
3. SST RETENTION CLIPS ARE INCLUDED IN INSERTS.

- \triangle PACKAGE STAMPED M24308/2-484 & AMP P/N 211527-1
- \triangle PACKAGE STAMPED M24308/2-344 & AMP P/N 211527-2
- \triangle PACKAGE STAMPED M24308/2-355 & AMP P/N 211527-3
- \triangle AMP P/N 205090-1; MIL P/N 63-358, INCLUDED IN KIT.
- \triangle AMP P/N 91067-2; MIL P/N M81969/1-02.
- \triangle CONNECTOR SUPPLIED WITHOUT CONTACTS; SHOWN FOR ILLUSTRATION ONLY.
- \triangle UL/CSA DESIGNATION STAMPED IN THIS AREA.

SAME AS -1 EXCEPT: \triangle \triangle \triangle \triangle	DO
SAME AS -1 EXCEPT: \triangle \triangle \triangle \triangle	211527-2
AS SHOWN: \triangle \triangle \triangle \triangle	211527-1

DESCRIPTION		PART NO	
DO NOT SCALE PRINT. UNLESS SPECIFIED DIMENSIONS IN INCHES TOLERANCES ON: 2 PLC DEC = - 3 PLC DEC = $.005$ ANGLES $\pm 0^\circ 30'$		DR 6-18-85 D ERDMAN	
SEE CALLOUT		CHK 4-18-85 R. GRZYBOWSKI	
SEE CALLOUT		APPD 9-20-85 L. ROPIER	
FINISH		APPD 9-25-85 G. SACUNAS	
SEE CALLOUT		PRODUCT SPEC	
APPLICATION SPEC		SIZE	FSCM NO
WEIGHT		D	00779
		DRAWING NO	211527
		SCALE	NTS
		SHEET	1 OF 1

AMP | AMP INCORPORATED
 Harrisburg, Pa. 17105

NAME
 RECEPTACLE ASS'Y., AMPLIMITE
 25 POSN., SIZE 3, SERIES 109,
 W/DUAL FLOAT BUSHINGS