

RAISED CAVITY INDENTIFICATION NUMBERS

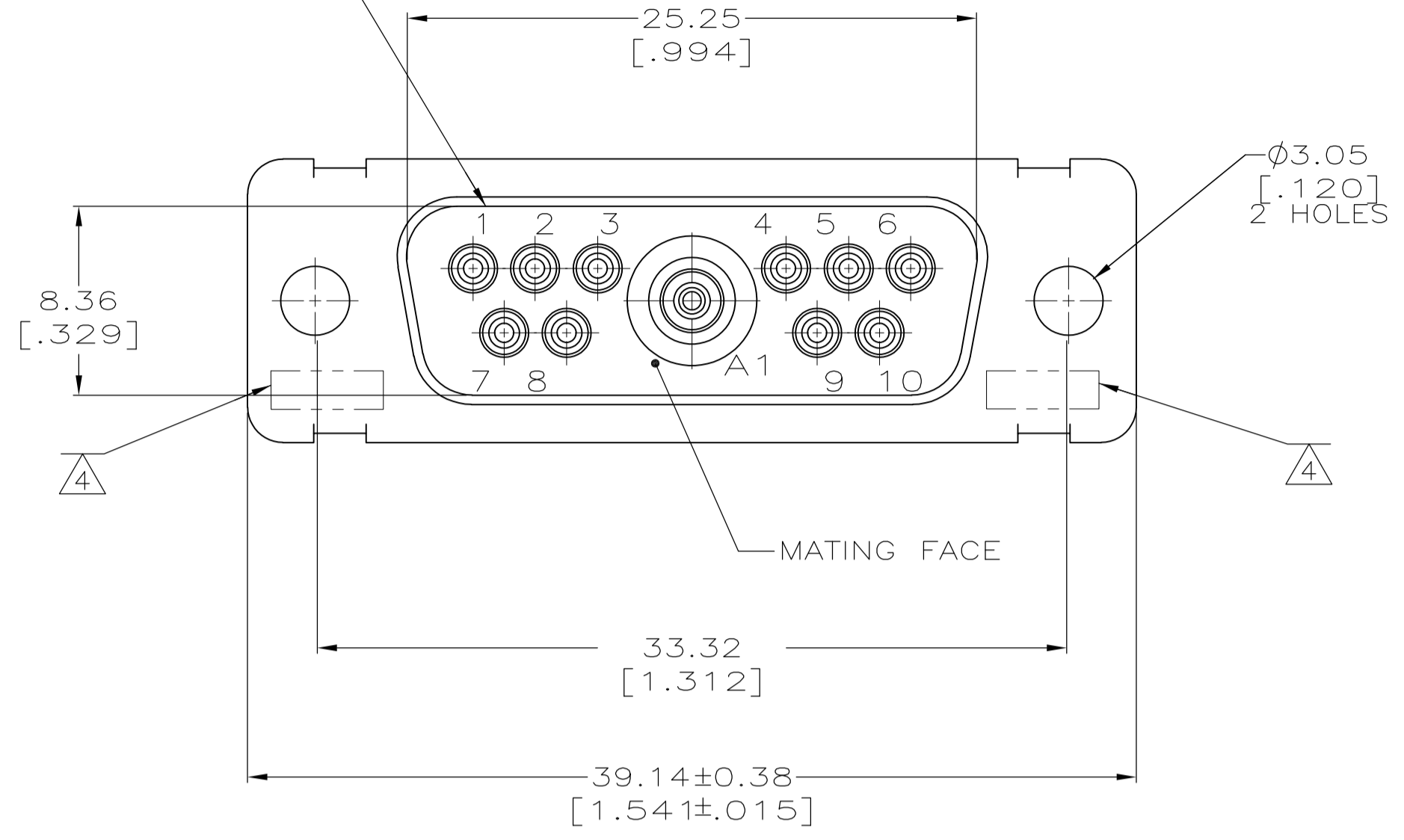

1. THE CONNECTORS DESCRIBED IN THIS DOCUMENT SHALL BE CAPABLE OF MEETING THE REQUIREMENTS OF 108-1770-1 AND MATE WITH ANY APPLICABLE RECEPTACLE CONNECTOR WITH SAME INSERT ARRANGEMENT.
- △ MARKED WITH 1.19[.047]-1.57[.062] HIGH CHARACTERS. FAR SIDE REFERS TO THE WIDE SIDE OF THE KEYSTONE. NEAR SIDE REFERS TO THE NARROW SIDE OF THE KEYSTONE. IF THE FRONT SHELL IS TOO SMALL FOR "AMP", TE PART NUMBER AND DATE CODE, THEN SPLIT AS FOLLOWS:
 - A. TE PART NUMBER ON REAR SHELL, FAR SIDE.
 - B. "AMP" AND DATE CODE ON FRONT SHELL, FAR SIDE.
- △ SPACERS (QTY 2) ARE SUPPLIED WITH CONNECTORS (NOT ATTACHED TO THE CONNECTOR).
- △ UL/CSA DESIGNATION STAMPED IN THIS AREA, OPTIONAL.
- △ FINISH: CADIUM PLATE PER QQ-P-416.
- △ FINISH: ZINC PLATED PER ASTM-B-633 .000200-.000400 THK WITH SUPPLEMENTARY CHROMATE (Cr3+).
- △ FINISH: IRIDATE PER MIL-C-5541, COLOR: GOLD.
- △ FINISH: SUPPLEMENTARY CHROMATE (Cr3+).

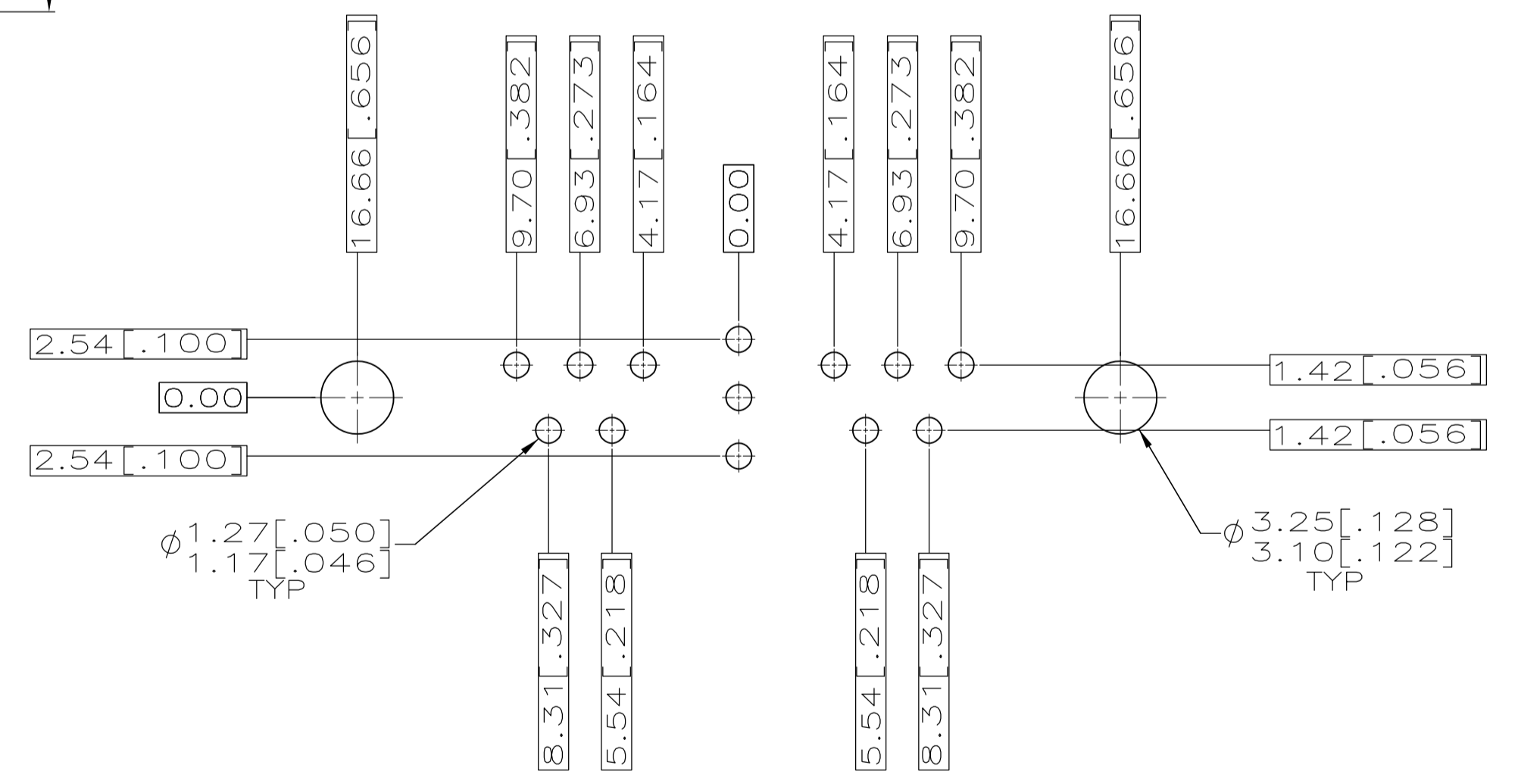
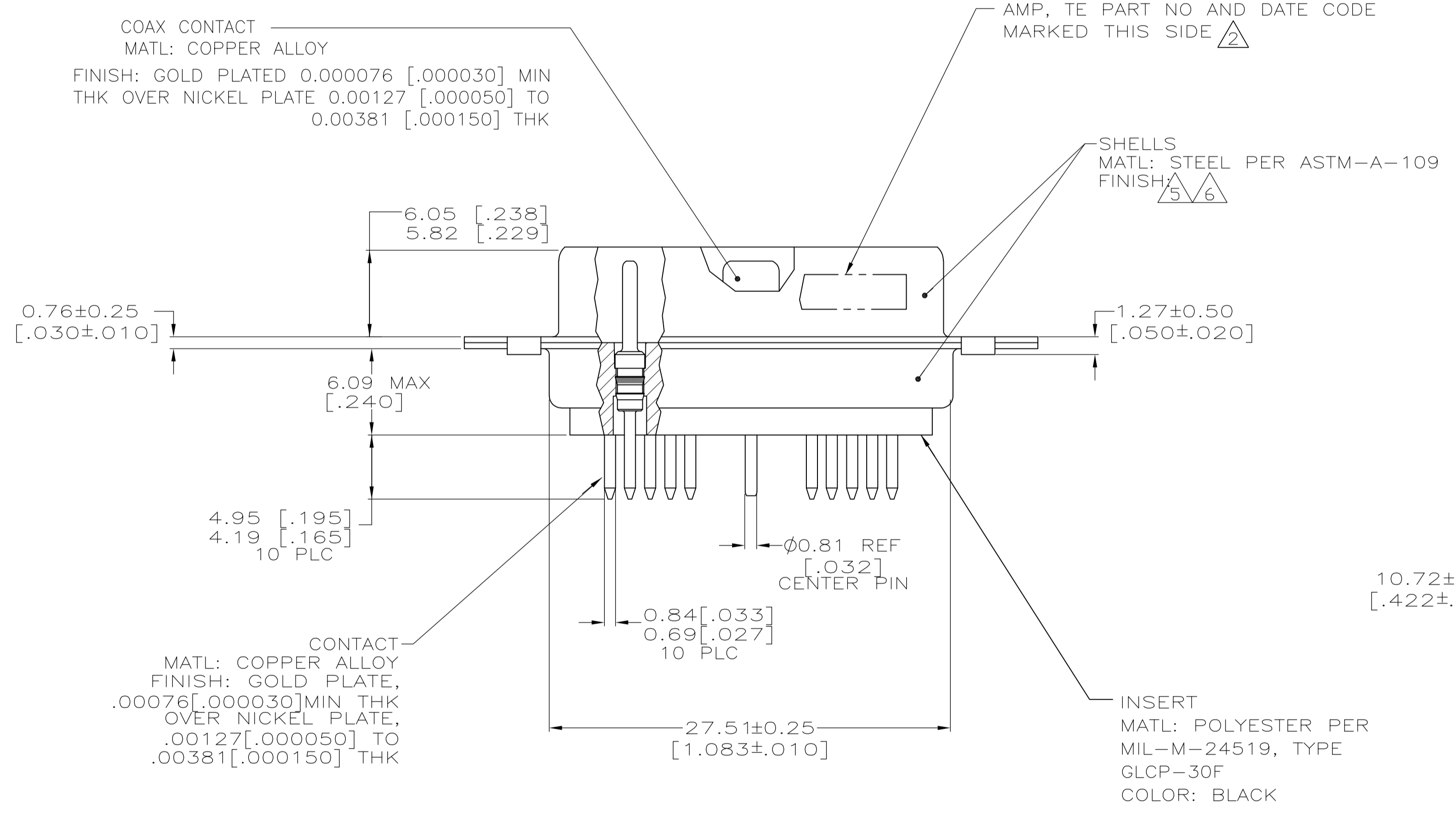

RECOMMENDED P.C. BOARD LAYOUT SHELL SIZE 2 (11C1 POSITION)

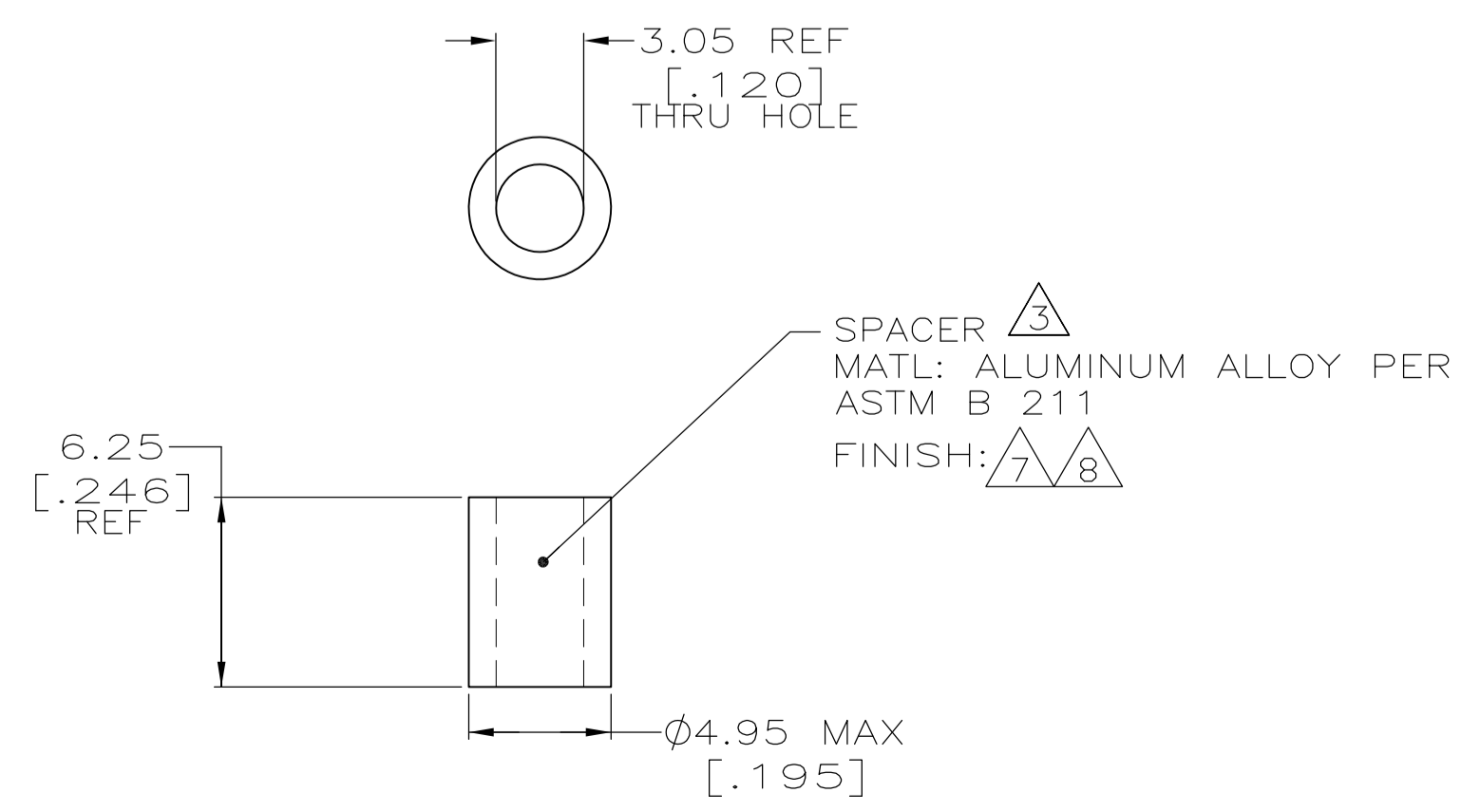

REMARKS	5-1218128-1
	1218128-1
	PART NUMBER

THIS DRAWING IS A CONTROLLED DOCUMENT.		DIN C.C. THOMAS 12-3-98	Tyco Electronics Corporation Harrisburg, PA 17105-3608	
DIMENSIONS: INCHES		CHK: D. MILLER 1-12-99	NAME: ASSY, AMPLIMITE, PLUG, 11C1 LOW PROFILE, SIZE 2, SERIES 109	
TOLERANCES UNLESS OTHERWISE SPECIFIED:		APVD: D. MILLER 1-12-99	SIZE: A1	
0 PLC ± -	1 PLC ± -	CAGE CODE: 00779		
2 PLC ± 0.3 [.01]	3 PLC ± 0.13 [.005]	DRAWING NO: 1218128		
4 PLC ± -	ANGLES ± -	SHEET 1 OF 1		
MATERIAL: SEE CALLOUTS		FINISH: SEE CALLOUTS		REV F
WEIGHT: -		SCALE: 4:1		
CUSTOMER DRAWING				