

NOTE

All numerical values are in metric units [with U.S. customary units in brackets]. Dimensions are in millimeters [and inches]. Unless otherwise specified, dimensions have a tolerance of ± 0.13 [.005] and angles have a tolerance of $\pm 2^\circ$. Figures and illustrations are for identification only and are not drawn to scale.

1. INTRODUCTION

This specification covers the requirements for application of AMP* PICABOND Regular and Weather Resistant Mini Connectors. These requirements apply to hand actuated or automated tools. The connectors consist of an insulated open-barrel, metal channel with two sets of slotted lances protruding from the base of the channel. Sidewalls of the connector are composed of many shaped elements (legs and Stuffers). Elements serve to hold and stuff the wires positioned between the sidewalls into the slots formed by the lances, during the crimping cycle. This document supersedes Application Specification 114-6012.

PICABOND connectors provide an economical and reliable means to arrange large splices in pedestals and closures, allowing easy re-entry for re-arrangements and ready identification of pairs. The connectors eliminate the requirement of stripping or cutting of wire ends.

Precision applicator tooling automatically trims wires to lengths during the crimping cycle, while within each connector, two sets of double lances displace the wire insulation, providing two reliable electrical contact points for each wire. The sides of the connector are crimped over the wires proving a mechanically strong connection.

When corresponding with AMP personnel, use the terminology provided on this specification to help facilitate your inquiry for information. Basic terms and features of components are provided in Figure 1.

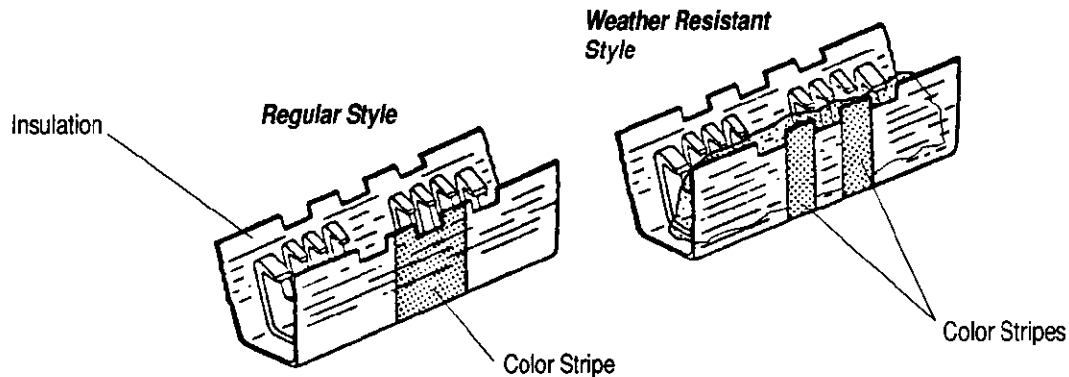

Figure 1

2. REFERENCE MATERIAL**2.1. Revision Summary**

This paragraph is reserved for a revision summary covering the most recent additions and changes made to this specification which include the following:

Per EC 0990-0568-96

- Described splice differences
- Added 108-6009 as a reference
- Added statement indicating use of plastic cable per EC 0230-0237-95
- Expanded tooling to include crimp tooling reference documentation
- Included visual aid

2.2. Customer Assistance

Reference Part Number 552043 and Product Code 1205 are representative numbers that identify PICABOND Regular and Weather Resistant Mini Connectors. Use of these numbers will identify the product line and expedite your inquiries through an AMP service network established to help you obtain product and tooling information. Such information can be obtained through a local AMP Representative (Field Sales Engineer, Field Service Engineer, etc.) or, after purchase, by calling the Tooling Assistance Center or the AMP FAX/Product Information number at the bottom of page 1.

2.3. Drawings

Customer Drawings for specific products are available from the responsible AMP Engineering department via the service network. The information contained in the Customer Drawings takes priority if there is a conflict with this specification or with any other technical documentation supplied by AMP Incorporated.

2.4. Specifications

AMP Product Specification 108-6009 provides applicable performance requirements for PICABOND Regular and Weather Resistant Mini Connectors.

2.5. Instruction Material

The following AMP Instruction Sheets (408-Series) are supporting documents available to assist with product application, and tool setup and operation.

- 408-6539 Application and Maintenance for AMP model MVS-3 Hand Tool Kit 244271-3
- 408-7445 Installing PICABOND Mini Connectors with AMP MA-10 Applicator 229528-5 or 229528-1
- 408-7306 Installing PICABOND Mini Connectors with AMP Model MR-1 Hand Tool 251101-1

3. REQUIREMENTS

3.1. Wire Preparation

A. Wire Size

PICABOND Mini Connectors will accept solid copper wires ranging in size from 19 to 28 AWG.

B. Wire Insulation Diameter

Wire insulation diameter shall be as shown in Figure 2.

C. Wire Insulation

Wire insulation may be plastic, pulp, or paper.

TYPE	PART NUMBERS †		WIRE SIZE (AWG)	COLOR CODE	WIRE INSULATION	
	STRIP▪	LOOSE PIECE▪▪			MATERIAL††	OUTSIDE DIA RANGE
REGULAR	552466-3 [-1]	552466-4 [-2]	28-24	PINK	NON-FILLED PLASTIC, PAPER, OR PULP	0.38-1.17 [.015-.046]
	552041-3 [-1]	552041-4 [-2]	26-22	BLUE		0.46-1.22 [.018-.048]
	552043-3 [-1]	552043-4 [-2]	24-19	BROWN		1.17-2.03 [.046-.080]
WEATHER RESISTANT	552439-2 [-1]	--	26-22	BLUE / WHITE	FILLED PLASTIC	0.46-1.22 [.018-.046]
	552440-2 [-1]	--	24-19	BROWN / WHITE		1.17-2.03 [.046-.080]

† [-1] and [-2] represent PICABOND International part numbers.

†† Insulation type listed is preferred; for other applications consult AMP FAX*/PRODUCT INFO 1-800-522-6752.

▪ Model MA-10 applicator 229534-1 are used for strip form connectors.

▪▪ Model MVS-3 Hand Tool 244271-3 is used for mini loose piece connectors and Model MR-1 Hand Tool 251101-1 is used for regular loose piece connectors.

Figure 2

3.2. Crimp Inspection

Contacts shall be crimped in accordance with specifications supplied with tooling. Only one wire will be used per connector end.

A. Wire Protrusion

Bare wires shall not protrude from the center of the connector after termination. A small tuft of insulation is not a defect as long as bare wire is not visible.

B. Workmanship

Care shall be taken not to cut, score, or crush the connector. Such conditions are due to foreign matter in crimper dies or on anvil and also misalignment of the tooling.

C. Crimp Height (Gaging)

Within a short time of crimping, measure the crimped connector using AMP gage tool 229642-1 as shown in Figure 3.

1. Select the proper gage end by matching gage color dot with color on connector.
2. Insert and center the connector in the gage.
3. Hold the wire and slide the gage on the connector— little or no drag should be noticed. If the connector sticks in the gage, make two sample crimps using scrap wire. Gage them immediately. If they stick, inspect the the tool for defects and verify proper AWG wire size and connector color coding. Otherwise, return the tool for repair.
4. Visually inspect contacts for defects such as the corner of the insulation peeled back, protruding wires, cut or score marks in the insulation, and crushed or distorted connectors as shown in Figure 3.

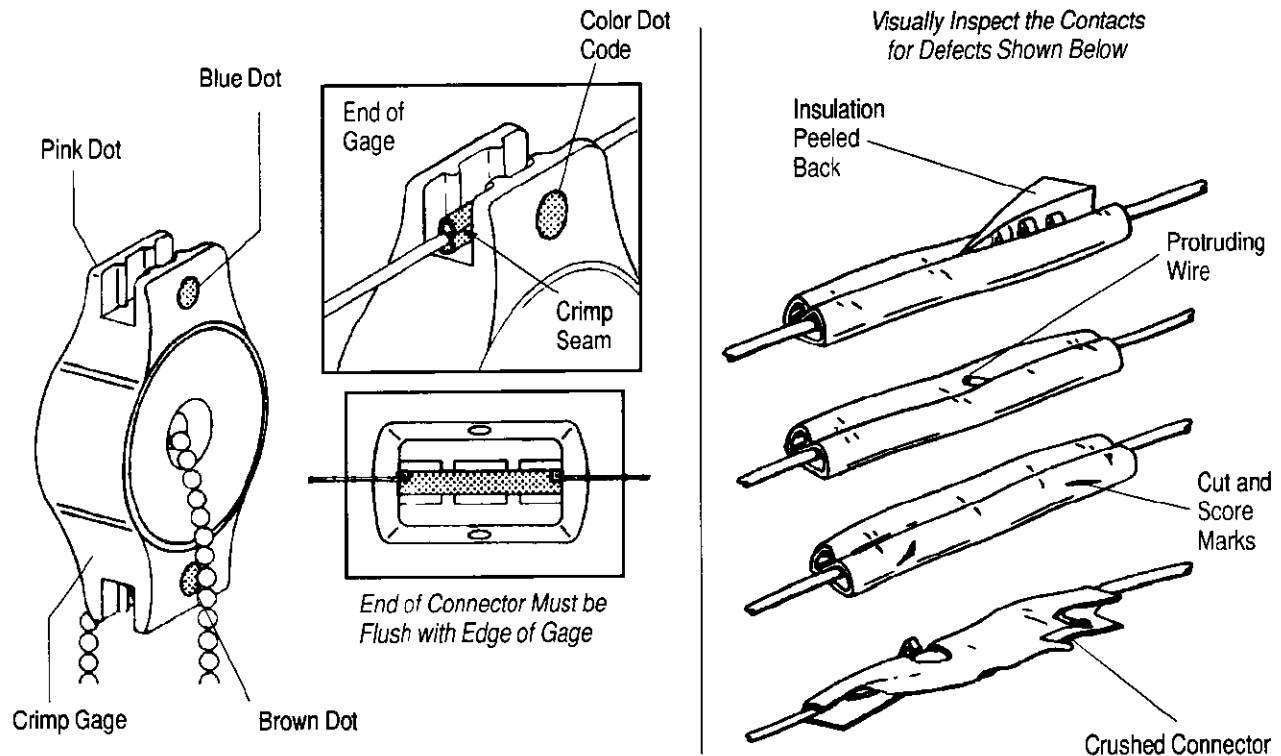

Figure 3

4. QUALIFICATIONS

AMP PICABOND Regular and Weather Resistant Mini Connectors (International) are not required to be listed or recognized by Underwriters' Laboratories, Inc. (UL), or the Canadian Standards Association (CSA).

5. TOOLING (Figure 4)

The AMP Model MR-1 Hand Tool 251101-1 and Model MVS-3 Hand Tool Kit 244271-3 are designed to join cable conductors (wires) using loose piece form PICABOND Mini connectors. Model MA-10 applicator 229528-5 or -1 is used for strip form connectors. Gaging Tool 229642-1 is used for measuring PICABOND connector crimp heights.

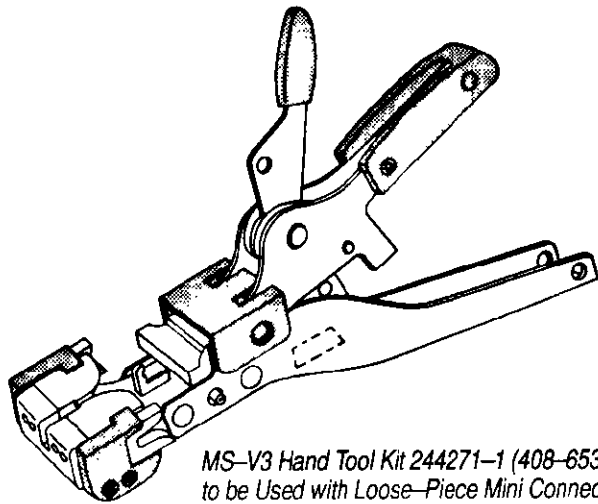

*MS-V3 Hand Tool Kit 244271-1 (408-6539)
to be Used with Loose-Piece Mini Connector*

*AMP Gaging Tool 229642-1
Used for Connector Crimp Inspection*

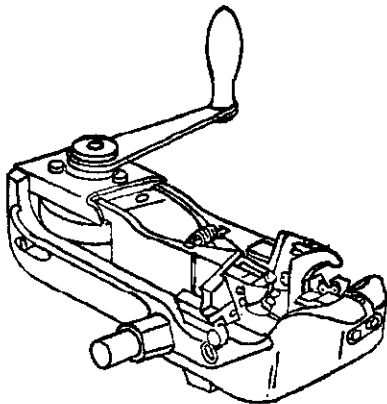
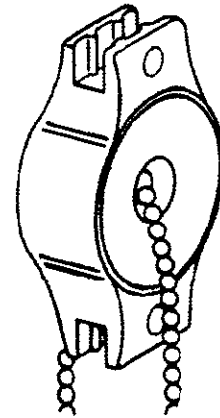

*MA-10 Applicator Kit 229528-1 or -5 (408-7445)
to be Used with Strip Form Mini Connector*

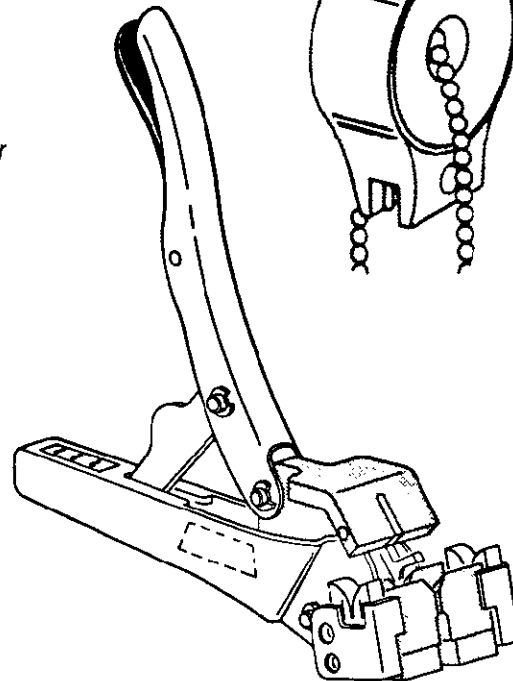

*MR-1 Hand Tool 251101-1 (408-7306)
to be Used with Mini Loose Piece Connectors*

Figure 4

6. VISUAL AID

The following illustrations are to be used by production personnel to ensure properly applied product. The views suggest requirements for good applications. Applications considered visually incorrect should be inspected using the information in the main body of this document. See Figure 5.

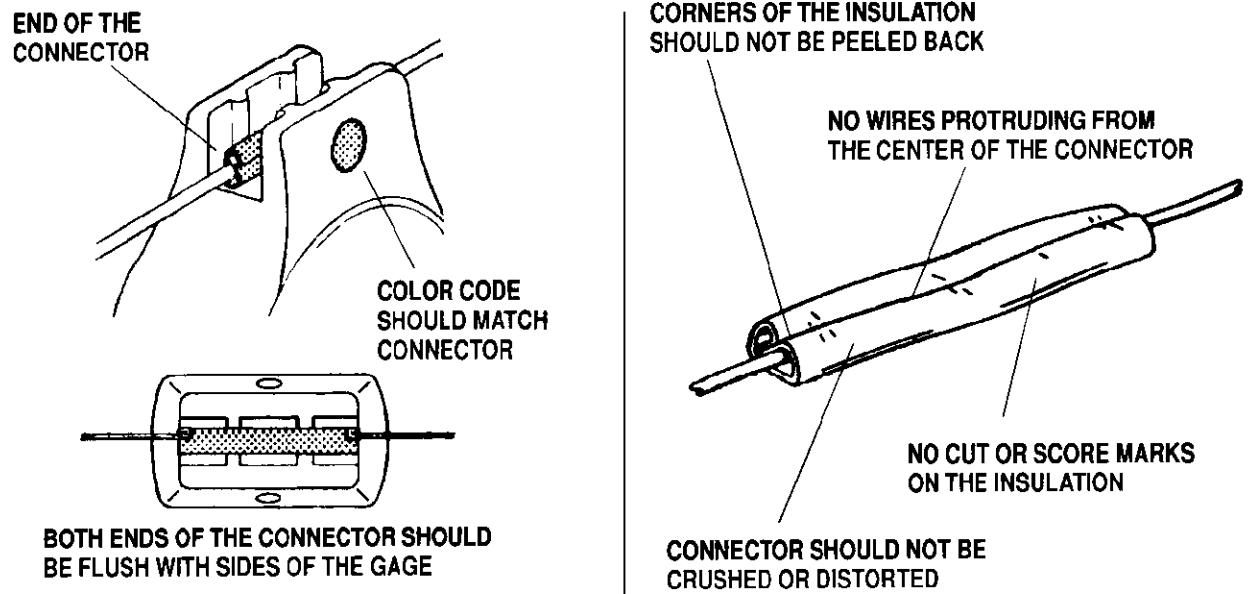

FIGURE 5. VISUAL AID