

THIS DRAWING IS UNPUBLISHED. RELEASED FOR PUBLICATION
 © COPYRIGHT BY TYCO ELECTRONICS CORPORATION. ALL RIGHTS RESERVED.

LOC	DIST	REVISIONS			
P	LTR	DESCRIPTION	DATE	DWN	APVD
AF	50				
	T	REVISED PER 0G3A-0170-05	30JUN05	MF	EH
	T1	REVISED PER ECO-09-021510	04SEP09	KK	AEG

- 1 OPERATION TEMPERATURE IS 105° C MAX.
- 2 RETENTION FORCE - 16 OUNCES MIN INITIALLY.
6 OUNCES MIN AFTER 500 CYCLES.
- 3 REFER TO MOUNTING HOLE PATTERN.
- 4 .175 MAX TO BE MEASURED ACROSS THE CUT-OFF TABS.
- 5 OBSOLETE PARTS: OBSOLETE CIS STREAMLINING PER D.RENAUD/D.SINISI

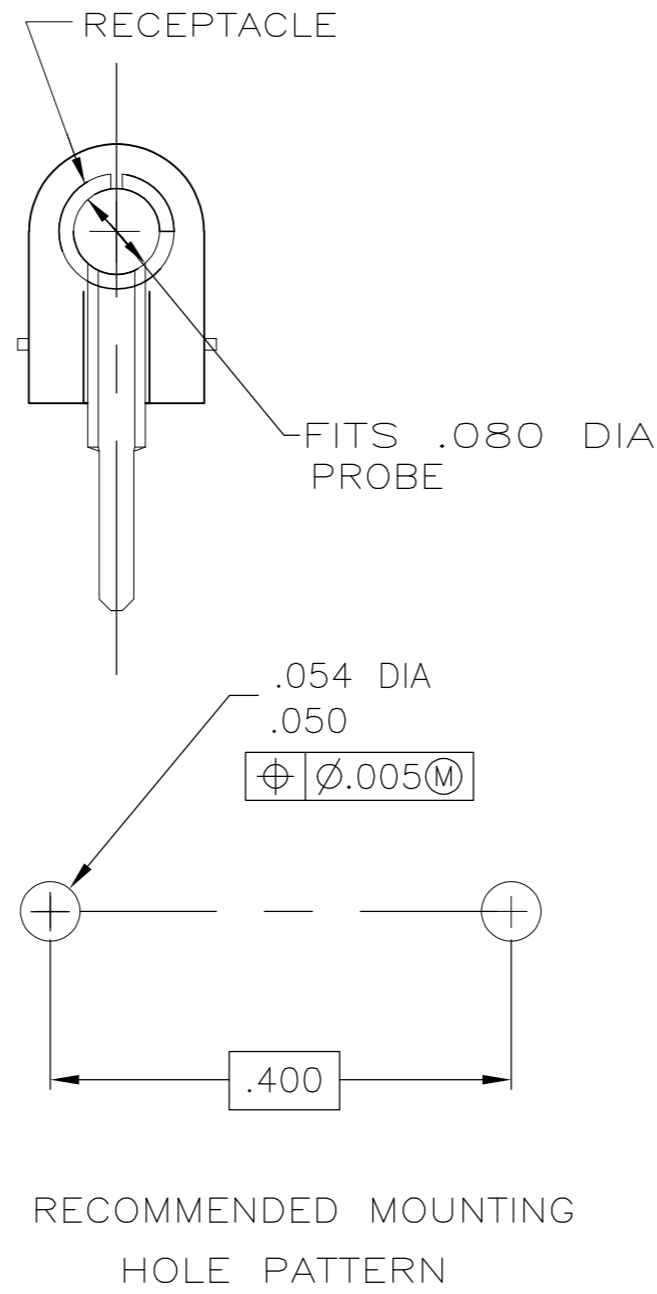
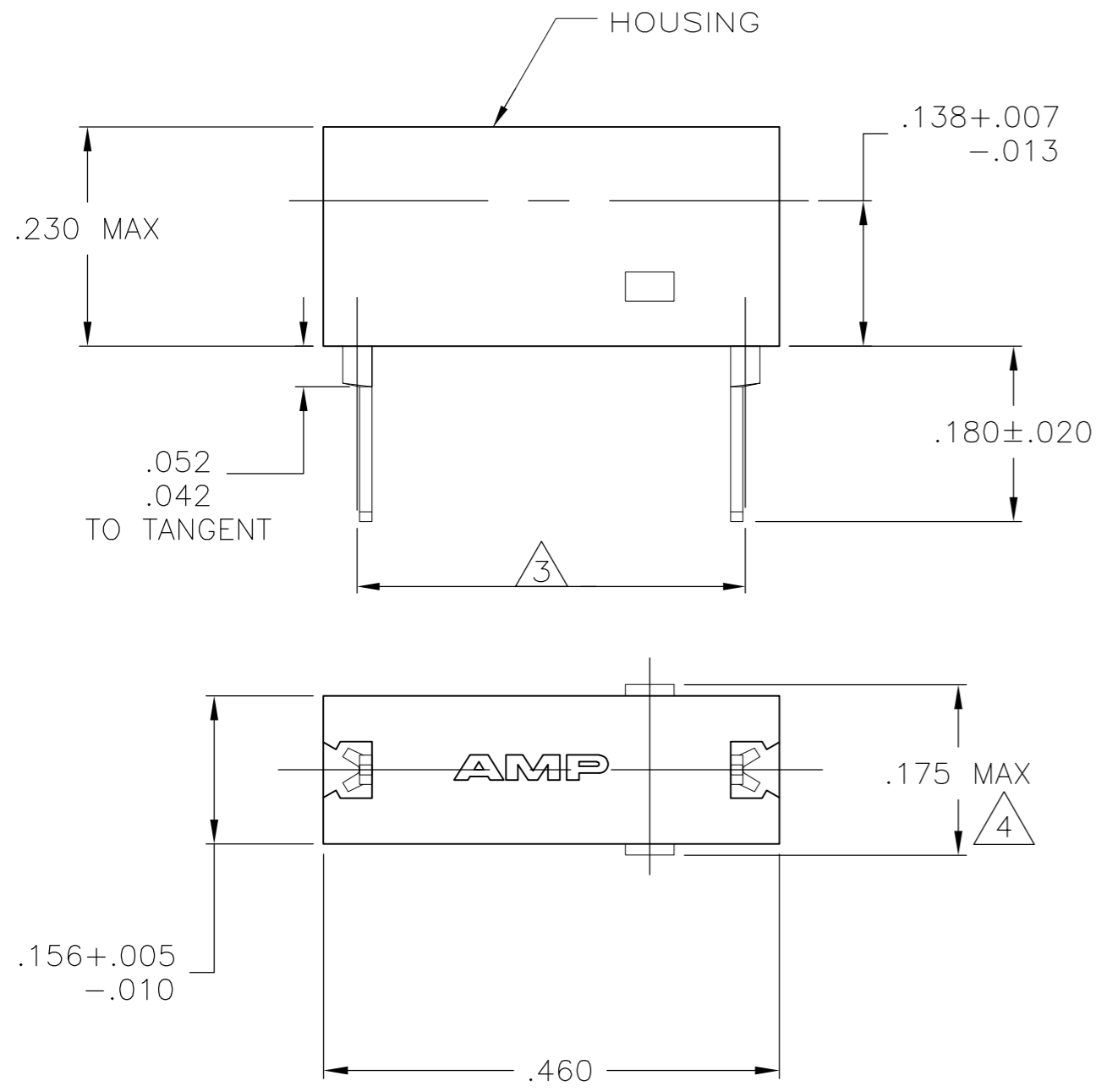

5	SUPERCEDED	NYLON 6/6; GREEN	BRASS - TIN-LEAD	3-380736-5
	OBSOLETE	NYLON 6/6; NATURAL	BRASS - GOLD	2-380736-0
		NYLON 6/6; WHITE	BRASS - GOLD	1-380736-9
	OBSOLETE	NYLON 6/6; GRAY	BRASS - GOLD	1-380736-8
	OBSOLETE	NYLON 6/6; VIOLET	BRASS - GOLD	1-380736-7
	OBSOLETE	NYLON 6/6; BLUE	BRASS - GOLD	1-380736-6
	OBSOLETE	NYLON 6/6; GREEN	BRASS - GOLD	1-380736-5
	OBSOLETE	NYLON 6/6; YELLOW	BRASS - GOLD	1-380736-4
	OBSOLETE	NYLON 6/6; ORANGE	BRASS - GOLD	1-380736-3
	OBSOLETE	NYLON 6/6; RED	BRASS - GOLD	1-380736-2
	OBSOLETE	NYLON 6/6; BROWN	BRASS - GOLD	1-380736-1
		NYLON 6/6; BLACK	BRASS - GOLD	1-380736-0
		HOUSING - MATERIAL; COLOR	RECEPTACLE - MATERIAL; FINISH	PART NUMBER

THIS DRAWING IS A CONTROLLED DOCUMENT.		DWN M.S. FEHER 19APR2004	Tyco Electronics Corporation Harrisburg, Pa 17105-3608	
DIMENSIONS: mm		CHK E. HOWARD 19APR2004	NAME ASSEMBLY, TEST PROBE	
TOLERANCES UNLESS OTHERWISE SPECIFIED: 0 PLC ± - 1 PLC ± - 2 PLC ± .015 3 PLC ± - 4 PLC ± - ANGLES ± -		APVD E. HOWARD 10APR2004	PRODUCT SPEC APPLICATION SPEC	
MATERIAL SEE TABLE	FINISH SEE TABLE	WEIGHT -	SIZE A2	CAGE CODE 00779
CUSTOMER DRAWING		SCALE 6:1	DRAWING NO C=380736	RESTRICTED TO -
		SHEET 1	OF 1	REV T1