

LOC	DIST	REVISIONS					
E	B	P	LTR	DESCRIPTION	DATE	DWN	APVD
			BA	NEW RELEASE	17-NOV-08	SM	St.P

FOR FURTHER INFORMATION SEE DATA SHEET FOR  
5930 SERIES-PROFESSIONAL TRIMMERS

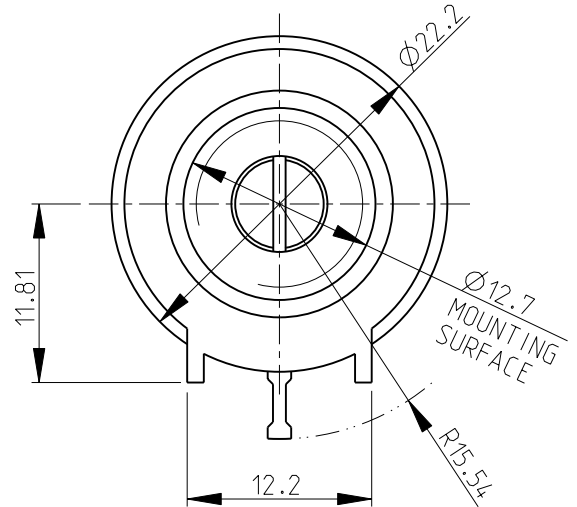

RoHS Compliant

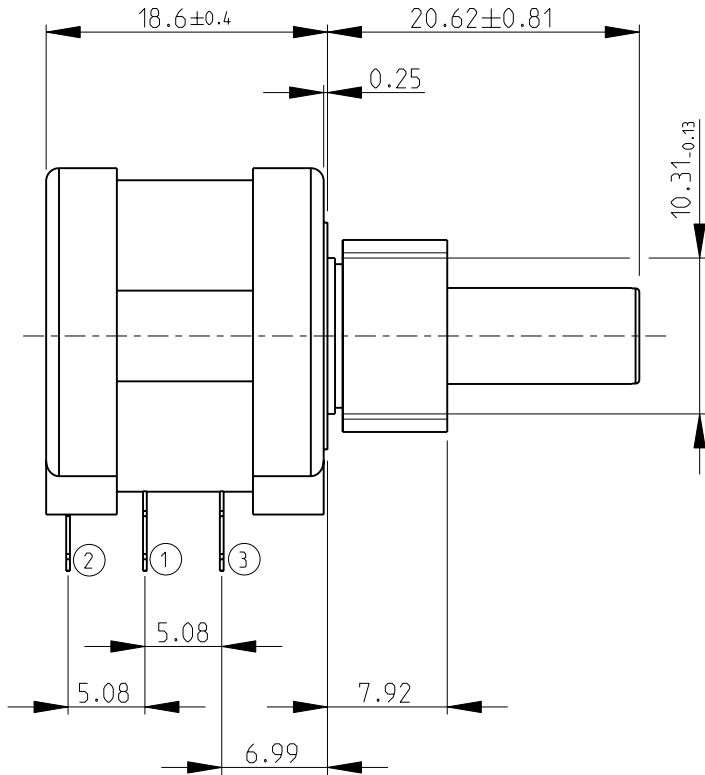
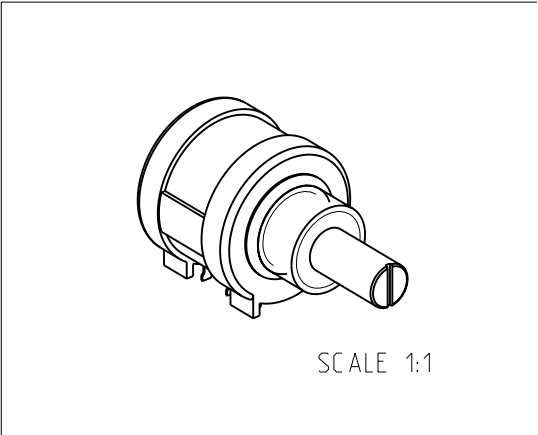

2008

RELEASED FOR PUBLICATION

THIS DRAWING IS UNPUBLISHED.

© COPYRIGHT 2008 BY TYCO ELECTRONICS CORPORATION. ALL RIGHTS RESERVED.

DIMENSIONS: mm	DWN	SUBHASH.M	17-NOV-08	MATERIAL	-	FINISH	-			
	CHK	PRAKASH.S	17-NOV-08	Tyco Electronics Dorcan, Swindon, SN3 5HH						
TOLERANCES UNLESS OTHERWISE SPECIFIED:	APVD	STEPHEN.P	17-NOV-08					NAME		
	0 PLC ±0.2	PRODUCT SPEC	-	PANEL POTENTIOMETERS						
1 PLC ±0.1	APPLICATION SPEC	-	SERIES 5930							
2 PLC ±-	WEIGHT	21g Approx.	SIZE	A 4	CAGE CODE	00779	DRAWING NO	©-1623755	RESTRICTED TO	-
3 PLC ±-										
4 PLC ±-										
ANGLES ±5°										
		CUSTOMER DRAWING		SCALE	2:1	SHEET	1 OF 1	REV	BA	