

DATA SHEET

TDA3615J Multiple voltage regulator

Product specification
Supersedes data of 1998 Jun 23

2004 Jan 12

Multiple voltage regulator

TDA3615J

FEATURES

General

- Six voltage regulators
- Five microprocessor controlled regulators (regulators 2 to 6)
- Regulator 1 and reset operate during load dump and thermal shutdown
- Low reverse current of regulator 1
- Very low quiescent current when regulators 2 to 6 and power switches are switched off ($V_{I(iq)} = 0\text{ V}$)
- Reset output
- Adjustable display regulator
- High ripple rejection
- Three power switches
- Low noise for regulators 2 to 6.

Protections

- Reverse polarity safe (down to -18 V without high reverse current)
- Able to withstand voltages up to 18 V at the output (supply line may be short-circuited)
- ESD protected on all pins
- Thermal protection
- Load dump protection
- Foldback current limit protection (except for regulator 2)
- The regulator outputs and the power switches are DC short-circuited safe to ground and V_{bat} .

GENERAL DESCRIPTION

The TDA3615J is a multiple output voltage regulator with power switches, intended for use in car radios with or without a microprocessor. It contains:

- One fixed voltage regulator (regulator 1) intended to supply a microprocessor, that also operates during load dump and thermal shutdown
- 5 power regulators supplied by $V_{I(iq)}$
- 3 power switches with protections
- 3 enable inputs for selecting regulators 2 to 6 and the three power switches
- Very low quiescent current of typical $110\text{ }\mu\text{A}$.

ORDERING INFORMATION

TYPE NUMBER	PACKAGE		
	NAME	DESCRIPTION	VERSION
TDA3615J	DBS17P	plastic DIL-bent-SIL power package; 17 leads (lead length 12 mm)	SOT243-1

Multiple voltage regulator

TDA3615J

QUICK REFERENCE DATA

SYMBOL	PARAMETER	CONDITIONS	MIN.	TYP.	MAX.	UNIT
Supply						
$V_{bat/I(iig)}$	supply voltage					
	operating	regulators on	11	14.4	18	V
	operating	regulator 1 on	3.5	14.4	18	V
	jump start	$t \leq 10$ minutes	–	–	30	V
	load dump protection	$t \leq 50$ ms; $t_r \geq 2.5$ ms	–	–	50	V
I_q	quiescent supply current	$V_{bat} = 14.4$ V; $V_{I(iig)} < 1$ V; note 1	–	110	250	μ A
		$V_{bat} = V_{I(iig)} = 14.4$ V; selector inputs 0,0,0 (state 3 in Table 1); note 1	–	125	–	μ A
Voltage regulators						
$V_{O(REG1)}$	output voltage regulator 1 (5 V standby)	$0.5 \text{ mA} \leq I_{REG1} \leq 50 \text{ mA}$	4.75	5.0	5.25	V
$V_{O(REG2)}$	output voltage regulator 2 (filament)	$0.5 \text{ mA} \leq I_{REG2} \leq 300 \text{ mA}$	2.7	2.85	3.0	V
$V_{O(REG3)}$	output voltage regulator 3 (5 V logic)	$0.5 \text{ mA} \leq I_{REG3} \leq 450 \text{ mA}$	4.75	5.0	5.25	V
$V_{O(REG4)}$	output voltage regulator 4 (synthesizer)	$0.5 \text{ mA} \leq I_{REG4} \leq 100 \text{ mA}$	9.0	9.5	10.0	V
$V_{O(REG5)}$	output voltage regulator 5 (AM)	$0.5 \text{ mA} \leq I_{REG5} \leq 150 \text{ mA}$	9.0	9.5	10.0	V
$V_{O(REG6)}$	output voltage regulator 6 (FM)	$0.5 \text{ mA} \leq I_{REG6} \leq 150 \text{ mA}$	9.0	9.5	10.0	V
Power switches						
$V_{drop(sw1)}$	drop-out voltage switch 1 (antenna)	$I_{SW1} = 0.55 \text{ A}$	0.1	0.45	1.6	V
$I_{M(sw1)}$	peak current switch 1	$t < 1 \text{ s}$	1.7	1.9	–	A
$V_{drop(sw2)}$	drop-out voltage switch 2 (media)	$I_{SW2} = 1 \text{ A}$	–	0.5	1.0	V
V_{clamp2}	clamping voltage switch 2		–	15.0	16	V
$V_{drop(sw3)}$	drop-out voltage switch 3 (display)	$I_{SW3} = 0.35 \text{ A}$	–	0.5	1.0	V
V_{clamp3}	clamping voltage switch 3		–	15.2	16	V

Note

1. The quiescent current is measured when $R_L = \infty$.

Multiple voltage regulator

TDA3615J

BLOCK DIAGRAM

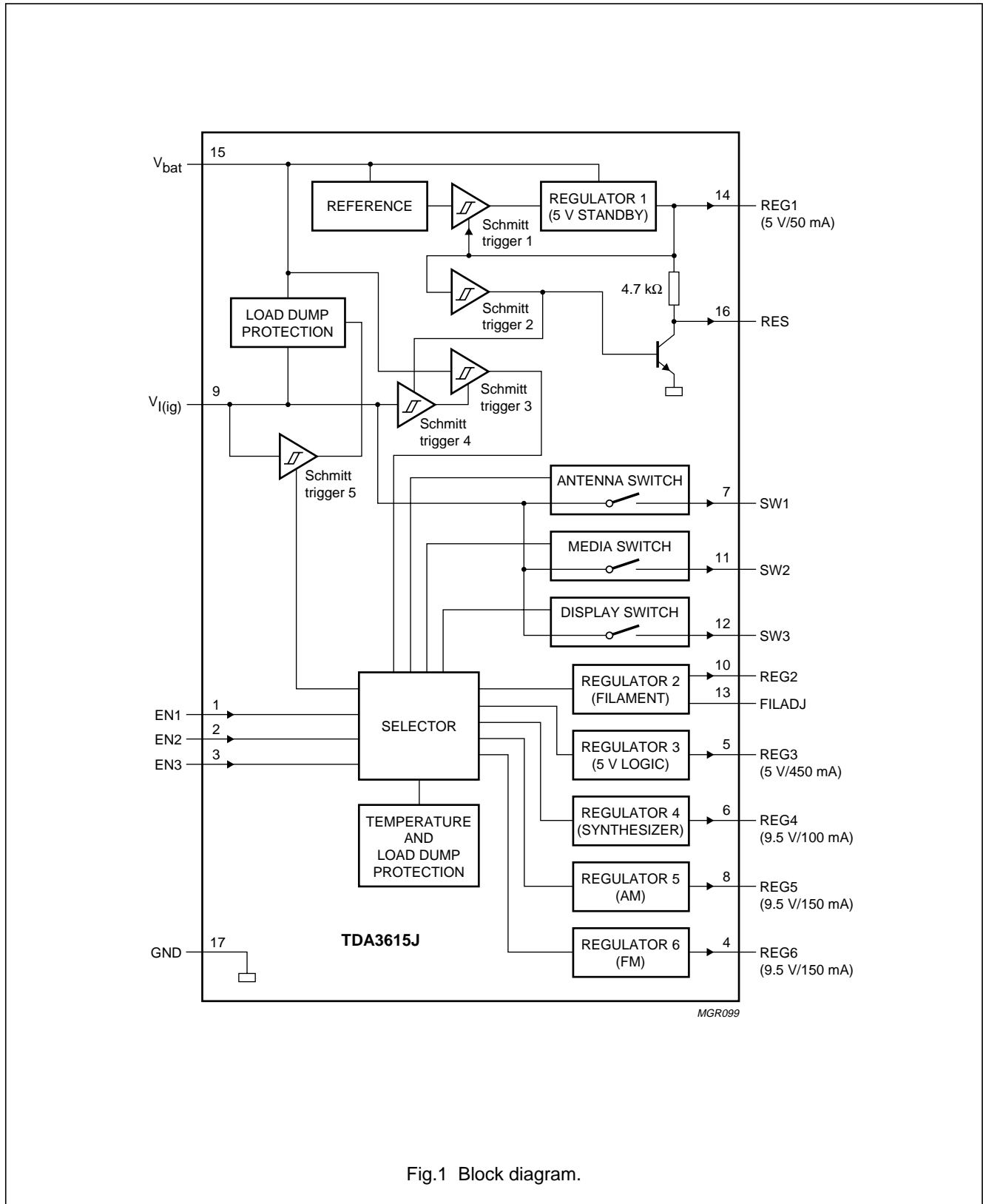

Fig.1 Block diagram.

Multiple voltage regulator

TDA3615J

PINNING

SYMBOL	PIN	DESCRIPTION
EN1	1	enable input 1
EN2	2	enable input 2
EN3	3	enable input 3
REG6	4	regulator 6 output, FM
REG3	5	regulator 3 output, 5 V logic
REG4	6	regulator 4 output, synthesizer
SW1	7	switch 1 output, antenna
REG5	8	regulator 5 output, AM
$V_{I(ig)}$	9	ignition input voltage
REG2	10	regulator 2 output, filament
SW2	11	switch 2 output, media
SW3	12	switch 3 output, display
FILADJ	13	filament adjustment
REG1	14	regulator 1 output, 5 V standby
V_{bat}	15	battery input voltage
RES	16	reset output
GND	17	ground

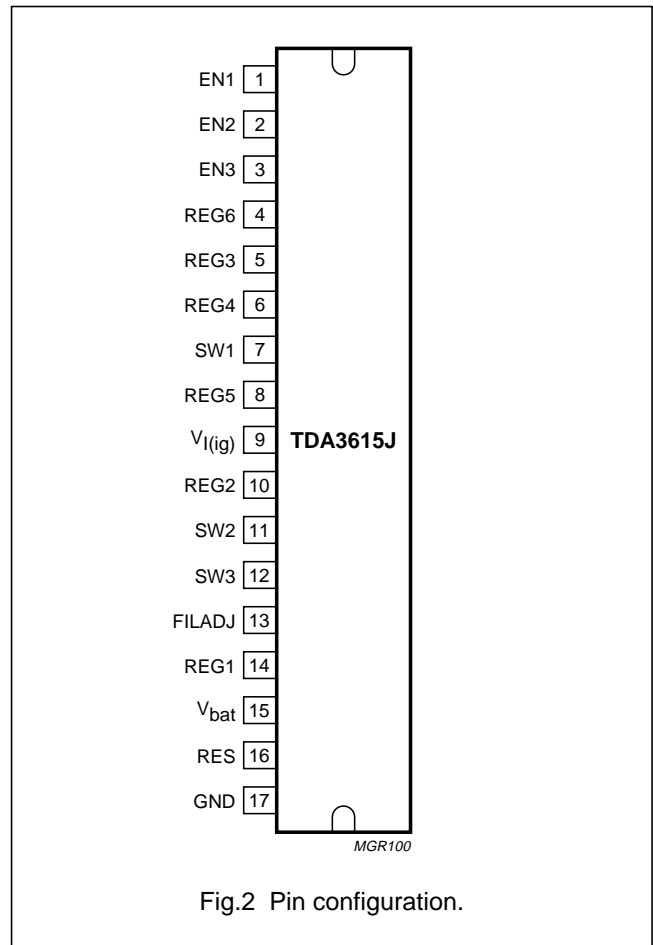

Fig.2 Pin configuration.

Multiple voltage regulator

TDA3615J

FUNCTIONAL DESCRIPTION

The TDA3615J is a multiple voltage regulator intended to supply a microprocessor (e.g. in car radio applications). Because of low-voltage operation of the application, a low-voltage drop regulator is used in the TDA3615J.

Regulator 1 (5 V standby) will switch on when the supply voltage exceeds 7.2 V for the first time and will switch off again when the output voltage of the regulator drops below 3.5 V.

Reset is used to indicate that the regulator output voltage is within its voltage range. This start-up feature is built-in to secure a smooth start-up of the microprocessor at first connection, without uncontrolled switching of the standby regulator during the start-up sequence.

All other regulators and switches can be switched on and off by using the three control input pins. This is only possible when both supply voltages (V_{bat} and $V_{I(ig)}$) are within their voltage range. Table 1 shows all possible states.

The filament regulator output voltage of the TDA3615J can be adjusted with pin FILADJ.

All output pins are fully protected. The regulators are protected against load dump and short-circuit (foldback current protection, except the filament regulator output). At load dump all regulator outputs will go LOW except the 5 V standby regulator output.

The antenna switch and the media switch can withstand 'loss of ground'. This means that the ground pin is disconnected and the switch output is connected to ground (V_{bat} and $V_{I(ig)}$ are normally connected to the right pin).

Selector settings

Table 1 Possible states of outputs depending on inputs

STATE	INPUTS					OUTPUTS								
	V_{bat}	$V_{I(ig)}$	EN1	EN2	EN3	REG1	REG2	REG3	REG4	REG5	REG6	SW1	SW2	SW3
1	0	X ⁽¹⁾	X ⁽¹⁾	X ⁽¹⁾	X ⁽¹⁾	0	0	0	0	0	0	0	0	0
2	1	0	X ⁽¹⁾	X ⁽¹⁾	X ⁽¹⁾	1	0	0	0	0	0	0	0	0
3	1	1	0	0	0	1	0	0	0	0	0	0	0	0
4	1	1	0	0	1	1	1	1	1	0	1	1	0	1
5	1	1	0	1	0	1	1	1	1	1	0	1	0	1
6	1	1	0	1	1	1	1	1	0	0	0	0	1	1
7	1	1	1	0	0	1	1	1	0	0	0	0	0	1
8	1	1	1	0	1	1	1	1	1	0	1	1	1	1
9	1	1	1	1	0	1	1	1	1	1	0	1	1	1
10	1	1	1	1	1	1	1	1	1	0	0	1	1	1

Note

1. X = don't care.

Multiple voltage regulator

TDA3615J

LIMITING VALUES

In accordance with the Absolute Maximum Rating System (IEC 60134).

SYMBOL	PARAMETER	CONDITIONS	MIN.	MAX.	UNIT
$V_{bat/I(iig)}$	supply voltage	regulators on	–	18	V
	operating	$t \leq 10$ minutes	–	30	V
	jump start	$t \leq 50$ ms; $t_r \geq 2.5$ ms	–	50	V
V_{rp}	reverse polarity voltage	non-operating	–	–18	V
P_{tot}	total power dissipation	$T_{amb} = 25$ °C	–	62.5	W
T_{stg}	storage temperature	non-operating	–55	+150	°C
T_{amb}	ambient temperature	operating	–40	+85	°C
T_j	junction temperature	operating	–40	+150	°C

THERMAL CHARACTERISTICS

SYMBOL	PARAMETER	CONDITIONS	VALUE	UNIT
$R_{th(j-c)}$	thermal resistance from junction to case		2	K/W
$R_{th(j-a)}$	thermal resistance from junction to ambient	in free air	40	K/W

QUALITY SPECIFICATION

Quality specification is in accordance with "SNW-FQ-611".

CHARACTERISTICS

$V_{bat} = V_{I(iig)} = 14.4$ V; $T_{amb} = 25$ °C; see Fig.4; unless otherwise specified.

SYMBOL	PARAMETER	CONDITIONS	MIN.	TYP.	MAX.	UNIT
Supply						
$V_{bat/I(iig)}$	supply voltage	regulators on	11	14.4	18	V
	operating	$t \leq 10$ minutes	–	–	30	V
	jump start	$t \leq 50$ ms; $t_r \geq 2.5$ ms	–	–	50	V
I_q	quiescent supply current	$V_{bat} = 14.4$ V; $V_{I(iig)} < 1$ V; note 1	–	110	250	µA
		$V_{bat} = V_{I(iig)} = 14.4$ V; selector inputs 0,0,0; note 1	–	125	–	µA
Reset buffer						
$I_{sink(L)}$	LOW-level sink current		2	15	–	mA
$R_{pu(int)}$	internal pull-up resistance		3.7	4.7	5.7	kΩ
Selector control inputs						
V_{IL}	LOW-level input voltage		–0.5	–	+0.8	V
V_{IH}	HIGH-level input voltage		2.0	–	–	V
I_{IH}	HIGH-level input current	$V_{IH} > 2$ V	–	–	1.0	mA
I_{IL}	LOW-level input current	$V_{IL} < 0.8$ V	–1.0	–	–	mA

Multiple voltage regulator

TDA3615J

SYMBOL	PARAMETER	CONDITIONS	MIN.	TYP.	MAX.	UNIT
Regulator 1 for 5 V standby ($I_{REG1} = 1 \text{ mA}$ unless otherwise specified)						
$V_{O(REG1)}$	output voltage	$0.5 \text{ mA} \leq I_{REG1} \leq 50 \text{ mA}$	4.75	5.0	5.25	V
		$6.5 \text{ V} \leq V_{bat} \leq 18 \text{ V}$; note 2	4.75	5.0	5.25	V
		$18 \text{ V} \leq V_{bat} \leq 50 \text{ V}$; load dump; $I_{REG1} = 30 \text{ mA}$	4.75	5.0	5.25	V
ΔV_{LN1}	line voltage regulation	$7 \text{ V} \leq V_{bat} \leq 18 \text{ V}$	–	3	50	mV
ΔV_{L1}	load voltage regulation	$0.5 \text{ mA} \leq I_{REG1} \leq 50 \text{ mA}$	–	–	60	mV
SVRR1	supply voltage ripple rejection	$f_i = 120 \text{ Hz}$; $V_{i(p-p)} = 2 \text{ V}$	60	72	–	dB
V_{drop1}	drop-out voltage	$V_{bat} = 5 \text{ V}$; note 3	–	0.27	1	V
I_{I1}	current limit	$V_{REG1} > 4.5 \text{ V}$	60	170	–	mA
I_{sc1}	short-circuit current	$R_L \leq 0.5 \Omega$; note 4	15	60	–	mA
Regulator 2 for filament ($I_{REG2} = 5 \text{ mA}$ unless otherwise specified)						
$V_{O(REG2)}$	output voltage	$0.5 \text{ mA} \leq I_{REG2} \leq 300 \text{ mA}$	2.7	2.85	3.0	V
		$7.5 \text{ V} \leq V_{bat} \leq 16.9 \text{ V}$	2.7	2.85	3.0	V
		adjust control	1.1	adjust	$V_{I(ig)}$	V
ΔV_{LN2}	line voltage regulation	$7.5 \text{ V} \leq V_{bat} \leq 16.9 \text{ V}$	–	–	50	mV
ΔV_{L2}	load voltage regulation	$5 \text{ mA} \leq I_{REG2} \leq 300 \text{ mA}$	–	–	70	mV
SVRR2	supply voltage ripple rejection	$f_i = 120 \text{ Hz}$; $V_{i(p-p)} = 2 \text{ V}$	60	80	–	dB
I_{sc2}	short-circuit current	$R_L \leq 0.5 \Omega$	0.35	0.66	–	A
Regulator 3 for 5 V logic ($I_{REG3} = 5 \text{ mA}$ unless otherwise specified)						
$V_{O(REG3)}$	output voltage	$0.5 \text{ mA} \leq I_{REG3} \leq 450 \text{ mA}$	4.75	5.0	5.25	V
		$7.5 \text{ V} \leq V_{bat} \leq 16.9 \text{ V}$	4.75	5.0	5.25	V
ΔV_{LN3}	line voltage regulation	$7.5 \text{ V} \leq V_{bat} \leq 16.9 \text{ V}$	–	–	50	mV
ΔV_{L3}	load voltage regulation	$5 \text{ mA} \leq I_{REG3} \leq 450 \text{ mA}$	–	–	60	mV
SVRR3	supply voltage ripple rejection	$f_i = 120 \text{ Hz}$; $V_{i(p-p)} = 2 \text{ V}$	60	80	–	dB
I_{I3}	current limit	$V_{REG3} > 3.5 \text{ V}$	0.5	0.85	–	A
I_{sc3}	short-circuit current	$R_L \leq 0.5 \Omega$; note 4	20	125	–	mA
Regulator 4 for synthesizer ($I_{REG4} = 5 \text{ mA}$ unless otherwise specified)						
$V_{O(REG4)}$	output voltage	$0.5 \text{ mA} \leq I_{REG4} \leq 100 \text{ mA}$	9.0	9.5	10.0	V
		$10.75 \text{ V} \leq V_{bat} \leq 16.9 \text{ V}$	9.0	9.5	10.0	V
ΔV_{LN4}	line voltage regulation	$10.75 \text{ V} \leq V_{bat} \leq 16.9 \text{ V}$	–	–	50	mV
ΔV_{L4}	load voltage regulation	$5 \text{ mA} \leq I_{REG4} \leq 100 \text{ mA}$	–	–	70	mV
SVRR4	supply voltage ripple rejection	$f_i = 120 \text{ Hz}$; $V_{i(p-p)} = 2 \text{ V}$	60	70	–	dB
V_{drop4}	drop-out voltage	$I_{REG4} = 0.1 \text{ A}$; $V_{bat} = 9 \text{ V}$; note 5	–	0.18	0.5	V
I_{I4}	current limit	$V_{REG4} > 7 \text{ V}$	0.35	0.57	–	A
I_{sc4}	short-circuit current	$R_L \leq 0.5 \Omega$; note 4	20	160	–	mA

Multiple voltage regulator

TDA3615J

SYMBOL	PARAMETER	CONDITIONS	MIN.	TYP.	MAX.	UNIT
Regulator 5 for AM ($I_{REG5} = 5 \text{ mA}$ unless otherwise specified)						
$V_{O(REG5)}$	output voltage	$0.5 \text{ mA} \leq I_{REG5} \leq 150 \text{ mA}$	9.0	9.5	10.0	V
		$10.75 \text{ V} \leq V_{bat} \leq 16.9 \text{ V}$	9.0	9.5	10.0	V
ΔV_{LN5}	line voltage regulation	$10.75 \text{ V} \leq V_{bat} \leq 16.9 \text{ V}$	–	–	50	mV
ΔV_{L5}	load voltage regulation	$5 \text{ mA} \leq I_{REG5} \leq 150 \text{ mA}$	–	–	70	mV
SVRR5	supply voltage ripple rejection	$f_i = 120 \text{ Hz}$; $V_{i(p-p)} = 2 \text{ V}$	60	70	–	dB
V_{drop5}	drop-out voltage	$I_{REG5} = 0.15 \text{ A}$; $V_{bat} = 9 \text{ V}$; note 5	–	0.35	1	V
I_{l5}	current limit	$V_{REG5} > 7 \text{ V}$	0.2	0.37	–	A
I_{sc5}	short-circuit current	$R_L \leq 0.5 \Omega$; note 4	50	130	–	mA
Regulator 6 for FM ($I_{REG6} = 5 \text{ mA}$ unless otherwise specified)						
$V_{O(REG6)}$	output voltage	$0.5 \text{ mA} \leq I_{REG6} \leq 150 \text{ mA}$	9.0	9.5	10.0	V
		$10.75 \text{ V} \leq V_{bat} \leq 16.9 \text{ V}$	9.0	9.5	10.0	V
ΔV_{LN6}	line voltage regulation	$10.75 \text{ V} \leq V_{bat} \leq 16.9 \text{ V}$	–	–	50	mV
ΔV_{L6}	load voltage regulation	$5 \text{ mA} \leq I_{REG6} \leq 150 \text{ mA}$	–	–	70	mV
SVRR6	supply voltage ripple rejection	$f_i = 120 \text{ Hz}$; $V_{i(p-p)} = 2 \text{ V}$	60	70	–	dB
V_{drop6}	drop-out voltage	$I_{REG6} = 0.15 \text{ A}$; $V_{bat} = 9 \text{ V}$; note 5	–	0.4	1	V
I_{l6}	current limit	$V_{REG6} > 7 \text{ V}$	0.2	0.37	–	A
I_{sc6}	short-circuit current	$R_L \leq 0.5 \Omega$; note 4	50	125	–	mA
Power switch 1 (antenna)						
$V_{drop(sw1)}$	drop-out voltage	$I_{SW1} = 0.55 \text{ A}$; note 5	0.1	0.45	1.6	V
V_{clamp1}	clamping voltage		–	15.2	16	V
I_{M1}	peak current	$t < 1 \text{ s}$	1.7	1.9	–	A
Power switch 2 (media)						
$V_{drop(sw2)}$	drop-out voltage	$I_{SW2} = 1 \text{ A}$; note 5	–	0.5	1.0	V
V_{clamp2}	clamping voltage		–	15.0	16	V
Power switch 3 (display)						
$V_{drop(sw3)}$	drop-out voltage	$I_{SW3} = 0.35 \text{ A}$; note 5	–	0.5	1.0	V
V_{clamp3}	clamping voltage		–	15.2	16	V
Schmitt trigger 1 for regulator						
V_{thr1}	rising threshold voltage	selector inputs 0,0,0 (state 3 in Table 1); $I_{REG1} = 10 \text{ mA}$	6.2	7.2	7.8	V
V_{thf1}	falling threshold voltage	selector inputs 0,0,0 (state 3 in Table 1); $I_{REG1} = 10 \text{ mA}$	3.2	3.5	3.7	V
V_{hys1}	hysteresis voltage		–	3.7	–	V
Schmitt trigger 2 for reset; note 6						
V_{thr2}	rising threshold voltage	$I_{REG1} = 10 \text{ mA}$	4.28	4.45	4.73	V
V_{thf2}	falling threshold voltage	$I_{REG1} = 10 \text{ mA}$	4.2	4.35	4.5	V
V_{hys2}	hysteresis voltage		–	0.1	–	V

Multiple voltage regulator

TDA3615J

SYMBOL	PARAMETER	CONDITIONS	MIN.	TYP.	MAX.	UNIT
Schmitt trigger 3 for battery sense						
V_{thr3}	rising threshold voltage	$V_{I(i\text{g})} = 14.4 \text{ V}; R_L = 1 \text{ k}\Omega$	6.8	7.35	7.9	V
V_{thf3}	falling threshold voltage	$V_{I(i\text{g})} = 14.4 \text{ V}; R_L = 1 \text{ k}\Omega$	5.5	5.95	6.4	V
V_{hys3}	hysteresis voltage		–	1.4	–	V
Schmitt trigger 4 for ignition sense						
V_{thr4}	rising threshold voltage	$V_{bat} = 14.4 \text{ V}; R_L = 100 \Omega$	7.2	7.6	8.0	V
V_{thf4}	falling threshold voltage	$V_{bat} = 14.4 \text{ V}; R_L = 100 \Omega$	6.0	6.3	6.8	V
V_{hys4}	hysteresis voltage		–	1.3	–	V
Schmitt trigger 5 for load dump						
V_{thr5}	rising threshold voltage	selector inputs 1,0,1 (state 8 in Table 1); note 7	17.5	18.5	19.5	V
V_{thf5}	falling threshold voltage	selector inputs 1,0,1 (state 8 in Table 1); note 7	17	$V_{thr} - 0.3$	$V_{thr} - 0.1$	V

Notes

1. The quiescent current is measured when $R_L = \infty$.
2. Only if V_{bat} has exceeded 7.2 V.
3. The drop-out voltage of regulator 1 is measured between V_{bat} and V_{REGx} .
4. The foldback current protection limits the dissipation power at short-circuit.
5. The drop-out voltage of regulators 2 to 6 and power switches 1, 2 and 3 are measured between $V_{I(i\text{g})}$ and V_{REGx} or between $V_{I(i\text{g})}$ and V_{SWx} .
6. The voltage of regulator 1 sinks as a result of a supply voltage drop.
7. Only when one of the control pins is HIGH.

Multiple voltage regulator

TDA3615J

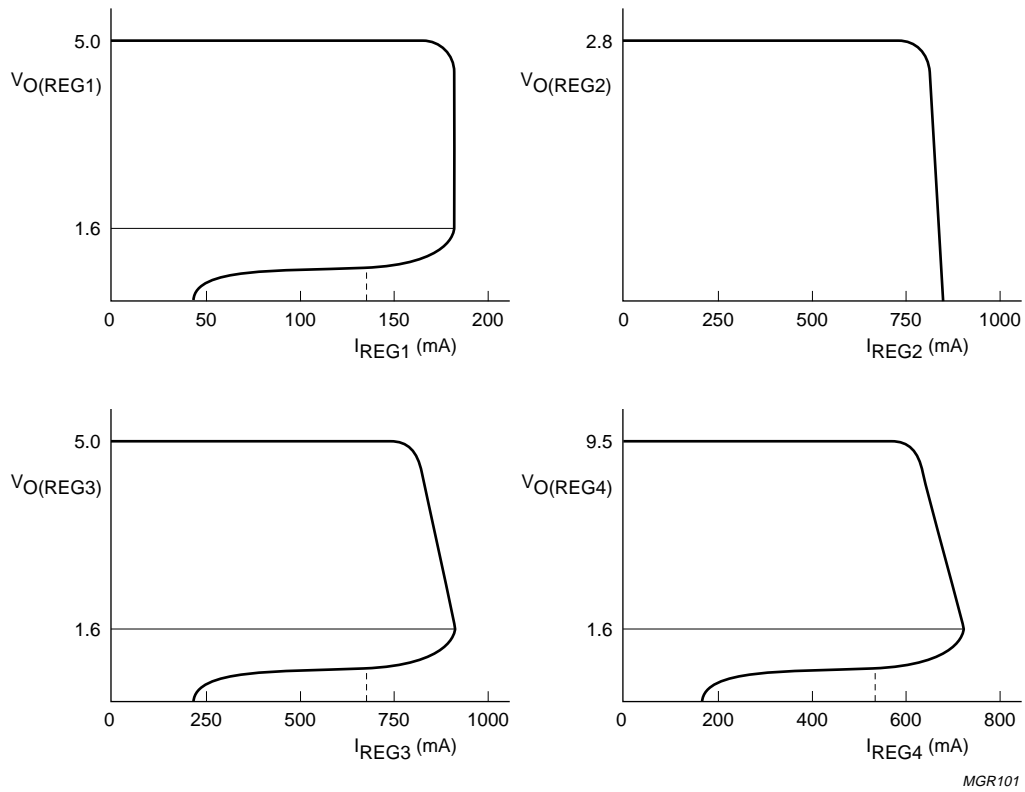

Fig.3 Typical foldback current protection behaviour.

Multiple voltage regulator

TDA3615J

TEST AND APPLICATION INFORMATION

Test information

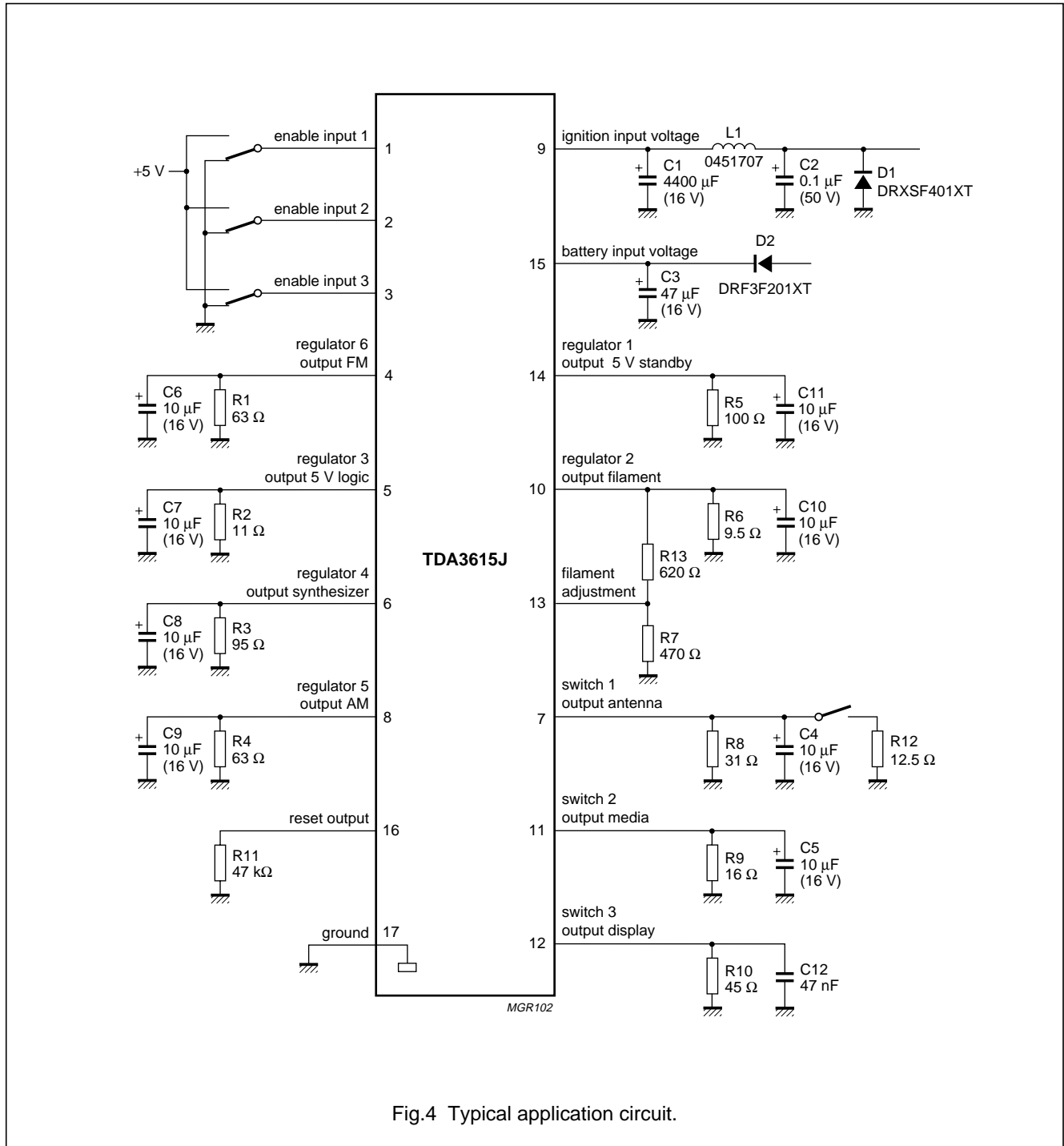

Fig.4 Typical application circuit.

Multiple voltage regulator

TDA3615J

Application information

NOISE

Table 2 Noise figures

REGULATOR	NOISE FIGURE (μV) ⁽¹⁾		
	$C_o = 10 \mu\text{F}$	$C_o = 47 \mu\text{F}$	$C_o = 100 \mu\text{F}$
1	175	145	100
2	125	98	85
3	180	150	125
4	290	260	190
5	290	260	190
6	290	260	190

Note

1. Measured at a bandwidth of 1 MHz.

The regulator outputs for regulators 2 to 6 are designed in such a way that the noise is very low and the stability is very good. The noise output voltages are depending on the output capacitors. Table 2 describes the influence of the output capacitors on the output noise.

STABILITY

The regulators are made stable with the external connected output capacitors.

With almost any output capacitor, stability can be guaranteed; see Figs 5, 6 and 7.

When only an electrolytic capacitor is used, the temperature behaviour of this output capacitor can cause oscillations at extreme low temperature. The next 2 examples show how an output capacitor value is selected. Oscillation problems can be avoided by adding a 47 nF capacitor in parallel with the electrolytic capacitor.

Example 1 (regulator 1)

Regulator 1 is made stable with an electrolytic output capacitor of 10 μF (ESR = 3.1 Ω). At -30°C the capacitor value is decreased to 3 μF and the ESR is increased to 22 Ω . The regulator will remain stable at -30°C ; see Fig.5.

Example 2 (regulator 5)

Regulator 5 is made stable with a 2.2 μF electrolytic capacitor (ESR = 8 Ω). At -30°C the capacitor value is decreased to 0.8 μF and the ESR is increased to 56 Ω . Using Fig.6, the regulator will be instable at -30°C .

Even when only a small MKT capacitor of 47 nF is used as output capacitor, regulator 5 will remain stable over all temperatures.

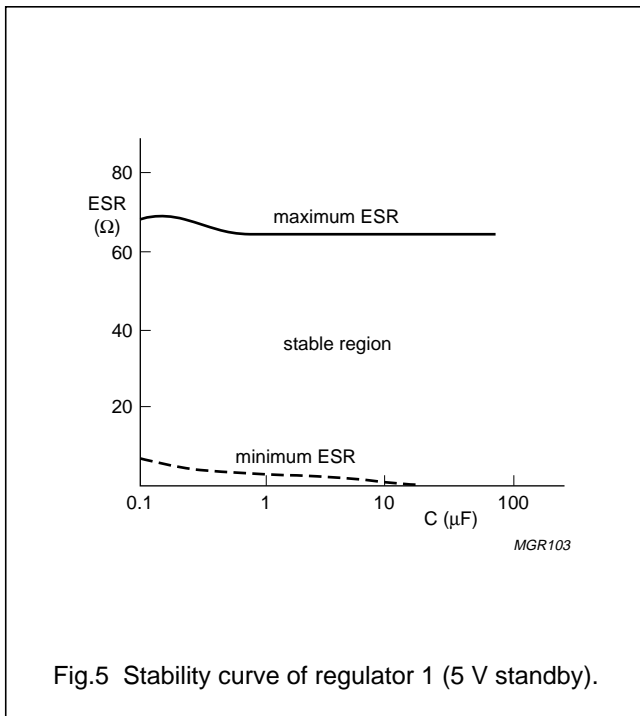

Fig.5 Stability curve of regulator 1 (5 V standby).

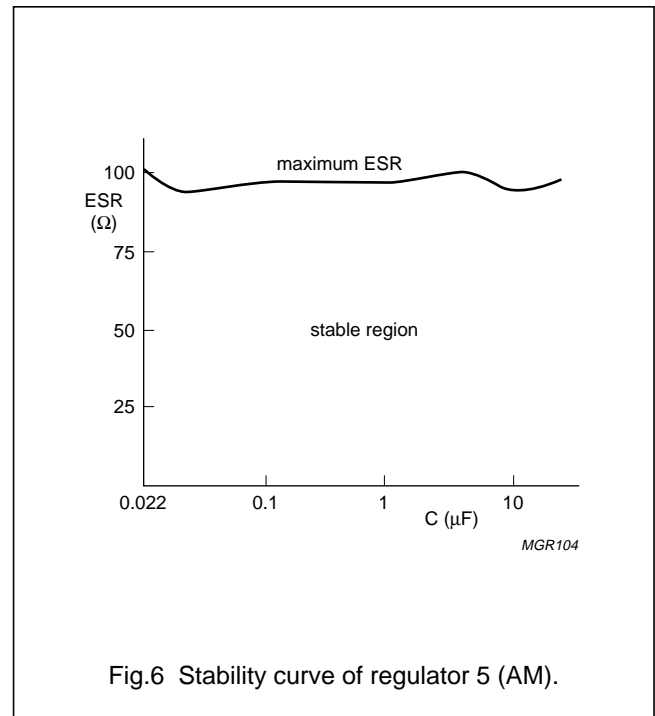

Fig.6 Stability curve of regulator 5 (AM).

Multiple voltage regulator

TDA3615J

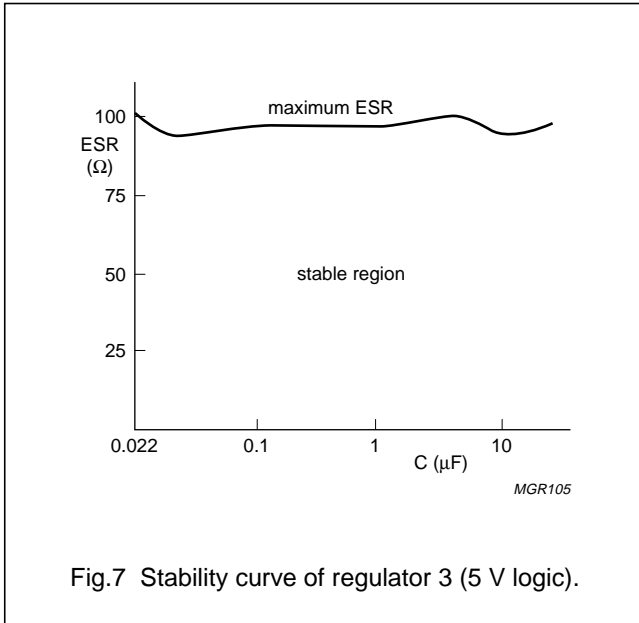

Fig.7 Stability curve of regulator 3 (5 V logic).

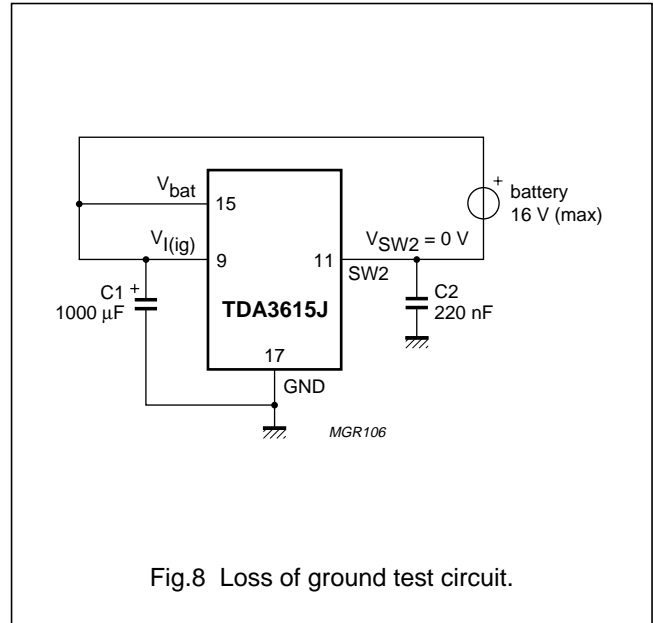

Fig.8 Loss of ground test circuit.

LOSS OF GROUND PROTECTION

Two power switches (media and antenna) are protected for loss of ground. The loss of ground situation is depicted in Fig.8. The ground terminal of the battery is connected to the output of the media switch. Two problems occur:

1. At first connection a high charge current will flow through C1 to the ground terminal (pin 17) of the TDA3615J and out of the switch output (pin 11). The media and antenna switches are protected to limit this current.
2. When the switch is enabled, a short-circuit current will flow out of the power switch output (pin 11) because the output of the switch is shortened below substrate potential.

A special protection is built-in to avoid the media and antenna switches from being damaged during a loss of ground condition.

In practice, this condition can occur when the ground terminal of the total application is connected to the switch output due to a bad wiring.

CAPACITIVE LOADS ON POWER SWITCHES

Power switches can deliver a large current to the connected loads. When a supply voltage ripple is applied, large load currents will flow when capacitive loads are used in parallel with normal loads.

When the output of a power switch is forced above $V_{I(ig)}$ an internal protection is activated to switch off the switch as long as the fault is present.

The display switch in particular is sensitive to capacitive loads.

We therefore strongly advise:

- Use only a 47 nF output capacitor on the display switch
- Use a 10 μF capacitor on the outputs of the antenna and media switch.

On the outputs of regulators 2 to 6 a capacitor of 47 nF can be used; larger values are possible but not necessary to guarantee stability; see Figs 4, 6 and 7.

Multiple voltage regulator

TDA3615J

PACKAGE OUTLINE

DBS17P: plastic DIL-bent-SIL power package; 17 leads (lead length 7.7 mm)

SOT243-3

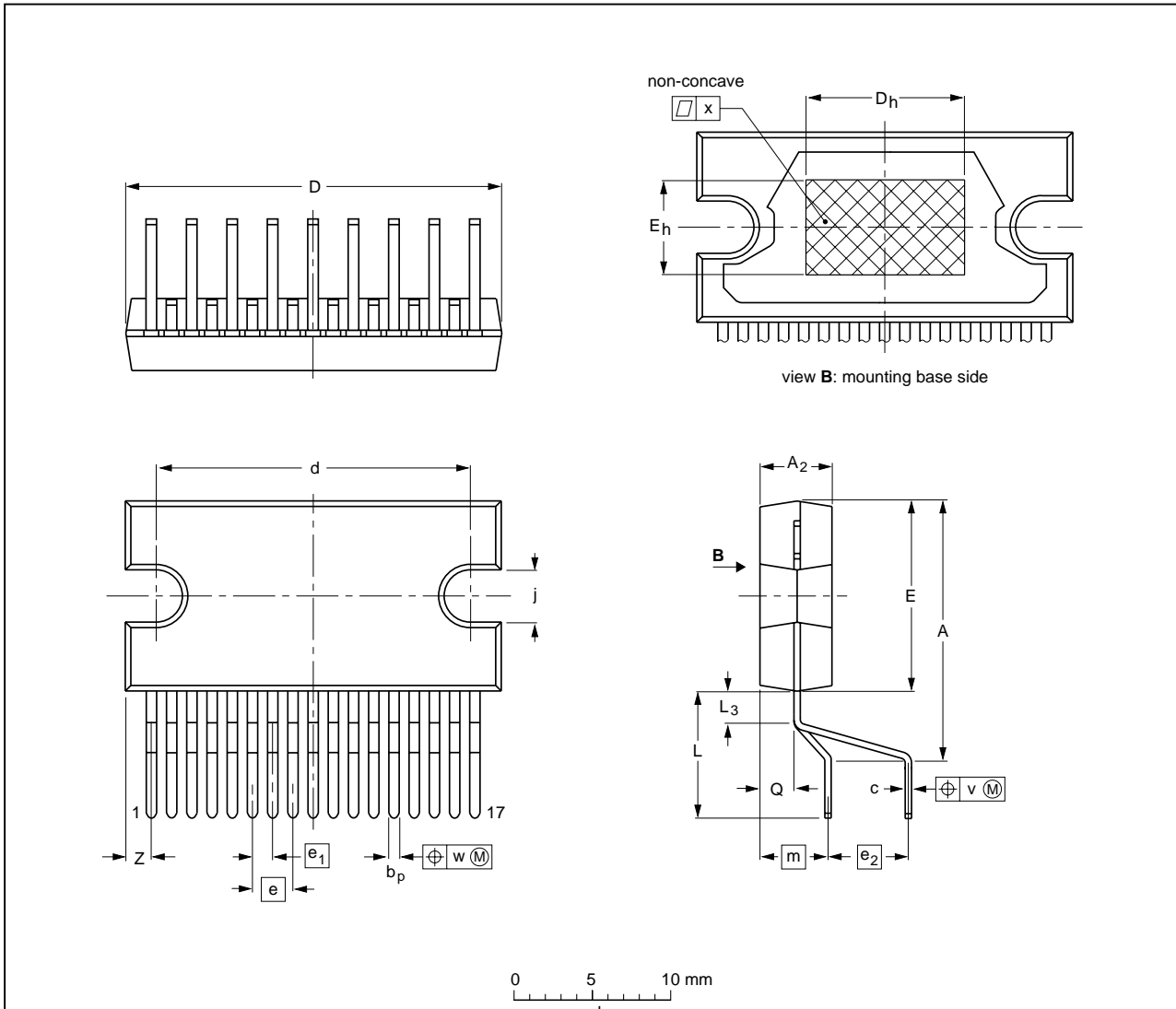

DIMENSIONS (mm are the original dimensions)

UNIT	A	A ₂	b _p	c	D ⁽¹⁾	d	D _h	E ⁽¹⁾	e	e ₁	e ₂	E _h	j	L	L ₃	m	Q	v	w	x	z ⁽¹⁾
mm	17.0 15.5	4.6 4.4	0.75 0.60	0.48 0.38	24.0 23.6	20.0 19.6	10	12.2 11.8	2.54	1.27	5.08	6	3.4 3.1	8.4 7.0	2.4 1.6	4.3	2.1 1.8	0.6	0.25	0.03	2.00 1.45

Note

1. Plastic or metal protrusions of 0.25 mm maximum per side are not included.

OUTLINE VERSION	REFERENCES			EUROPEAN PROJECTION	ISSUE DATE
	IEC	JEDEC	JEITA		
SOT243-3					99-12-17 03-03-12

Multiple voltage regulator

TDA3615J

SOLDERING**Introduction to soldering through-hole mount packages**

This text gives a brief insight to wave, dip and manual soldering. A more in-depth account of soldering ICs can be found in our *"Data Handbook IC26; Integrated Circuit Packages"* (document order number 9398 652 90011).

Wave soldering is the preferred method for mounting of through-hole mount IC packages on a printed-circuit board.

Soldering by dipping or by solder wave

Driven by legislation and environmental forces the worldwide use of lead-free solder pastes is increasing. Typical dwell time of the leads in the wave ranges from 3 to 4 seconds at 250 °C or 265 °C, depending on solder material applied, SnPb or Pb-free respectively.

The total contact time of successive solder waves must not exceed 5 seconds.

The device may be mounted up to the seating plane, but the temperature of the plastic body must not exceed the specified maximum storage temperature ($T_{stg(max)}$). If the printed-circuit board has been pre-heated, forced cooling may be necessary immediately after soldering to keep the temperature within the permissible limit.

Manual soldering

Apply the soldering iron (24 V or less) to the lead(s) of the package, either below the seating plane or not more than 2 mm above it. If the temperature of the soldering iron bit is less than 300 °C it may remain in contact for up to 10 seconds. If the bit temperature is between 300 and 400 °C, contact may be up to 5 seconds.

Suitability of through-hole mount IC packages for dipping and wave soldering methods

PACKAGE	SOLDERING METHOD	
	DIPPING	WAVE
CPGA, HCPGA	–	suitable
DBS, DIP, HDIP, RDBS, SDIP, SIL	suitable	suitable ⁽¹⁾
PMFP ⁽²⁾	–	not suitable

Notes

1. For SDIP packages, the longitudinal axis must be parallel to the transport direction of the printed-circuit board.
2. For PMFP packages hot bar soldering or manual soldering is suitable.

Multiple voltage regulator

TDA3615J

DATA SHEET STATUS

LEVEL	DATA SHEET STATUS ⁽¹⁾	PRODUCT STATUS ⁽²⁾⁽³⁾	DEFINITION
I	Objective data	Development	This data sheet contains data from the objective specification for product development. Philips Semiconductors reserves the right to change the specification in any manner without notice.
II	Preliminary data	Qualification	This data sheet contains data from the preliminary specification. Supplementary data will be published at a later date. Philips Semiconductors reserves the right to change the specification without notice, in order to improve the design and supply the best possible product.
III	Product data	Production	This data sheet contains data from the product specification. Philips Semiconductors reserves the right to make changes at any time in order to improve the design, manufacturing and supply. Relevant changes will be communicated via a Customer Product/Process Change Notification (CPCN).

Notes

1. Please consult the most recently issued data sheet before initiating or completing a design.
2. The product status of the device(s) described in this data sheet may have changed since this data sheet was published. The latest information is available on the Internet at URL <http://www.semiconductors.philips.com>.
3. For data sheets describing multiple type numbers, the highest-level product status determines the data sheet status.

DEFINITIONS

Short-form specification — The data in a short-form specification is extracted from a full data sheet with the same type number and title. For detailed information see the relevant data sheet or data handbook.

Limiting values definition — Limiting values given are in accordance with the Absolute Maximum Rating System (IEC 60134). Stress above one or more of the limiting values may cause permanent damage to the device. These are stress ratings only and operation of the device at these or at any other conditions above those given in the Characteristics sections of the specification is not implied. Exposure to limiting values for extended periods may affect device reliability.

Application information — Applications that are described herein for any of these products are for illustrative purposes only. Philips Semiconductors make no representation or warranty that such applications will be suitable for the specified use without further testing or modification.

DISCLAIMERS

Life support applications — These products are not designed for use in life support appliances, devices, or systems where malfunction of these products can reasonably be expected to result in personal injury. Philips Semiconductors customers using or selling these products for use in such applications do so at their own risk and agree to fully indemnify Philips Semiconductors for any damages resulting from such application.

Right to make changes — Philips Semiconductors reserves the right to make changes in the products - including circuits, standard cells, and/or software - described or contained herein in order to improve design and/or performance. When the product is in full production (status 'Production'), relevant changes will be communicated via a Customer Product/Process Change Notification (CPCN). Philips Semiconductors assumes no responsibility or liability for the use of any of these products, conveys no licence or title under any patent, copyright, or mask work right to these products, and makes no representations or warranties that these products are free from patent, copyright, or mask work right infringement, unless otherwise specified.

Philips Semiconductors – a worldwide company

Contact information

For additional information please visit <http://www.semiconductors.philips.com>. Fax: +31 40 27 24825

For sales offices addresses send e-mail to: sales.addresses@www.semiconductors.philips.com.

© Koninklijke Philips Electronics N.V. 2004

SCA76

All rights are reserved. Reproduction in whole or in part is prohibited without the prior written consent of the copyright owner.

The information presented in this document does not form part of any quotation or contract, is believed to be accurate and reliable and may be changed without notice. No liability will be accepted by the publisher for any consequence of its use. Publication thereof does not convey nor imply any license under patent- or other industrial or intellectual property rights.

Printed in The Netherlands

R32/02/pp18

Date of release: 2004 Jan 12

Document order number: 9397 750 12584

Let's make things better.

**Philips
Semiconductors**



PHILIPS