

HEDS-9710

200 lpi Analog Output

Small Optical Encoder Modules



Data Sheet

HEDS-9710, HEDS-9711



Description

The HEDS-9710/HEDS-9711 series is a high performance, low cost, optical incremental encoder module. When operated in conjunction with either a codewheel or codestrip, this module detects rotary or linear position. The encoder module consists of a lensed LED source and a detector IC enclosed in a small C-shaped plastic package. Due to a highly collimated light source and a unique photodetector array, the module is extremely tolerant to mounting misalignment.

The two-channel analog outputs and 5 V supply input are accessed through four solder-plated leads located on 2.54 mm (0.1 inch) centers.

The standard HEDS-9710/HEDS-9711 is designed for use with an appropriate optical radius codewheel, or linear codestrip. Please contact the factory for more information.

Applications

The HEDS-9710/HEDS-9711 provides sophisticated motion detection at a low cost, making closed-loop control very cost-effective. Typical applications include printers, plotters, copiers, and office automation equipment.

Note: Avago Technologies encoders are not recommended for use in safety critical applications, eg., ABS braking systems, power steering, life support systems, and critical care medical equipment. Please contact sales representative if more clarification is needed.

Features

- Small size
- Multiple mounting options
- 200 lpi resolution
- Linear and rotary options available
- Insensitive to radial and axial play
- 15°C to 45°C operating temperature
- Two-channel analog output
- Single 5 V supply
- Wave solderable

ESD WARNING: NORMAL PRECAUTIONS SHOULD BE TAKEN TO AVOID STATIC DISCHARGE.

Theory of Operation

The HEDS-9710/HEDS-9711 is a C-shaped emitter/detector module. Coupled with a codewheel, it translates rotary motion into a two-channel analog output. Coupled with a codestrip, it translates linear motion into analog outputs.

The module contains a single Light Emitting Diode (LED) as its light source. The light is collimated into a parallel beam by means of a single lens located directly over the LED. Opposite the emitter is the integrated detector circuit. This IC consists of multiple sets of photodetectors and the signal processing circuitry necessary to produce the analog waveforms.

The codewheel/codestrip moves between the emitter and detector, causing the light beam to be interrupted by the pattern of spaces and bars on the codewheel/codestrip. The photodiodes which detect these interruptions are arranged in a pattern that corresponds to the radius and count density of the codewheel/codestrip. These detectors are also spaced such that a light period on one pair of detectors corresponds to a dark period on the adjacent pair of detectors.

The photodiode outputs are fed through the signal processing circuitry, which produces the final outputs for channels A and B. Due to this integrated phasing technique, the analog output of channel A is in quadrature with channel B (90 degrees out of phase).

Package Dimensions

See HEDS-9700 datasheet for package outline drawings.

Definitions

Count (N): The number of bar and window pairs or Counts Per Revolution (CPR) of the codewheel, or the number of Lines Per Inch (LPI) of the codestrip.

$$1 \text{ Shaft Rotation} = 360 \text{ mechanical degrees} \\ = N \text{ cycles}$$

$$1 \text{ cycle (c)} = 360 \text{ electrical degrees (°e)} \\ = 1 \text{ bar and window pair}$$

Pulse Width (P): The number of electrical degrees that an output is high during one cycle. This value is nominally 180°e or 1/2 cycle.

Pulse Width Error (ΔP): The deviation, in electrical degrees, of the pulse width from its ideal value of 180°e.

State Width (S): The number of electrical degrees between a transition in the output of channel A and the neighboring transition in the output of channel B. There are four states per cycle, each nominally 90°e.

State Width Error (ΔS): The deviation, in electrical degrees, of each state width from its ideal value of 90°e.

Phase (Φ): The number of electrical degrees between the center of the high state of channel A and the center of the high state of channel B. This value is nominally 90°e for quadrature output.

Phase Error (ΔΦ): The deviation of the phase from its ideal value of 90°e.

Direction of Rotation: When the codewheel rotates counter-clockwise, as viewed looking down on the module (so the marking is visible), channel A will lead channel B. If the codewheel rotates in the opposite direction, channel B will lead channel A.

Optical Radius (R_{OP}): The distance from the codewheel's center of rotation to the optical center (O.C.) of the encoder module.

Mounting Position (R_M): Distance from Motor Shaft center of rotation to center of Alignment Tab receiving hole.

Absolute Maximum Ratings

Parameter	Symbol	Min.	Max.	Units	Notes
Storage Temperature	T _S	-40	85	°C	
Operating Temperature	T _A	15	45	°C	
Supply Voltage	V _{CC}	-0.5	7	V	
Soldering Temperature			260	°C	t ≤ 5 sec.

Recommended Operating Conditions

Parameter	Symbol	Min.	Max.	Units	Notes
Temperature	T	15	45		
Supply Voltage	V _{CC}	4.8	5.2	V	Ripple < 100 mV _{p-p}
Count Frequency			8	kHz	(Velocity (rpm) x N) 60

Waveform Definition

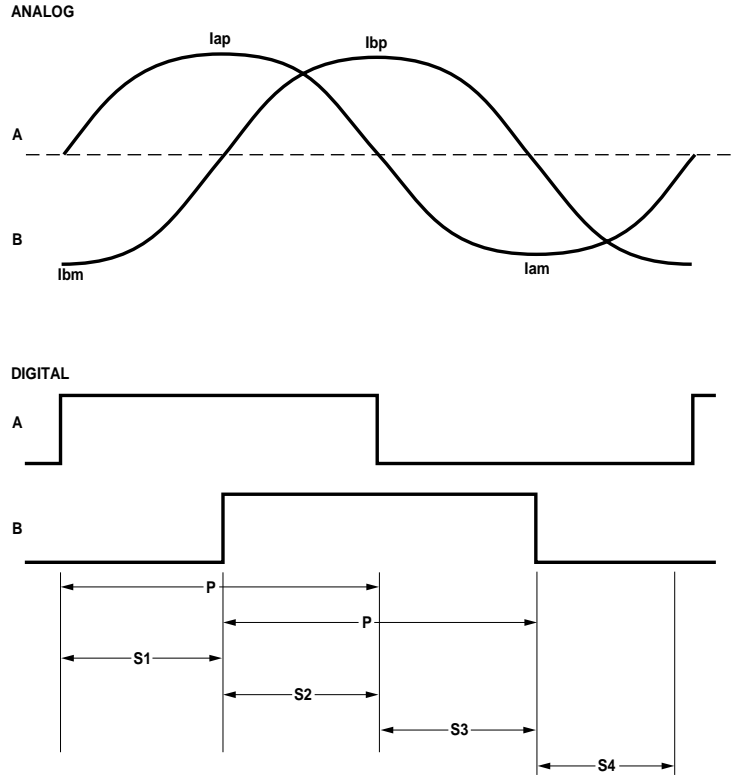

Name	Parameter	Definition	Label
Analog Peak		The absolute value in μA of the magnitude of the analog signal (i.e., one-sided reading).	$l_{ap}, l_{bp}, l_{am}, l_{bm}$
Analog Peak-to-Peak	I_{pp}	The peak-to-peak signal magnitude in μA of the analog signal.	l_{app}, l_{bpp}
Analog Offset	I_{offset}	The offset in μA from the mid-point of the analog peak-to-peak signal to the zero current point.	
State Width	State Width	The number of electrical degrees between a transition in channel A and the neighboring transition in channel B. There are four states per cycle, each nominally 90° . The transitions are determined by where the analog signal crosses the Zero point.	State 1 State 2 State 3 State 4
State Width Error	State Width Error	The deviation, in electrical degrees, of each state width from its ideal value of 90° .	
Pulse Width	Pulse Width	The number of electrical degrees that an analog output is greater than zero during one cycle. This value is nominally 180° or $1/2$ cycle.	P
Pulse Width Error	Pulse Width Error	The deviation, in electrical degrees, of each pulse width from its ideal value of 180° .	

Electrical Characteristics

Electrical Characteristics over Recommended Operating Range, Typical at $25^\circ C$.

Parameter	Symbol	Min.	Typ.	Max.	Units	Notes
Supply Current	I_{CC}		17	40	mA	

Encoding Characteristics

Encoding Characteristics over Recommended Operating Range and Recommended Mounting Tolerances.
 These characteristics do not include codewheel/codestrip contributions.

	Units		
Radial	microns	± 130	
Tangential	microns	± 130	
Gap	microns	50 – 250	
Temperature	$^{\circ}\text{C}$	15 – 45	
O.R.	mm	18 – Linear	
CPR	count	900 – Linear	
Codewheel Slot/Spoke	ratio	0.9 – 1.1	
		Min.	Max.
I_{pp}	μA	10	73
I_{offset}	μA	-4	+4
State Width Error	e°	-40	+40
Pulse Width Error	e°	-40	+40

Recommended Codewheel and Codestrip Characteristics

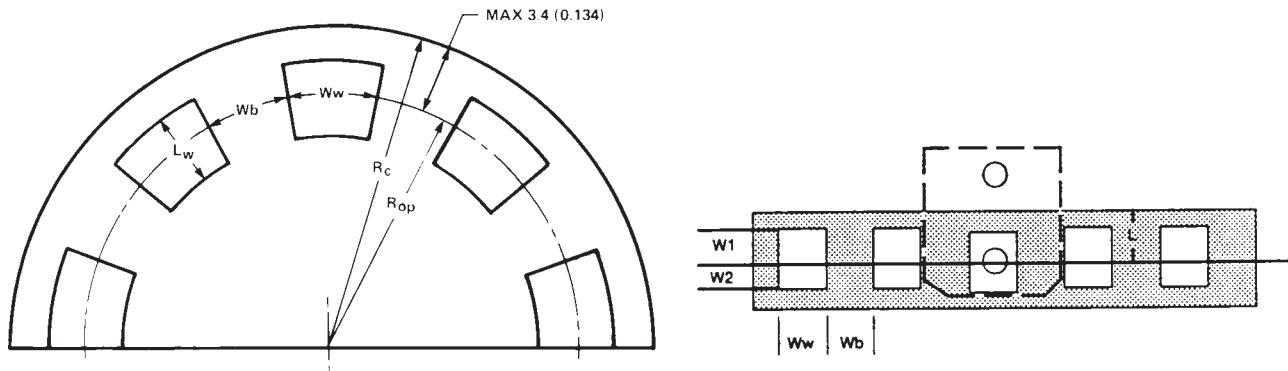

Parameter	Symbol	Min.	Max.	Units	Notes
Window/Bar Ratio	Ww/Wb	0.9	1.1		
Window Length (Rotary)	Lw	1.80 (0.071)	2.30 (0.091)	mm (inch)	
Absolute Maximum Codewheel Radius (Rotary)	Rc		Rop + 3.40 (Rop + 0.134)	mm (inch)	Includes eccentricity errors
Center of Post to Inside Edge of Window	W1	1.04 (0.041)		mm (inch)	
Center of Post to Outside Edge of Window	W2	0.76 (0.030)		mm (inch)	
Center of Post to Inside Edge of Codestrip	L		3.60 (0.142)	mm (inch)	

Analog Encoder Interface Circuit

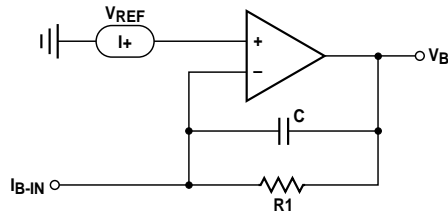
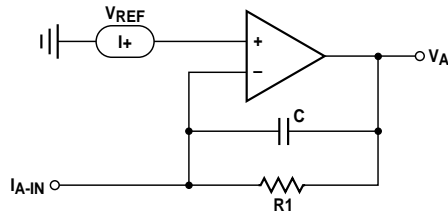

$V_{REF} = 1.4 \text{ V} \pm 0.2 \text{ V (DC)}$

The circuit shown can be used to convert the current output to a voltage. Resistor value, $R1$, and Capacitor, C , are specified to attain required gain and low-pass filtering, which are application specific. The gain is chosen to attain maximum output swing and not clamp the op-amp. V_{REF} should be set to $1.4 \text{ V} \pm 0.2 \text{ V}$. A $0.1 \mu\text{F}$ bypass capacitor (decoupling capacitor) is recommended to be placed within 1 cm of the encoder for optimal power supply noise rejection. Outputs are high impedance (typical 1 M ohm) and susceptible to EMI.

Ordering Information

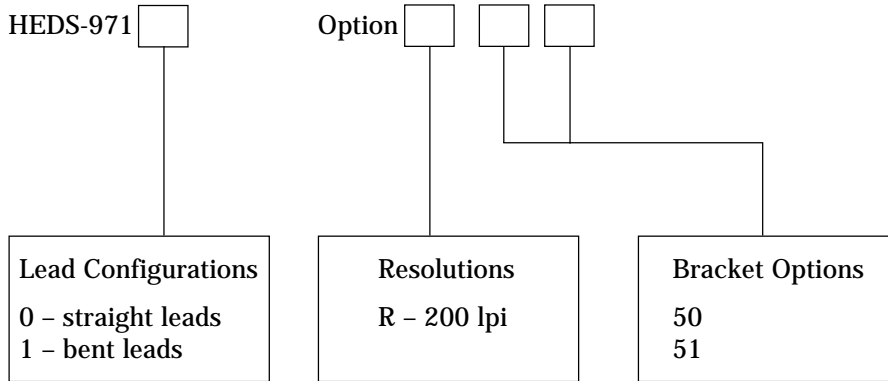

Package Dimensions

Option 50

LEAD THICKNESS = 0.25 mm
LEAD PITCH = 2.54 mm

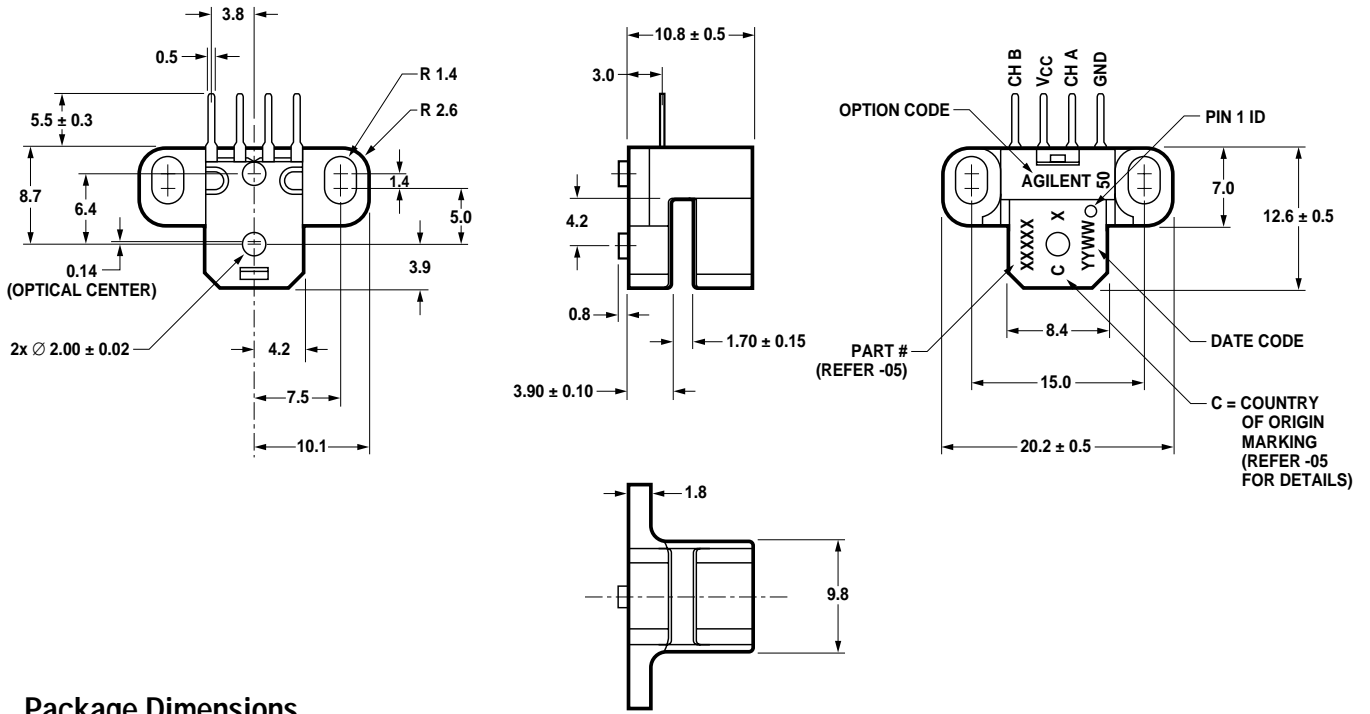

Package Dimensions

Option 51

LEAD THICKNESS = 0.25 mm
LEAD PITCH = 2.54 mm

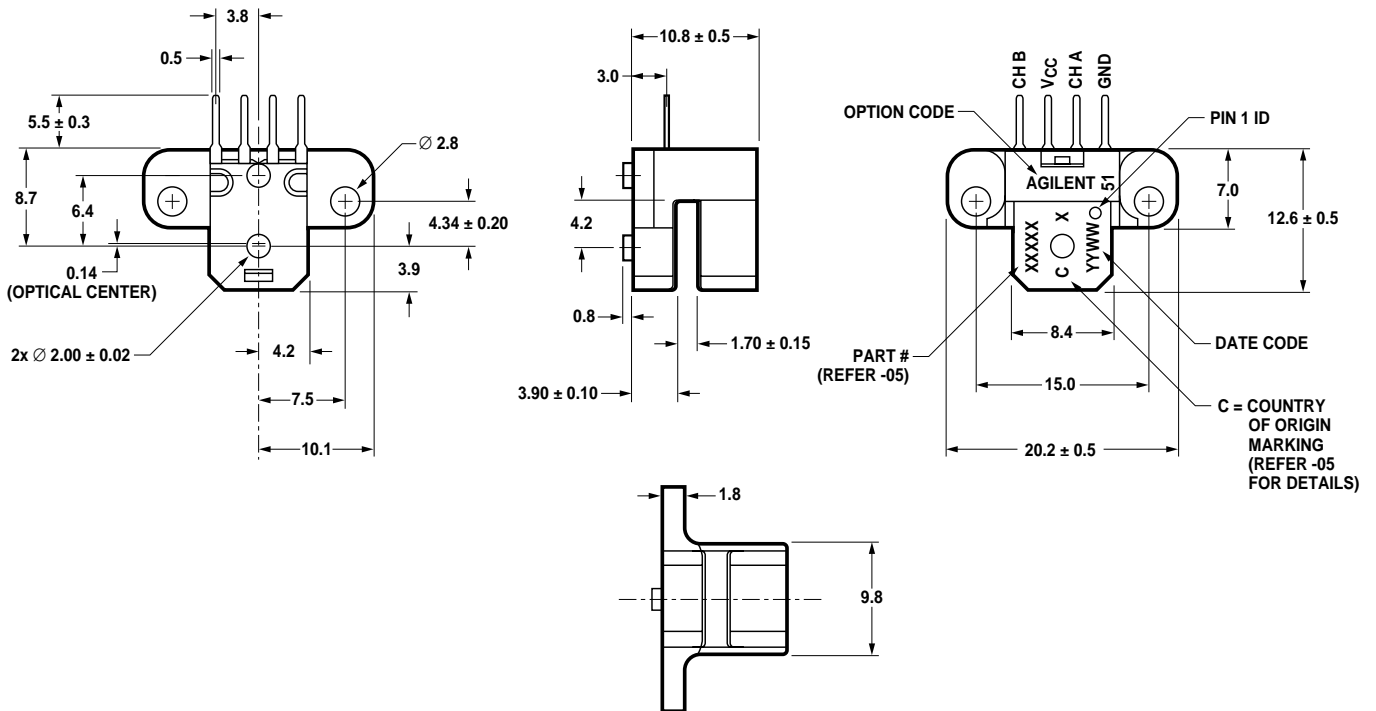

Package Dimensions

Bent Version – Option 50

LEAD THICKNESS = 0.25 mm
LEAD PITCH = 2.54 mm

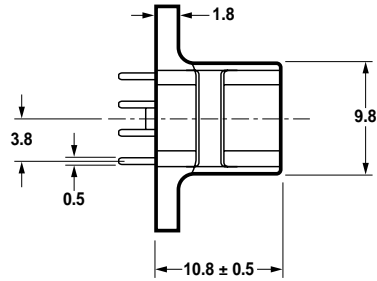
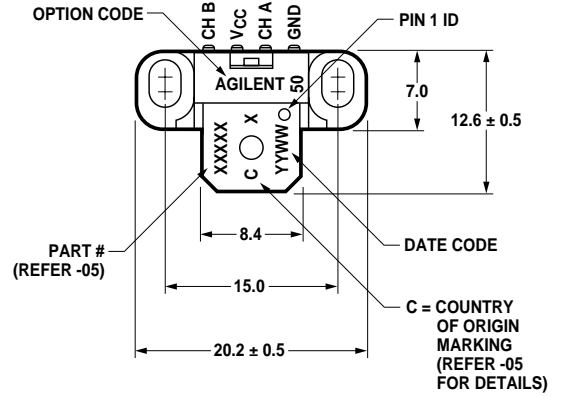
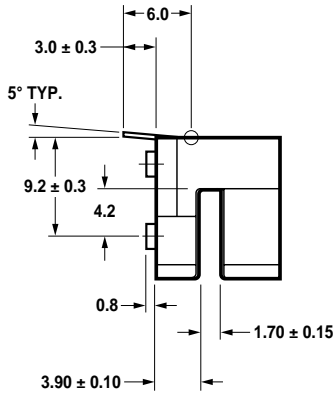
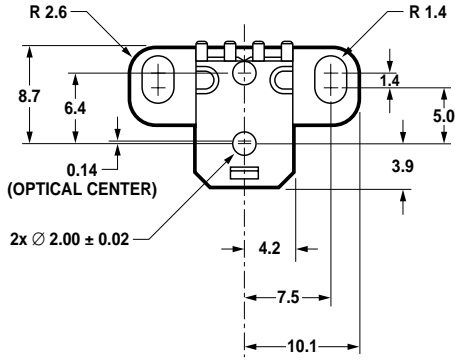

Package Dimensions

Bent Version – Option 51

LEAD THICKNESS = 0.25 mm
LEAD PITCH = 2.54 mm

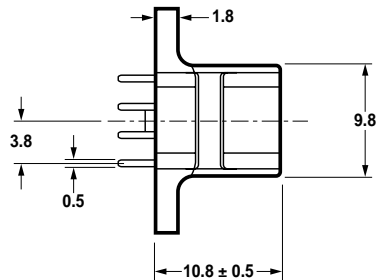
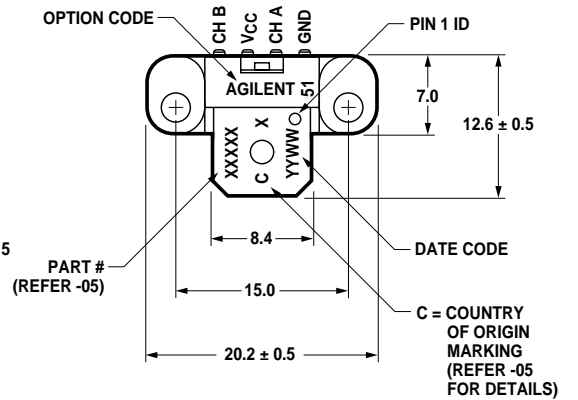
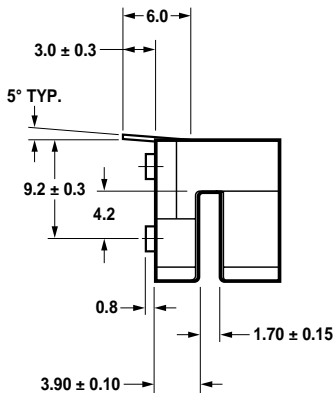
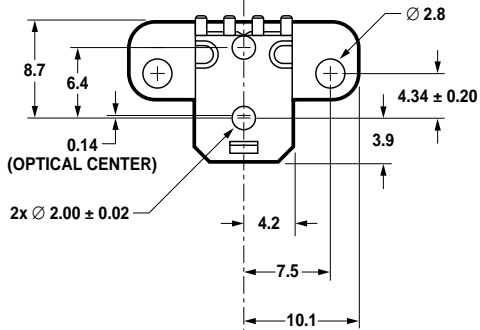

Mounting Considerations

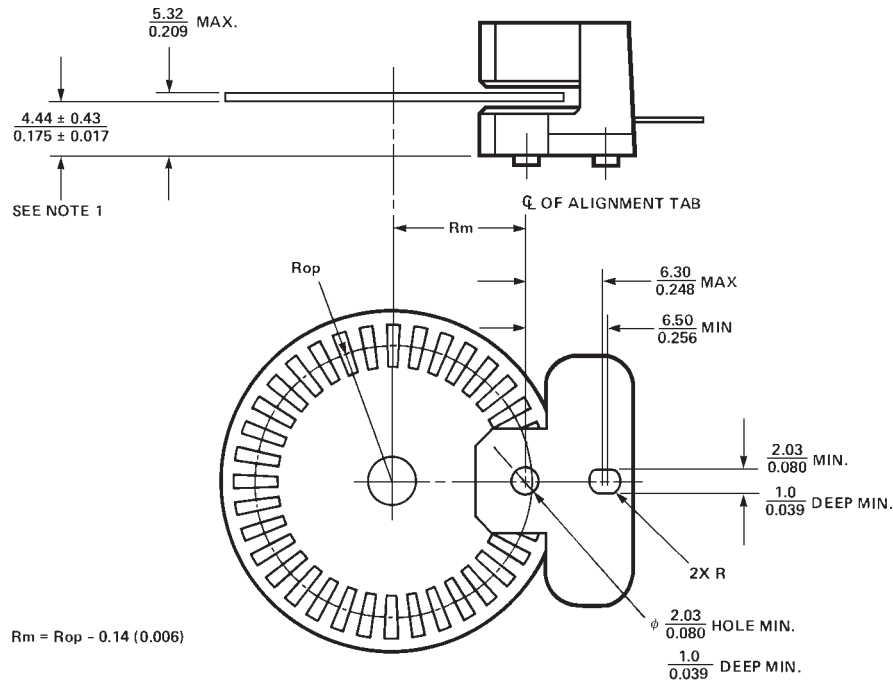

Note: These dimensions include shaft end play and codewheel warp.

All dimensions for mounting the module and codewheel/codestrip should be measured with respect to the two mounting posts, shown above.

Mounting Tolerances

Case 1 specifies the mounting tolerances required on R_m in order to achieve the respective encoding characteristics shown on page 4. The mounting tolerances are as follows:

Case 1: $R_m \pm 0.13$ mm (.005 inches)

Recommended Screw Size: M2.5 x 0.45 or 2-56

For product information and a complete list of distributors, please go to our website: www.avagotech.com

Avago, Avago Technologies, and the A logo are trademarks of Avago Technologies Limited in the United States and other countries. Data subject to change. Copyright © 2006 Avago Technologies Limited. All rights reserved. Obsoletes 5988-3614EN 5988-6261EN June 19, 2006

AVAGO
TECHNOLOGIES