

Evaluation board using PD54008L-E for 2-way UHF radio

Features

- Excellent thermal stability
- Frequency: 400 - 470 MHz
- Supply voltage: 7.2 V
- Output power: 8 W
- Power gain: 12.0 ± 1.0 dB
- Efficiency: 56 % - 68 %
- Load mismatch: 20:1
- BeO-free amplifier

Description

The DB-54008L-470 is an evaluation board using PD54008L-E LDMOS transistor and designed for 2 Ways UHF portable radio.

For additional informations on PD54008L-E, please refer to its datasheet.

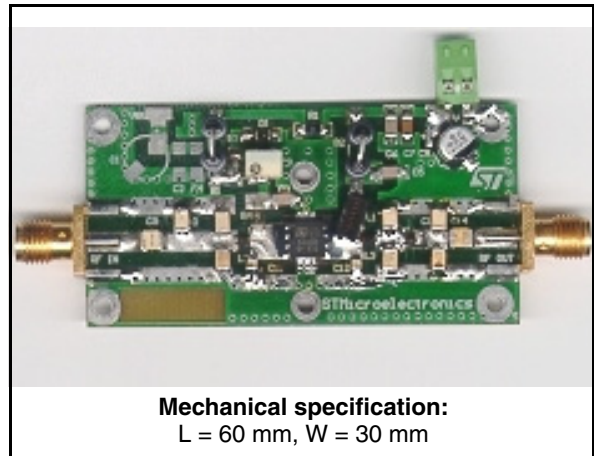

Table 1. Device summary

Order code
DB-54008L-470

Contents

1	Electrical data	3
	1.1 Maximum ratings	3
2	Electrical characteristics	3
3	Impedance	4
4	Typical performance	5
5	Test circuit	8
6	Circuit layout	10
7	Mounting indications - PD54008L-E	11
8	Package mechanical data - PD54008L-E	12
9	Revision history	15

1 Electrical data

1.1 Maximum ratings

Table 2. Absolute maximum ratings

Symbol	Parameter	Value	Unit
V_{DD}	Supply voltage	16	V
I_D	Drain current	2.5	A
T_{CASE}	Operating case temperature	-20 to +85	°C
T_A	Maximum ambient temperature	+55	°C

2 Electrical characteristics

$T_A = +25\text{ °C}$, $V_{DD} = 7.5\text{ V}$, $I_{dq} = 50\text{ mA}$

Table 3. Electrical specifications

Symbol	Test conditions	Min	Typ	Max	Unit
Freq	Frequency range	400		470	MHz
P_{OUT}		7	8		W
Gain	@ $P_{OUT} = 8\text{ W}$		12.0 ± 1.0		dB
ND	@ $P_{OUT} = 8\text{ W}$		56 - 68		%
H2	2nd harmonic @ $P_{OUT} = 8\text{ W}$		-28 / -44		dBc
H3	3rd harmonic @ $P_{OUT} = 8\text{ W}$		-58 / -61		dBc
VSWR	Load mismatch all phases @ $P_{OUT} = 8\text{ W}$			20:1	

3 Impedance

Figure 1. Impedance illustration

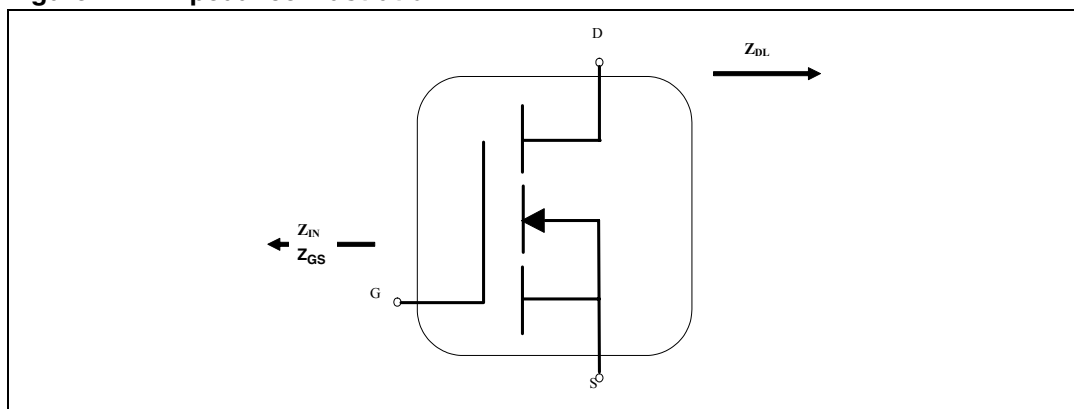

Table 4. Impedance data

F(MHz)	Z_{GS}	Z_{DL}
400	$1.588 + j3.459$	$2.128 + j1.795$
410	$1.772 + j3.516$	$2.175 + j2.026$
420	$1.912 + j3.440$	$2.236 + j2.266$
430	$1.827 + j3.236$	$2.304 + j2.465$
440	$1.432 + j3.145$	$2.341 + j2.630$
450	$0.982 + j3.368$	$2.385 + j2.771$
460	$0.682 + j3.742$	$2.422 + j2.844$
470	$0.521 + j4.204$	$2.410 + j2.888$

4 Typical performance

Figure 2. Output power vs input power

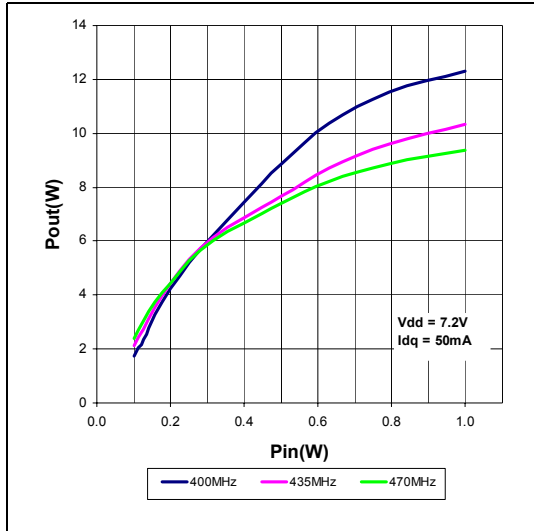

Figure 3. Gain and efficiency vs output power

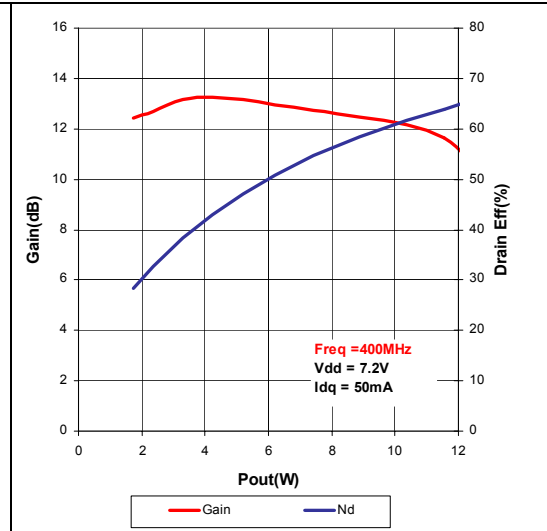

Figure 4. Gain and efficiency vs output power

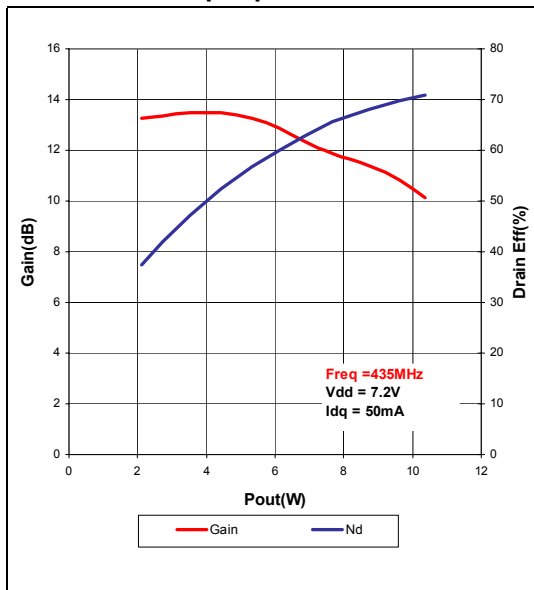

Figure 5. Gain and efficiency vs output power

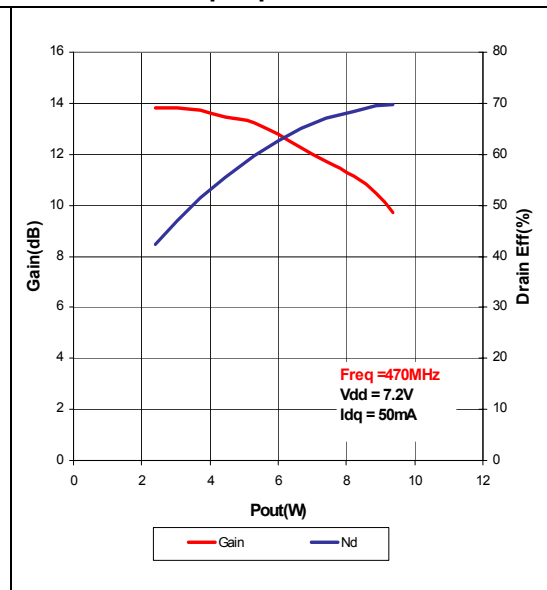

Figure 6. Gain and efficiency vs frequency

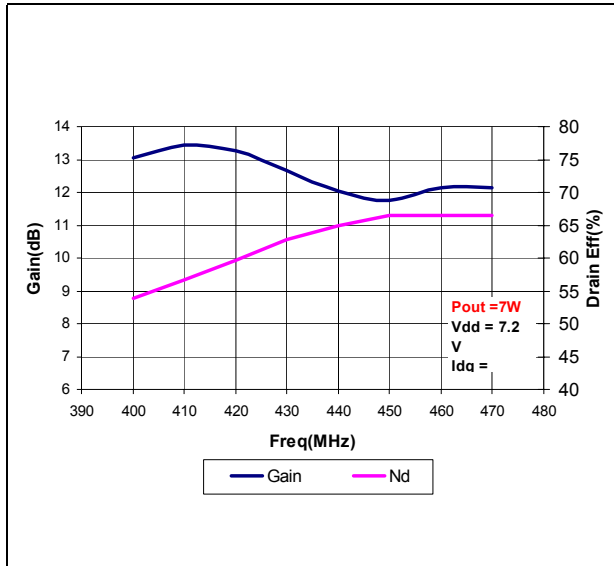

Figure 7. Gain and efficiency vs frequency

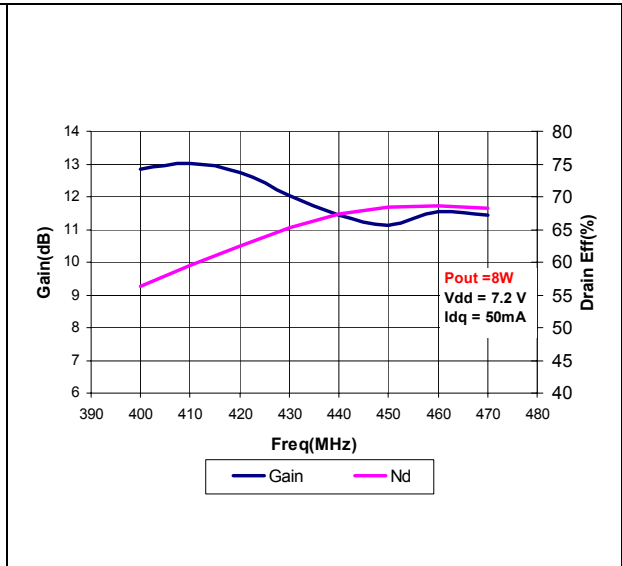

Figure 8. Input return loss vs frequency

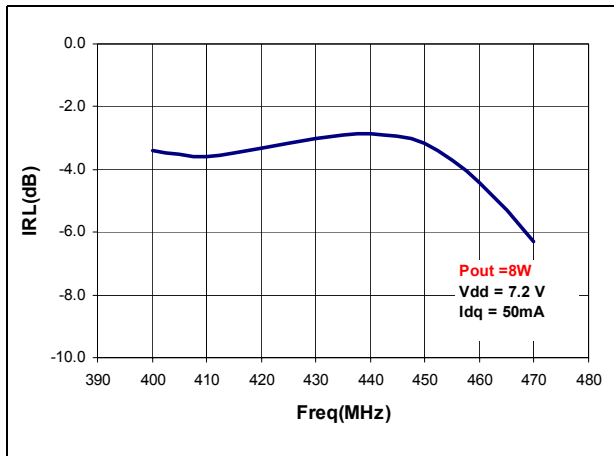

Figure 9. Harmonics vs frequency

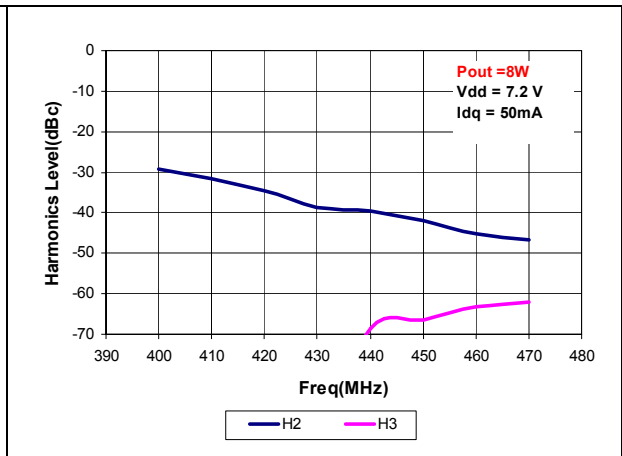
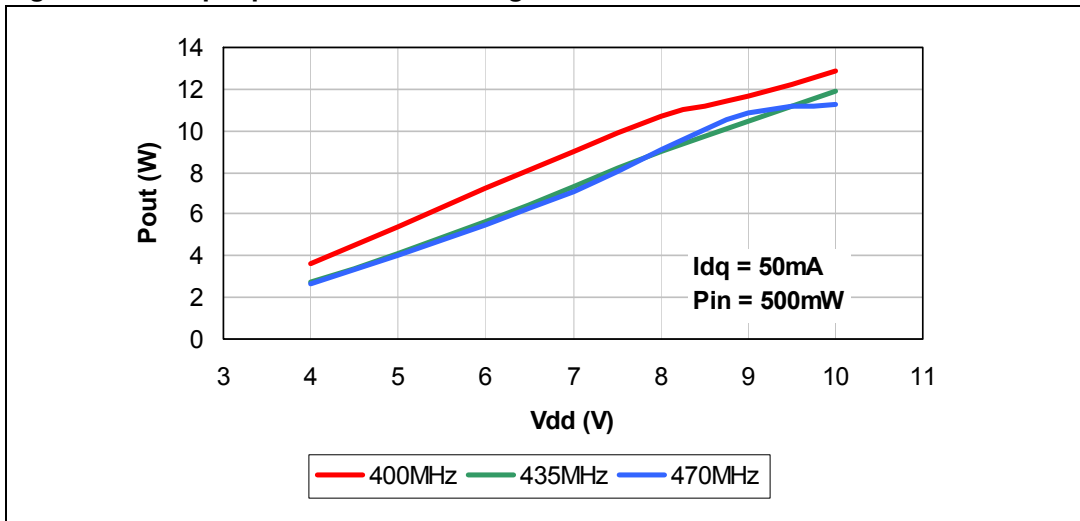

Figure 10. Output power vs drain voltage



5 Test circuit

Figure 11. Test circuit schematic

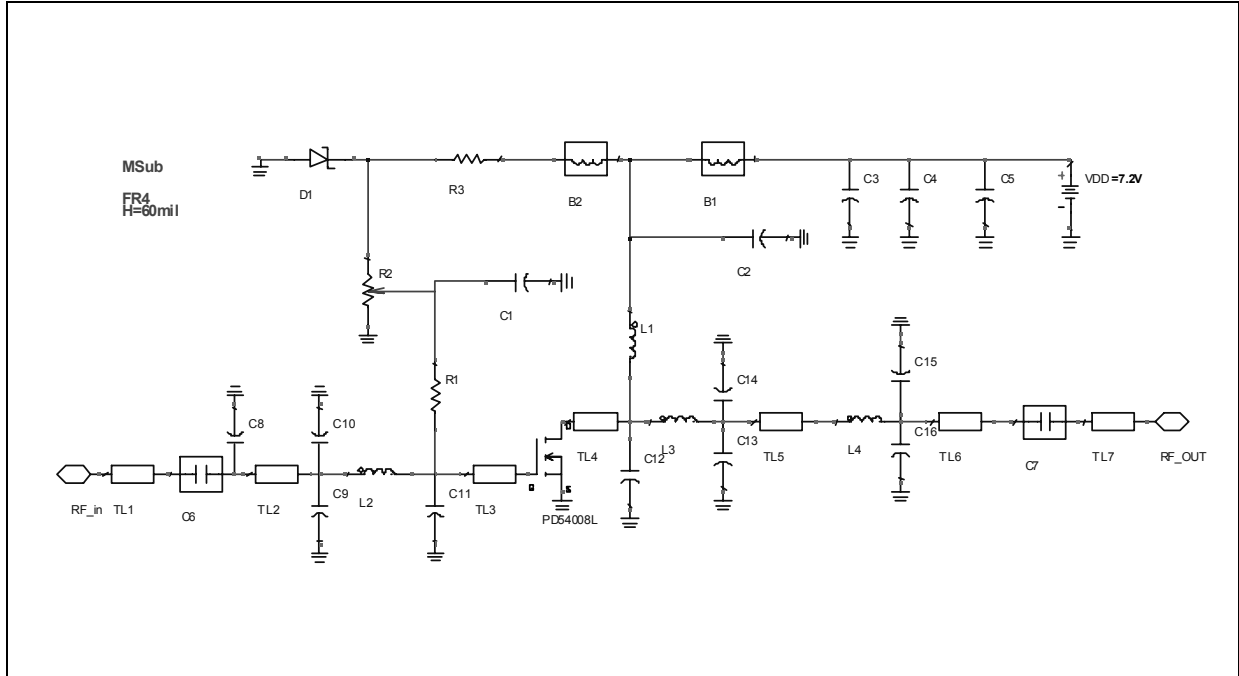

Table 5. Part list

Component ID	Description	Value	Case size	Manufacturer	Part code
C4	Capacitor	10 nF	1206	Murata	GRM42-6X7R104K50
C3	Capacitor	1 nF	1206	Murata	GRM42-6C0G102J50
C1	Capacitor	120 pF	1206	Murata	GRM42-6C0G121J50
C2	Capacitor	120 pF	1206	Murata	GRM42-6C0G121J50
C6	Capacitor	120 pF	100B	ATC	121
C7	Capacitor	120 pF	100B	ATC	121
C8	Capacitor	2 pF	100B	ATC	2R0
C9	Capacitor	13 pF	100B	ATC	130
C10	Capacitor	20 pF	100B	ATC	200
C11	Capacitor	62 pF	100A	ATC	620
C12	Capacitor	43 pF	100A	ATC	430
C13	Capacitor	4.3 pF	100B	ATC	4R3
C14	Capacitor	15 pF	100B	ATC	150
C15	Capacitor	3 pF	100B	ATC	3R0
C16	Capacitor	6.8 pF	100B	ATC	6R8

Table 5. Part list (continued)

Component ID	Description	Value	Case size	Manufacturer	Part code
C5	Capacitor	10 μ F	SMT	Panasonic	EEVHB1V100P
B2	Ferrite bead			Panasonic	EXCELDRC35C
B1	Ferrite bead			Panasonic	EXCELDRC35C
L1	Inductor	35.5 nH		Coilcraft	B09T
R2	Potentiometer	10 k Ω		Bourns Electronics	3214W-1-103E
R3	Resistor	1 k Ω	1206	Tyco Electronics	01623440-1
R1	Resistor	15 Ω	1206	Tyco Electronics	01623429-1
RF in	SMA-CONN			Johnson	142-0701-801
RF out	SMA-CONN			Johnson	142-0701-801
TL1	Transmission line	W=2.87 mm	L=8.6 mm		
TL2	Transmission line	W=2.87 mm	L=11.7 mm		
TL3	Transmission line	W=4.90 mm	L=5.6 mm		
TL4	Transmission line	W=4.90 mm	L=5.8 mm		
TL5	Transmission line	W=2.87 mm	L=6.4 mm		
TL6	Transmission line	W=2.87 mm	L=4.5 mm		
TL7	Transmission line	W=2.87 mm	L=6.8 mm		
D1	Zener diode	5.1 V	SOD110	Philips	BZX284C5V1
L2	2.55 nH	0906		Coilcraft	0906-3
L3	1.65 nH	0906		Coilcraft	0906-2
L4	3.85 nH	0906		Coilcraft	0906-4
PD54008L	LD MOS			STMicroelectronics	PD54008L
Board: FR-4 THk=0.060" 2 OZ Cu both sides					

6 Circuit layout

Figure 12. Test fixture component layout

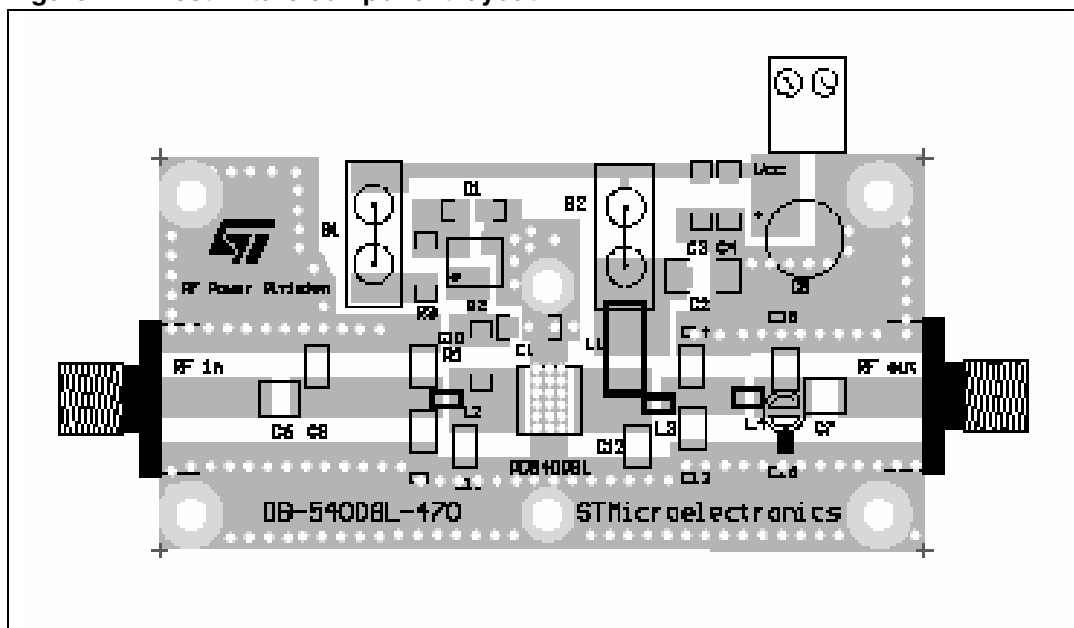
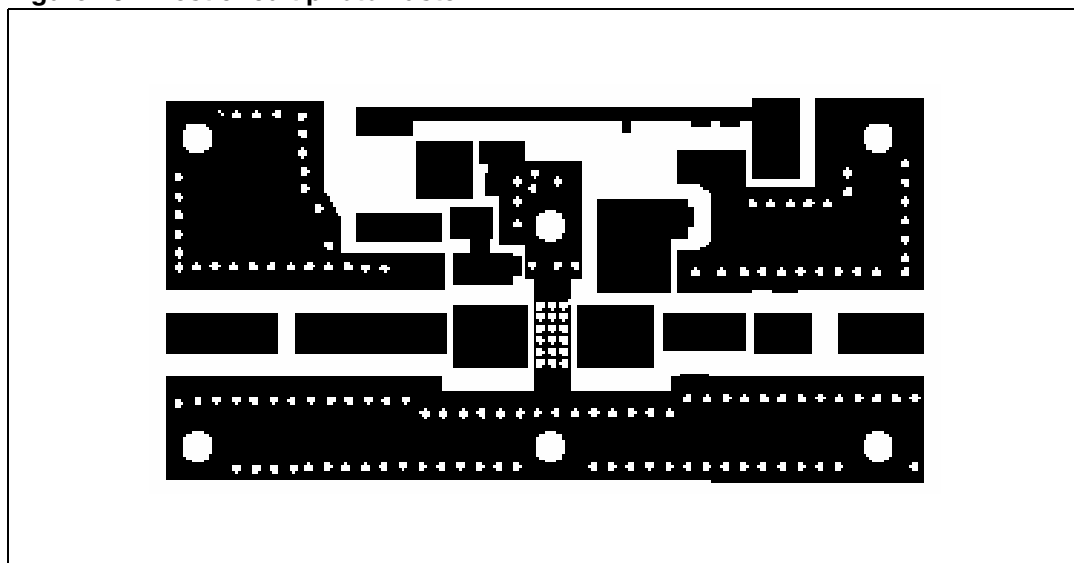
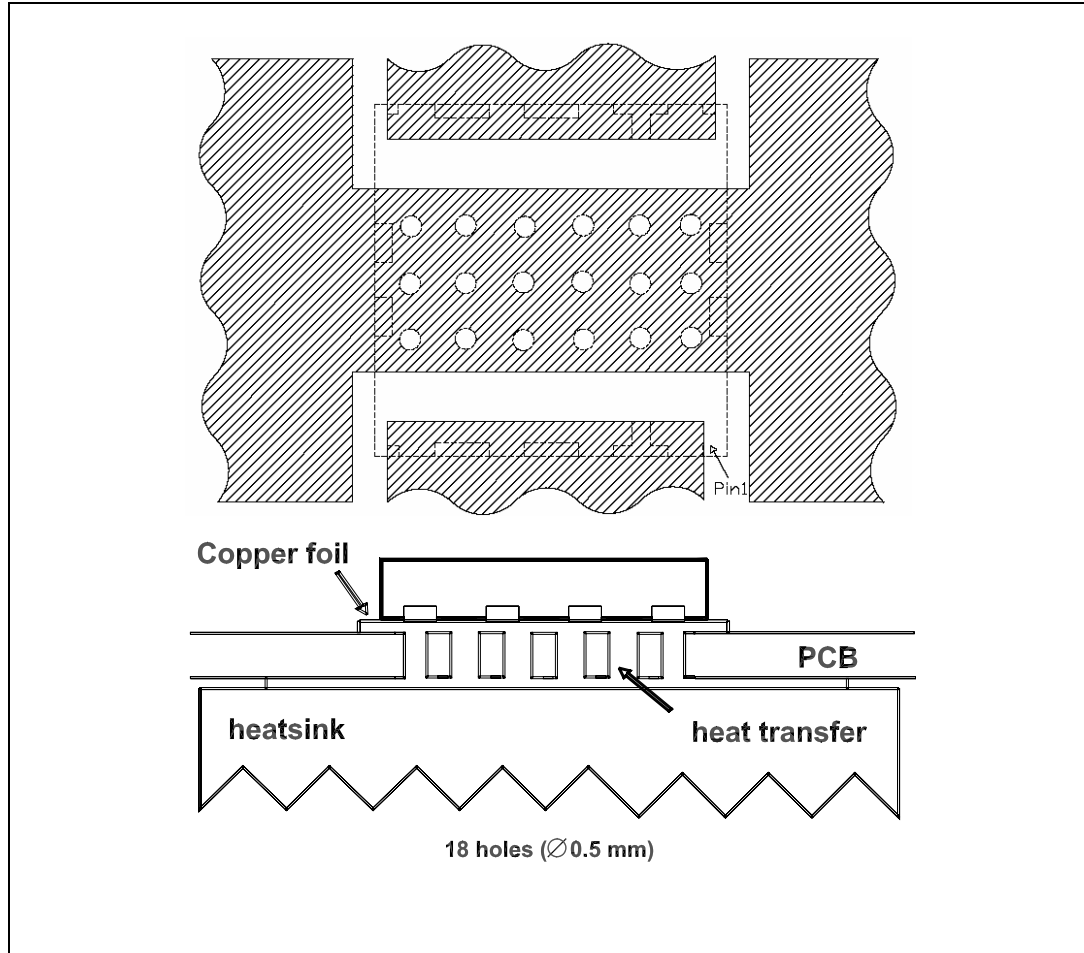

Figure 13. Test circuit photomaster



7 Mounting indications - PD54008L-E

Figure 14. Standard SMD mounting



8 Package mechanical data - PD54008L-E

In order to meet environmental requirements, ST offers these devices in ECOPACK® packages. These packages have a lead-free second level interconnect . The category of second level interconnect is marked on the package and on the inner box label, in compliance with JEDEC Standard JESD97. The maximum ratings related to soldering conditions are also marked on the inner box label. ECOPACK is an ST trademark. ECOPACK specifications are available at: www.st.com

The following package information refers to the PD54008L-E RF power transistor in the PowerFLAT package mounted on the evaluation board

Table 6. PowerFLAT™ mechanical data

Dim.	mm			inch		
	Min	Typ	Max	Min	Typ	Max
A		0.90	1.00		0.035	0.039
A1		0.02	0.05		0.001	0.002
A3		0.24			0.009	
AA	0.15	0.25	0.35	0.006	0.01	0.014
b	0.43	0.51	0.58	0.017	0.020	0.023
c	0.64	0.71	0.79	0.025	0.028	0.031
D		5.00			0.197	
d		0.30			0.011	
E		5.00			0.197	
E2	2.49	2.57	2.64	0.098	0.101	0.104
e		1.27			0.050	
f		3.37			0.132	
g		0.74			0.03	
h		0.21			0.008	

Figure 15. PowerFLAT™ package dimensions

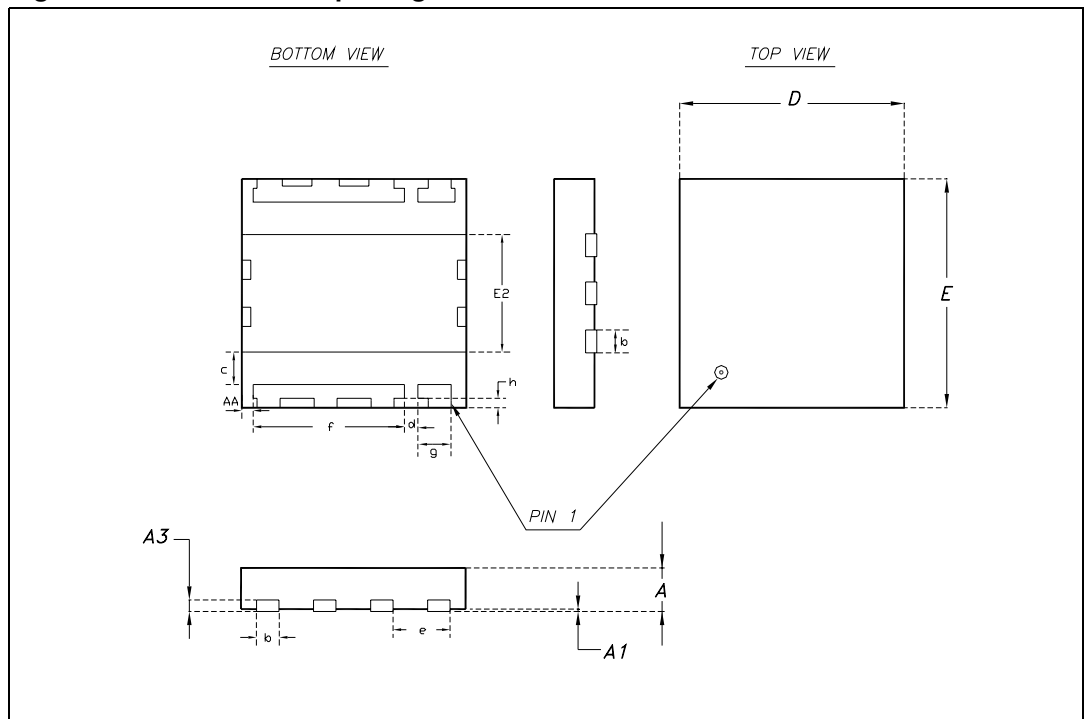
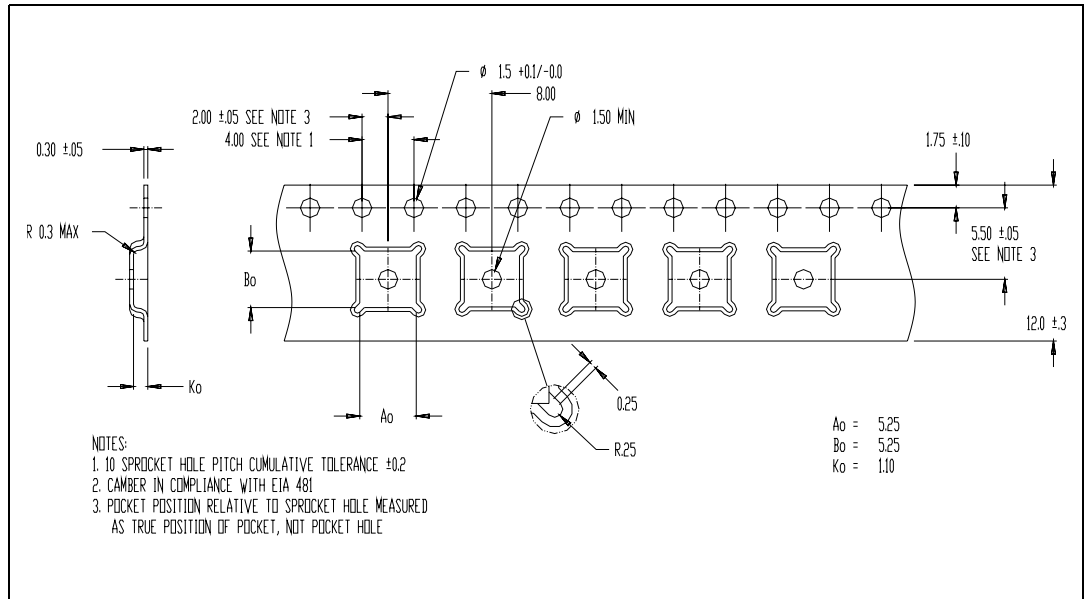

Table 7. PowerFLAT™ tape and reel dimensions

Dim.	mm			inch		
	Min	Typ	Max	Min	Typ	Max
Ao	5.15	5.25	5.35	0.12	0.13	0.13
Bo	5.15	5.25	5.35	0.12	0.13	0.13
Ko	1.0	1.1	1.2	0.02	0.02	0.02

Figure 16. PowerFLAT™ tape and reel



9 Revision history

Table 8. Document revision history

Date	Revision	Changes
19-May-2006	1	Initial release
19-Jan-2007	2	Added component list table
21-Nov-2007	3	Updated: Photo in coverpage, Table 4: Impedance data on page 4 , Section 4: Typical performance on page 5 , Figure 11: Test circuit schematic , Table 5: Part list on page 8

Please Read Carefully:

Information in this document is provided solely in connection with ST products. STMicroelectronics NV and its subsidiaries ("ST") reserve the right to make changes, corrections, modifications or improvements, to this document, and the products and services described herein at any time, without notice.

All ST products are sold pursuant to ST's terms and conditions of sale.

Purchasers are solely responsible for the choice, selection and use of the ST products and services described herein, and ST assumes no liability whatsoever relating to the choice, selection or use of the ST products and services described herein.

No license, express or implied, by estoppel or otherwise, to any intellectual property rights is granted under this document. If any part of this document refers to any third party products or services it shall not be deemed a license grant by ST for the use of such third party products or services, or any intellectual property contained therein or considered as a warranty covering the use in any manner whatsoever of such third party products or services or any intellectual property contained therein.

UNLESS OTHERWISE SET FORTH IN ST'S TERMS AND CONDITIONS OF SALE ST DISCLAIMS ANY EXPRESS OR IMPLIED WARRANTY WITH RESPECT TO THE USE AND/OR SALE OF ST PRODUCTS INCLUDING WITHOUT LIMITATION IMPLIED WARRANTIES OF MERCHANTABILITY, FITNESS FOR A PARTICULAR PURPOSE (AND THEIR EQUIVALENTS UNDER THE LAWS OF ANY JURISDICTION), OR INFRINGEMENT OF ANY PATENT, COPYRIGHT OR OTHER INTELLECTUAL PROPERTY RIGHT.

UNLESS EXPRESSLY APPROVED IN WRITING BY AN AUTHORIZED ST REPRESENTATIVE, ST PRODUCTS ARE NOT RECOMMENDED, AUTHORIZED OR WARRANTED FOR USE IN MILITARY, AIR CRAFT, SPACE, LIFE SAVING, OR LIFE SUSTAINING APPLICATIONS, NOR IN PRODUCTS OR SYSTEMS WHERE FAILURE OR MALFUNCTION MAY RESULT IN PERSONAL INJURY, DEATH, OR SEVERE PROPERTY OR ENVIRONMENTAL DAMAGE. ST PRODUCTS WHICH ARE NOT SPECIFIED AS "AUTOMOTIVE GRADE" MAY ONLY BE USED IN AUTOMOTIVE APPLICATIONS AT USER'S OWN RISK.

Resale of ST products with provisions different from the statements and/or technical features set forth in this document shall immediately void any warranty granted by ST for the ST product or service described herein and shall not create or extend in any manner whatsoever, any liability of ST.

ST and the ST logo are trademarks or registered trademarks of ST in various countries.

Information in this document supersedes and replaces all information previously supplied.

The ST logo is a registered trademark of STMicroelectronics. All other names are the property of their respective owners.

© 2007 STMicroelectronics - All rights reserved

STMicroelectronics group of companies

Australia - Belgium - Brazil - Canada - China - Czech Republic - Finland - France - Germany - Hong Kong - India - Israel - Italy - Japan - Malaysia - Malta - Morocco - Singapore - Spain - Sweden - Switzerland - United Kingdom - United States of America

www.st.com