

---

**Evaluation board using PD55008L-E for UHF RFID reader**

---

**Features**

- Excellent thermal stability
- Frequency: 860 - 960 MHz
- Supply voltage: 12 V
- Output power: 7 W
- Efficiency: 46 % - 55 %
- Load mismatch: 20:1
- Beo free amplifier

**Description**

The DB-55008L-960 is an evaluation board using PD55008L-E LDMOS transistor and designed for UHF portable RFID reader covering Europe, USA/Canada and Japan frequency bands.

For additional informations on PD55008L-E, please refer to its datasheet.

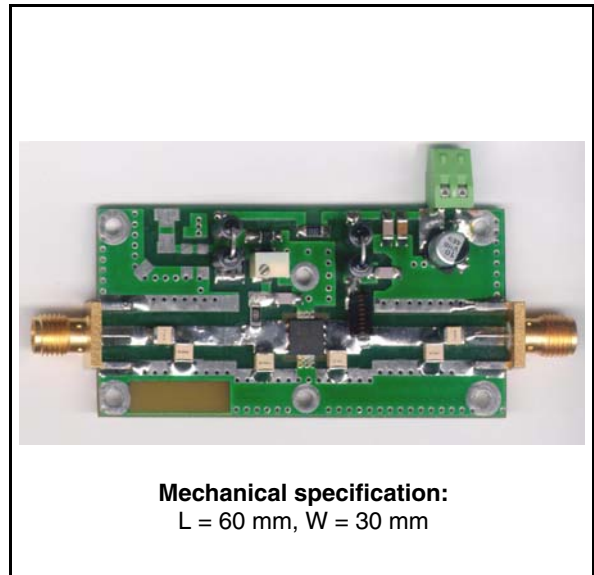
**Table 1. Device summary**

Part number
DB-55008L-960

# Contents

<b>1</b>	<b>Electrical data</b> .....	<b>3</b>
	1.1 Maximum ratings .....	3
<b>2</b>	<b>Electrical characteristics</b> .....	<b>3</b>
<b>3</b>	<b>Impedance</b> .....	<b>4</b>
<b>4</b>	<b>Typical performances</b> .....	<b>5</b>
<b>5</b>	<b>Circuit layout</b> .....	<b>8</b>
<b>6</b>	<b>Mounting indications - PD55008L-E</b> .....	<b>10</b>
<b>7</b>	<b>Package mechanical data - PD55008L-E</b> .....	<b>11</b>
<b>8</b>	<b>Revision history</b> .....	<b>14</b>

# 1 Electrical data

## 1.1 Maximum ratings

**Table 2. Absolute maximum ratings**

Symbol	Parameter	Value	Unit
$V_{DD}$	Supply voltage	16	V
$I_D$	Drain current	1.6	A
$P_{DISS}$	Drain current	10	W
$T_{CASE}$	Operating case temperature	-20 to +85	°C
$T_A$	Max. ambient temperature	+55	°C

## 2 Electrical characteristics

$T_A = +25\text{ °C}$ ,  $V_{DD} = 12\text{ V}$ ,  $I_{dq} = 100\text{ mA}$

**Table 3. Electrical specification**

Symbol	Test conditions	Min	Typ	Max	Unit
Freq	Frequency range	860		960	MHz
$P_{OUT}$			7		W
Gain	@ $P_{OUT} = 7\text{ W}$		9.5		dB
ND	@ $P_{OUT} = 7\text{ W}$	45		55	%
GAIN Flatness	@ $P_{OUT} = 7\text{ W}$			±0.8	dB
H2	2 <sup>ND</sup> Harmonic @ $P_{OUT} = 7\text{ W}$		-54	-50	dBc
H3	3 <sup>RD</sup> Harmonic @ $P_{OUT} = 7\text{ W}$		-44	-40	dBc
VSWR	Load mismatch all phases @ $P_{OUT} = 7\text{ W}$			20:1	

### 3 Impedance

Table 4. Impedance data

F(MHz)	$Z_{GS}$	$Z_{DL}$
840	$2.20 + j0.2$	$2.95 + j2.4$
860	$2.05 + j0.8$	$2.95 + j2.7$
880	$1.87 + j1.4$	$2.93 + j2.9$
900	$1.70 + j2.0$	$2.86 + j3.1$
920	$1.54 + j2.6$	$2.73 + j3.15$
940	$1.40 + j3.2$	$2.50 + j3.2$
960	$1.26 + j3.7$	$2.14 + j3.3$

# 4 Typical performances

**Figure 1. Gain and efficiency vs frequency**

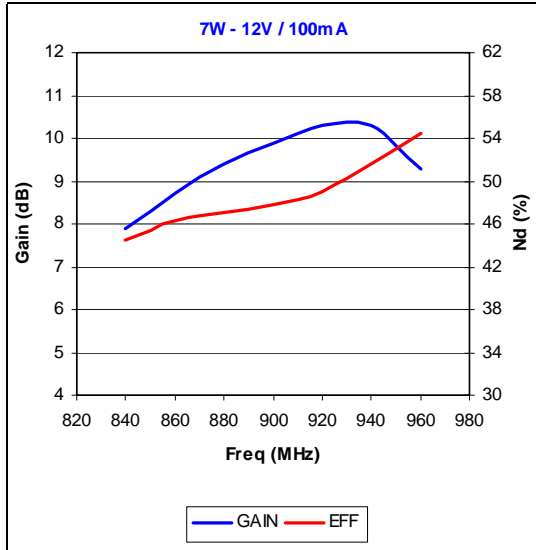

**Figure 2. Gain and efficiency vs frequency**

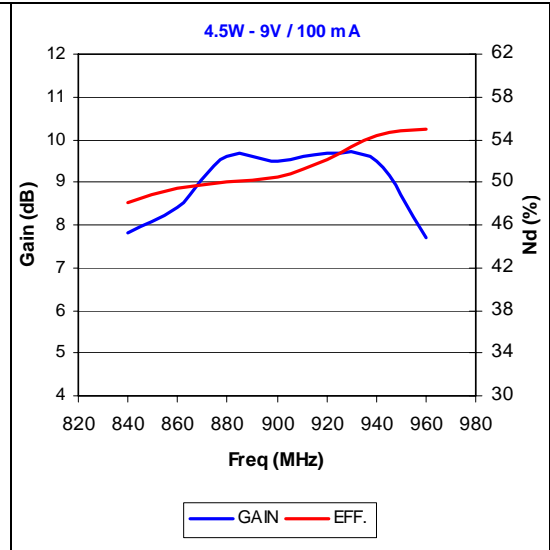

**Figure 3. Gain and efficiency vs frequency**

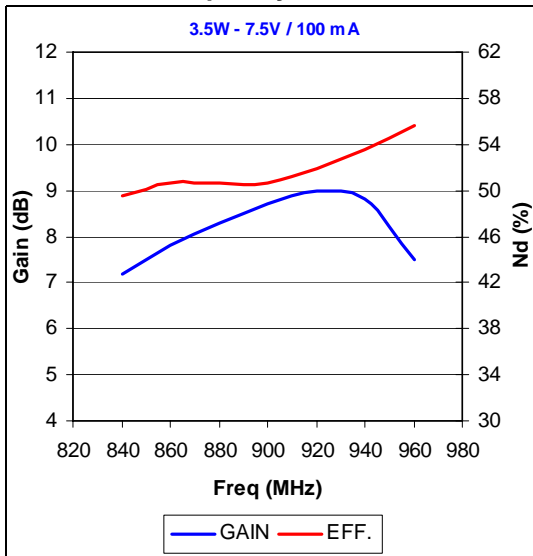

**Figure 4. Gain and efficiency vs frequency**

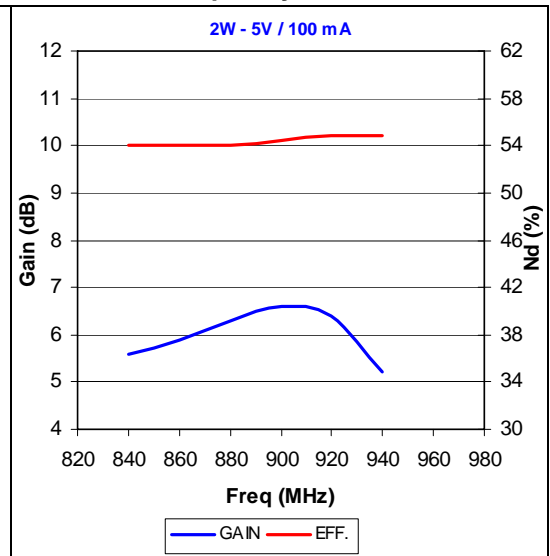

Figure 5. Input return loss vs frequency

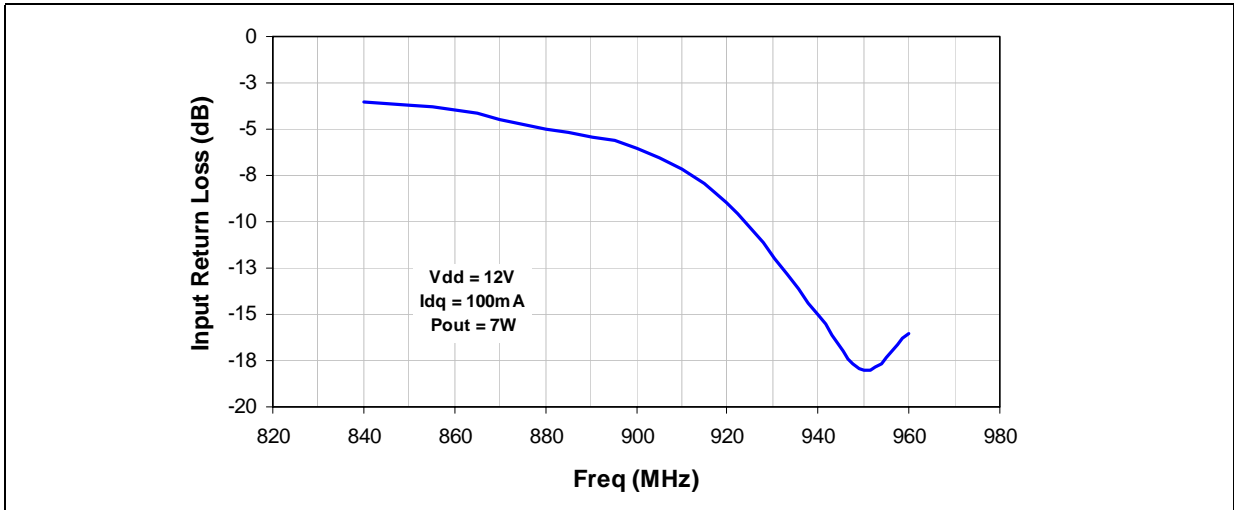

Figure 6. Output power vs input power

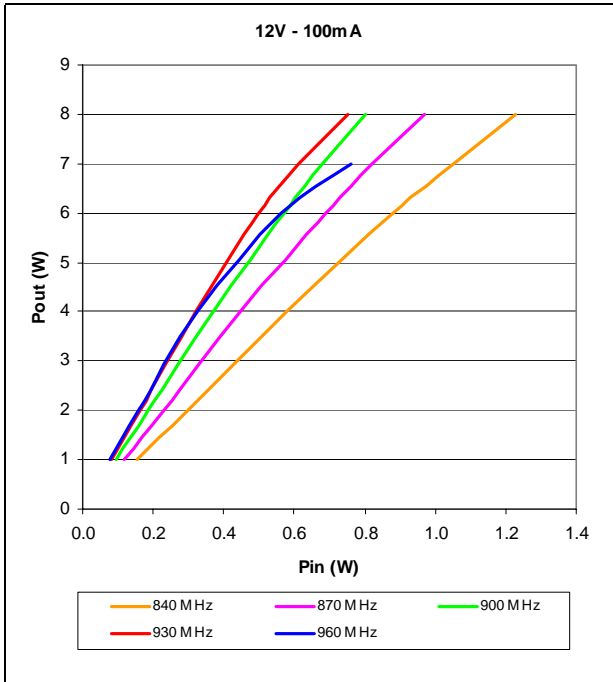

Figure 7. Drain efficiency vs output power

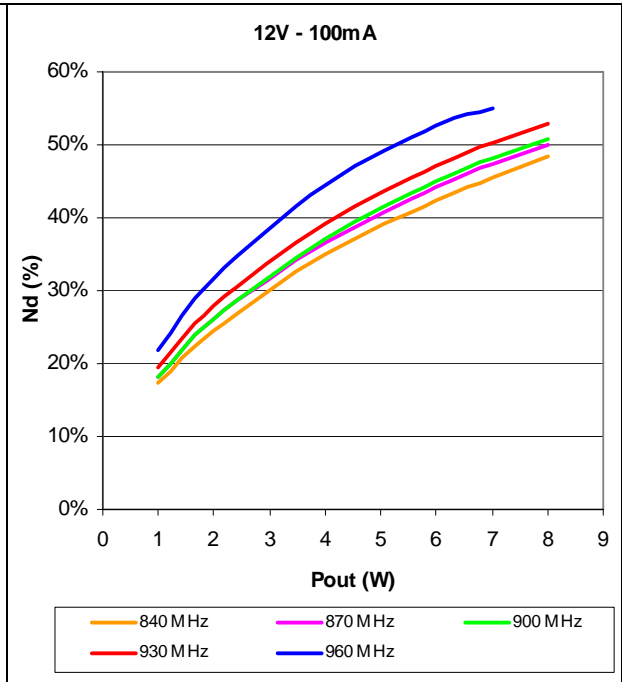

Figure 8. Power gain vs output power

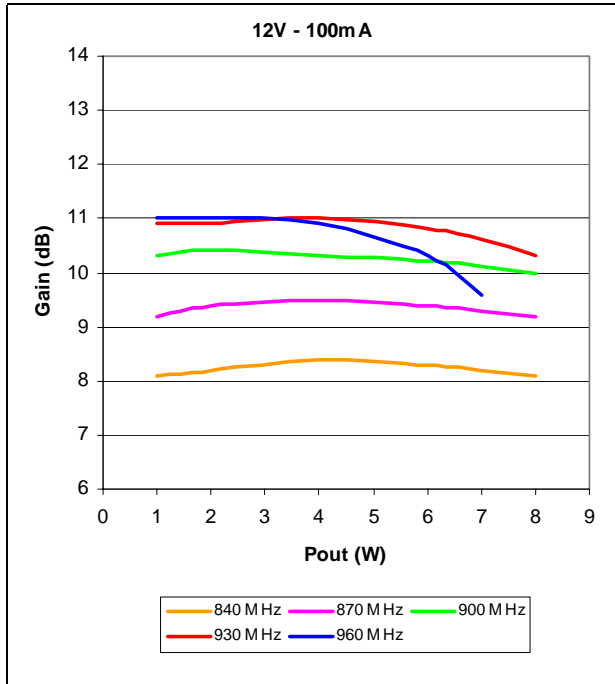
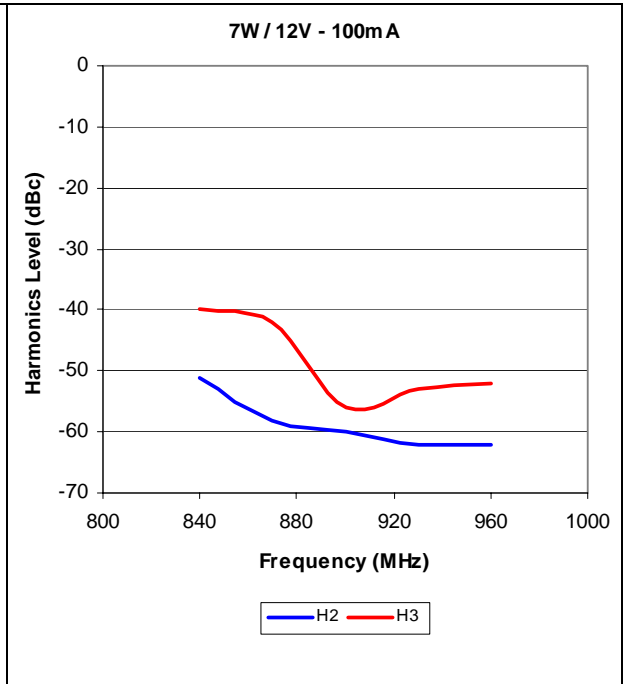

Figure 9. Harmonics vs frequency



# 5 Circuit layout

Figure 10. Circuit layout

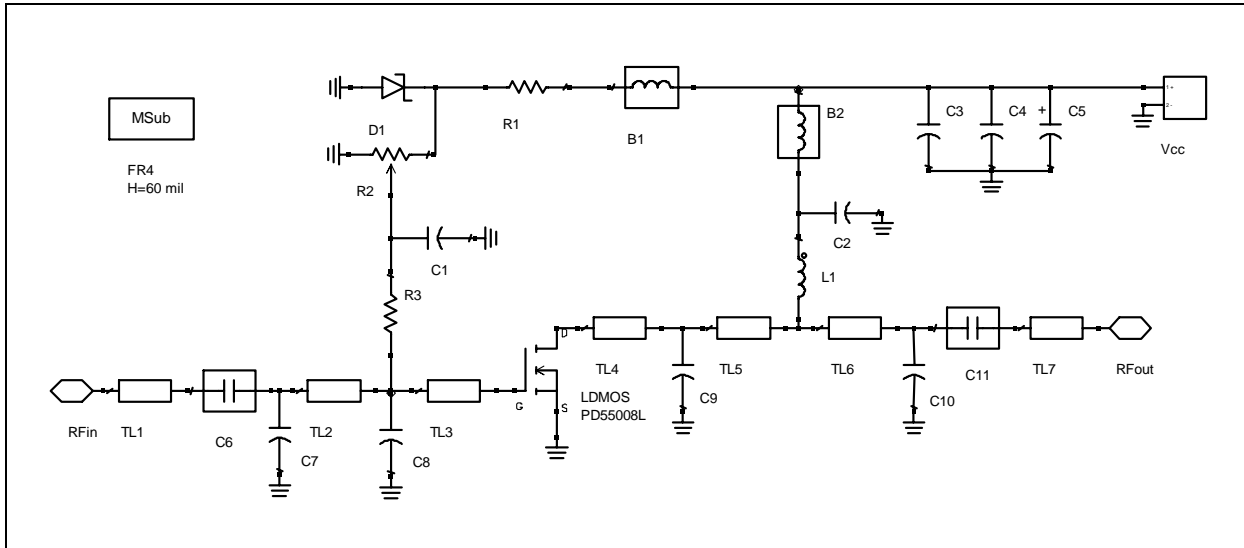

Table 5. Component part list

Component ID	Description	Value	Case size	Manufacturer	Part code
B1	Ferrite Bead			Panasonic	EXCELDRC35C
B2	Ferrite Bead			Panasonic	EXCELDRC35C
C1, C2	Capacitor	120 pF	1206	Murata	GRM42-6 COG 121J 50_
C3	Capacitor	1 nF	1206	Murata	GRM42-6 COG 102J 50
C4	Capacitor	10 nF	1206	Murata	GRM42-6_X7R 103K 50_
C5	Capacitor	10 uF	SMT	Panasonic	EEVHB1V100P
C6, C11	Capacitor	100 pF	100B	ATC	ATC 100B 101JW
C7	Capacitor	1,8 pF	100B	ATC	ATC 100B 1R8BW
C8	Capacitor	10 pF	100B	ATC	ATC 100B 100JW
C9	Capacitor	15 pF	100B	ATC	ATC 100B 150JW
C10	Capacitor	5,6 pF	100B	ATC	ATC 100B 5R6BW
D1	Zener Diode	5.1 V	SOD110	Philips	BZX284C5V1
L1	Inductor	35,5 nH		Coilcraft	B09T
R1	Resistor	1 kΩ	1206	Tyco electronics	01623440-1
R2	Potentiometer	10 kΩ		Bourns electronics	3214W-1-103E
R3	Resistor	1 kΩ	1206	Bourns electronics	01623440-1
TL1	Transmission line	W=2.87 mm	L= 7,4 mm		
TL2	Transmission line	W=2.87 mm	L= 11,2 mm		
TL3	Transmission line	W=4.98 mm	L= 4,15 mm		



Table 5. Component part list (continued)

Component ID	Description	Value	Case size	Manufacturer	Part code
TL4	Transmission line	W=4.98 mm	L= 2,5 mm		
TL5	Transmission line	W=4.98 mm	L= 2,0 mm		
TL6	Transmission line	W=2.87 mm	L= 11,6 mm		
TL7	Transmission line	W=2.87 mm	L=6,5 mm		
PD55008L-E	LDMOS			STMicroelectronics	PD55008L-E
Board	FR-4 THk=0.060" 2OZ Cu both sides				

Figure 11. Test circuit photomaster

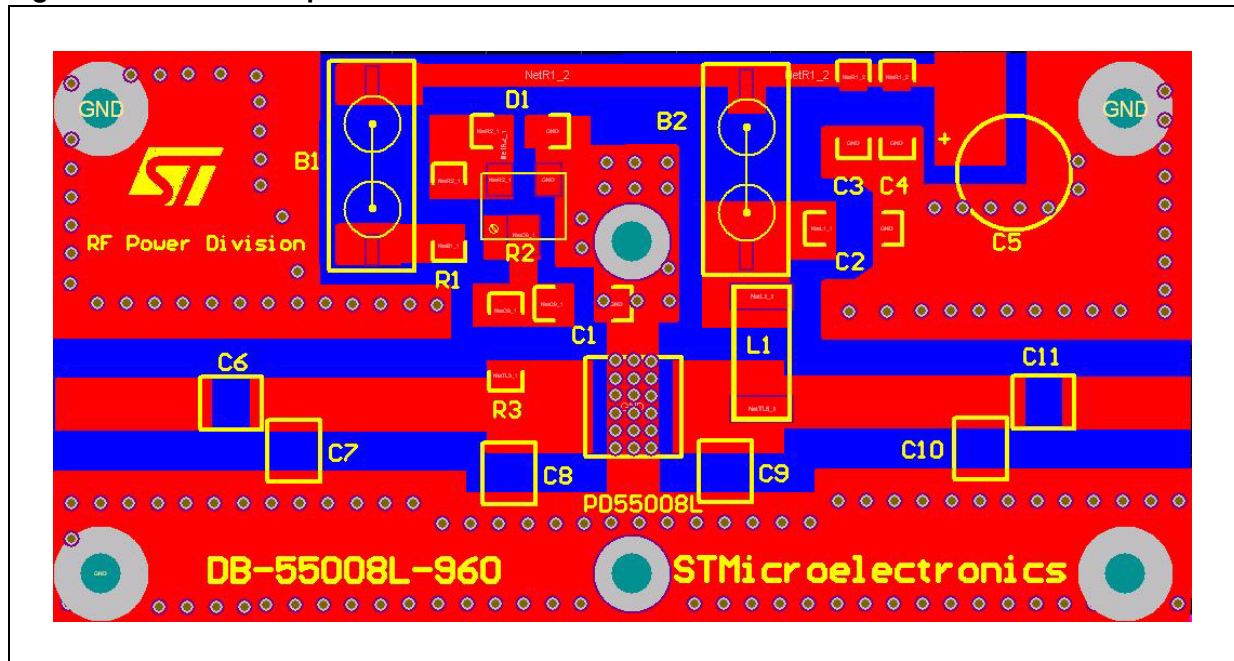

## 6 Mounting indications - PD55008L-E

Figure 12. Standard SMD mounting

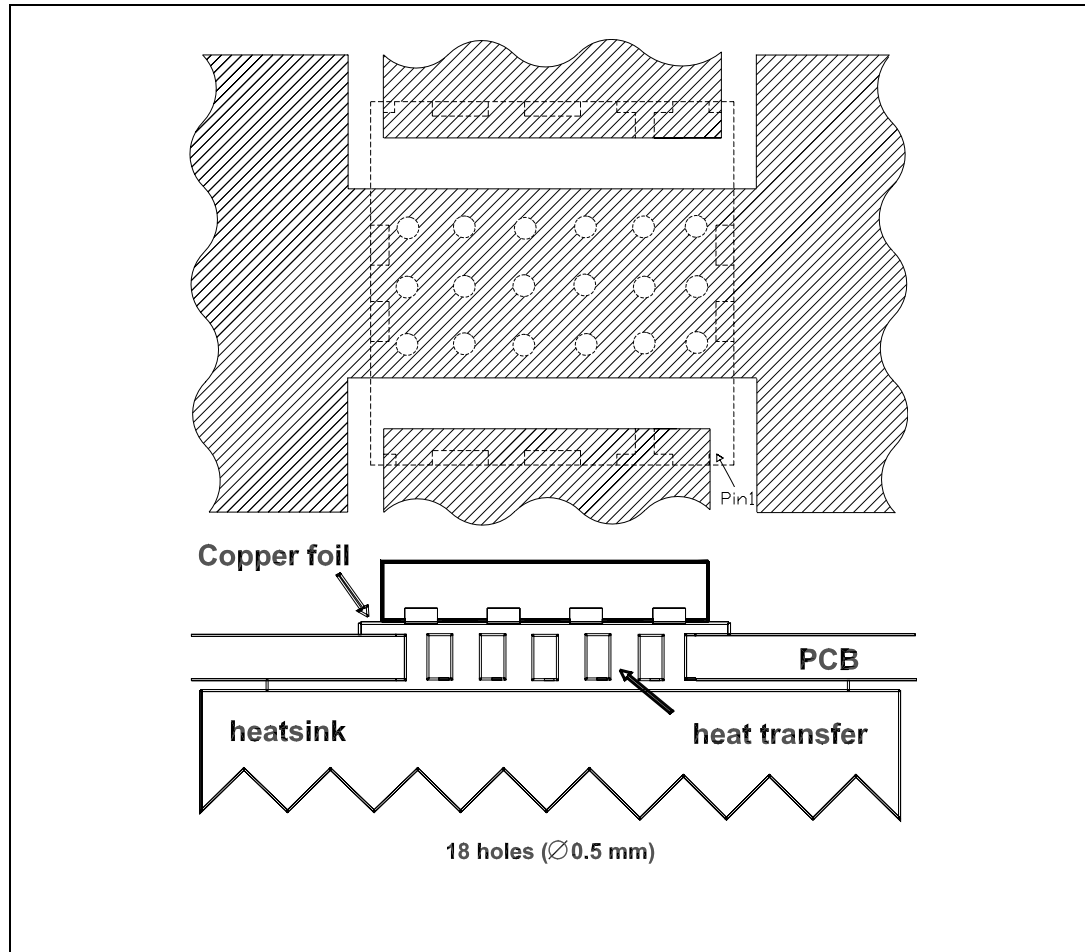

## 7 Package mechanical data - PD55008L-E

In order to meet environmental requirements, ST offers these devices in ECOPACK® packages. These packages have a Lead-free second level interconnect . The category of second level interconnect is marked on the package and on the inner box label, in compliance with JEDEC Standard JESD97. The maximum ratings related to soldering conditions are also marked on the inner box label. ECOPACK is an ST trademark. ECOPACK specifications are available at: [www.st.com](http://www.st.com)

**Table 6. PD55008L-E PowerFLAT™ mechanical data**

Dim.	mm			inch		
	Min	Typ	Max	Min	Typ	Max
A		0.90	1.00		0.035	0.039
A1		0.02	0.05		0.001	0.002
A3		0.24			0.009	
AA	0.15	0.25	0.35	0.006	0.01	0.014
b	0.43	0.51	0.58	0.017	0.020	0.023
c	0.64	0.71	0.79	0.025	0.028	0.031
D		5.00			0.197	
d		0.30			0.011	
E		5.00			0.197	
E2	2.49	2.57	2.64	0.098	0.101	0.104
e		1.27			0.050	
f		3.37			0.132	
g		0.74			0.03	
h		0.21			0.008	

**Figure 13. PowerFLAT™ package dimensions**

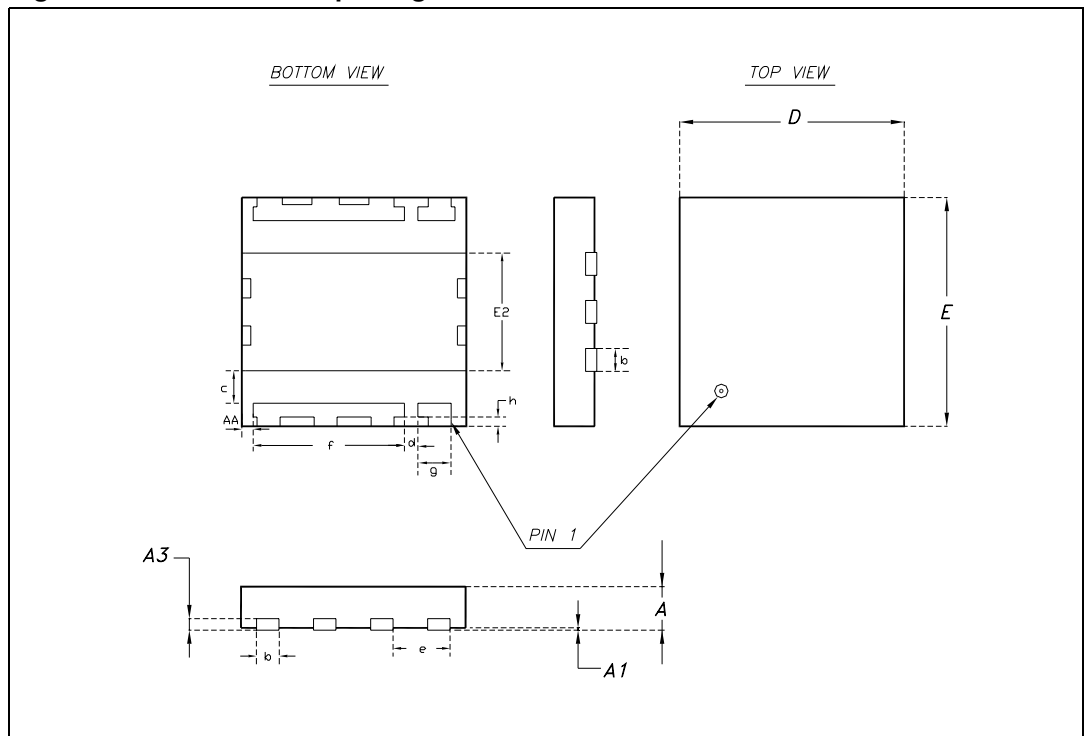

**Table 7. PD55008L-E PowerFLAT™ tape and reel dimensions**

Dim.	mm.			inch		
	Min	Typ	Max	Min	Typ	Max
Ao	5.15	5.25	5.35	0.12	0.13	0.13
Bo	5.15	5.25	5.35	0.12	0.13	0.13
Ko	1.0	1.1	1.2	0.02	0.02	0.02

**Figure 14. PowerFLAT™ tape and reel**

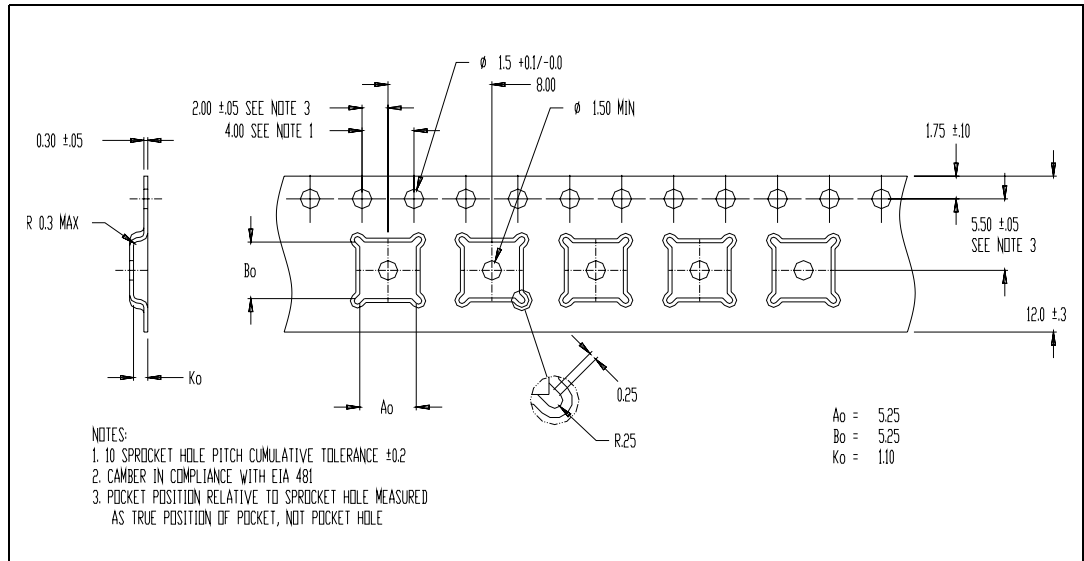

## 8 Revision history

**Table 8. Document revision history**

Date	Revision	Changes
12-Dec-2006	1	Initial release
18-Dec-2007	2	Updated: <i>Table 5 on page 8, Figure 10, Figure 11 on page 9.</i>

**Please Read Carefully:**

Information in this document is provided solely in connection with ST products. STMicroelectronics NV and its subsidiaries ("ST") reserve the right to make changes, corrections, modifications or improvements, to this document, and the products and services described herein at any time, without notice.

All ST products are sold pursuant to ST's terms and conditions of sale.

Purchasers are solely responsible for the choice, selection and use of the ST products and services described herein, and ST assumes no liability whatsoever relating to the choice, selection or use of the ST products and services described herein.

No license, express or implied, by estoppel or otherwise, to any intellectual property rights is granted under this document. If any part of this document refers to any third party products or services it shall not be deemed a license grant by ST for the use of such third party products or services, or any intellectual property contained therein or considered as a warranty covering the use in any manner whatsoever of such third party products or services or any intellectual property contained therein.

**UNLESS OTHERWISE SET FORTH IN ST'S TERMS AND CONDITIONS OF SALE ST DISCLAIMS ANY EXPRESS OR IMPLIED WARRANTY WITH RESPECT TO THE USE AND/OR SALE OF ST PRODUCTS INCLUDING WITHOUT LIMITATION IMPLIED WARRANTIES OF MERCHANTABILITY, FITNESS FOR A PARTICULAR PURPOSE (AND THEIR EQUIVALENTS UNDER THE LAWS OF ANY JURISDICTION), OR INFRINGEMENT OF ANY PATENT, COPYRIGHT OR OTHER INTELLECTUAL PROPERTY RIGHT.**

**UNLESS EXPRESSLY APPROVED IN WRITING BY AN AUTHORIZED ST REPRESENTATIVE, ST PRODUCTS ARE NOT RECOMMENDED, AUTHORIZED OR WARRANTED FOR USE IN MILITARY, AIR CRAFT, SPACE, LIFE SAVING, OR LIFE SUSTAINING APPLICATIONS, NOR IN PRODUCTS OR SYSTEMS WHERE FAILURE OR MALFUNCTION MAY RESULT IN PERSONAL INJURY, DEATH, OR SEVERE PROPERTY OR ENVIRONMENTAL DAMAGE. ST PRODUCTS WHICH ARE NOT SPECIFIED AS "AUTOMOTIVE GRADE" MAY ONLY BE USED IN AUTOMOTIVE APPLICATIONS AT USER'S OWN RISK.**

Resale of ST products with provisions different from the statements and/or technical features set forth in this document shall immediately void any warranty granted by ST for the ST product or service described herein and shall not create or extend in any manner whatsoever, any liability of ST.

ST and the ST logo are trademarks or registered trademarks of ST in various countries.

Information in this document supersedes and replaces all information previously supplied.

The ST logo is a registered trademark of STMicroelectronics. All other names are the property of their respective owners.

© 2007 STMicroelectronics - All rights reserved

STMicroelectronics group of companies

Australia - Belgium - Brazil - Canada - China - Czech Republic - Finland - France - Germany - Hong Kong - India - Israel - Italy - Japan - Malaysia - Malta - Morocco - Singapore - Spain - Sweden - Switzerland - United Kingdom - United States of America

[www.st.com](http://www.st.com)

