



## DB-54003L-470

RF POWER amplifier using 1 x PD54003L-E  
N-channel enhancement-mode lateral MOSFETs

### Features

- Excellent thermal stability
- Frequency: 400 - 470MHz
- Supply voltage: 7.5V
- Output power: 5W
- Efficiency: 57% - 61%
- Load mismatch: 20:1
- Beo free amplifier

### Description

The DB-54003L-470 is a common source N-Channel Enhancement-Mode Lateral Field Effect RF power amplifier designed for 2 Ways Comms UHF portable.

### Order code

- DB-54003L-470

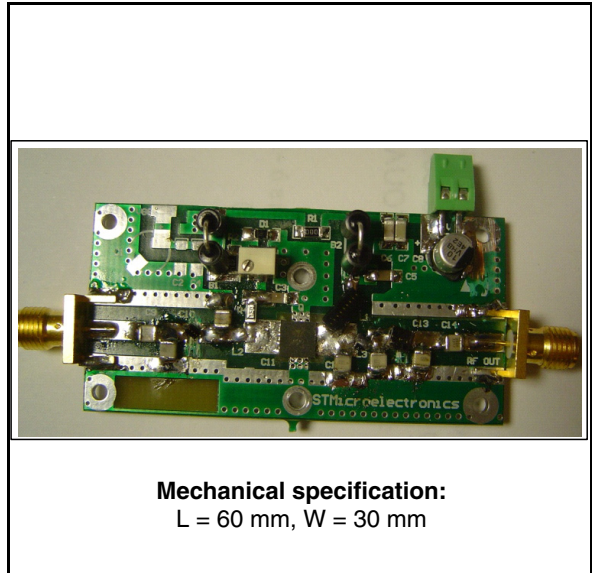

# Contents

<b>1</b>	<b>Electrical data</b> .....	<b>3</b>
	1.1 Maximum ratings .....	3
<b>2</b>	<b>Electrical characteristics</b> .....	<b>3</b>
<b>3</b>	<b>Impedance</b> .....	<b>4</b>
<b>4</b>	<b>Typical performances</b> .....	<b>5</b>
<b>5</b>	<b>Circuit layout</b> .....	<b>8</b>
<b>6</b>	<b>Mounting indications</b> .....	<b>9</b>
<b>7</b>	<b>Package mechanical data</b> .....	<b>10</b>
<b>8</b>	<b>Revision history</b> .....	<b>13</b>

# 1 Electrical data

## 1.1 Maximum ratings

Table 1. Absolute maximum ratings

Symbol	Parameter	Value	Unit
$V_{DD}$	Supply voltage	16	V
$I_D$	Drain current	1.6	A
$T_{CASE}$	Operating case temperature	-20 to +85	°C
$T_A$	Max. ambient temperature	55	°C

## 2 Electrical characteristics

$T_A = +25\text{ °C}$ ,  $V_{DD} = 7.5\text{ V}$ ,  $I_{dq} = 100\text{ mA}$

Table 2. Electrical specification

Symbol	Test conditions	Min.	Typ.	Max.	Unit
FREQ	Frequency range	400		470	MHz
$P_{OUT}$		4	5		W
Gain	@ $P_{OUT} = 5\text{ W}$	13 +/- 0.5dB			dB
ND	@ $P_{OUT} = 5\text{ W}$	57% - 61%			%
H2	2 <sup>ND</sup> Harmonic @ $P_{OUT} = 5\text{ W}$		-58	-55	dBc
H3	3 <sup>RD</sup> Harmonic @ $P_{OUT} = 5\text{ W}$		-60	-55	dBc
VSWR	Load Mismatch all phases @ $P_{OUT} = 5\text{ W}$			20:1	

### 3 Impedance

**Table 3. Impedance data**

F(MHz)	$Z_{GS}$	$Z_{DL}$
380	$2.4 + j3.6$	$3.9 + j2.1$
400	$2.5 + j4.4$	$4.4 + j2.0$
420	$2.7 + j5.1$	$4.5 + j1.6$
440	$3.2 + j5.7$	$4.1 + j1.3$
460	$3.7 + j6.0$	$3.4 + j1.3$
480	$4.0 + j5.7$	$2.8 + j1.8$
500	$3.6 + j5.0$	$2.6 + j2.4$

# 4 Typical performances

Figure 1. Output power vs input power

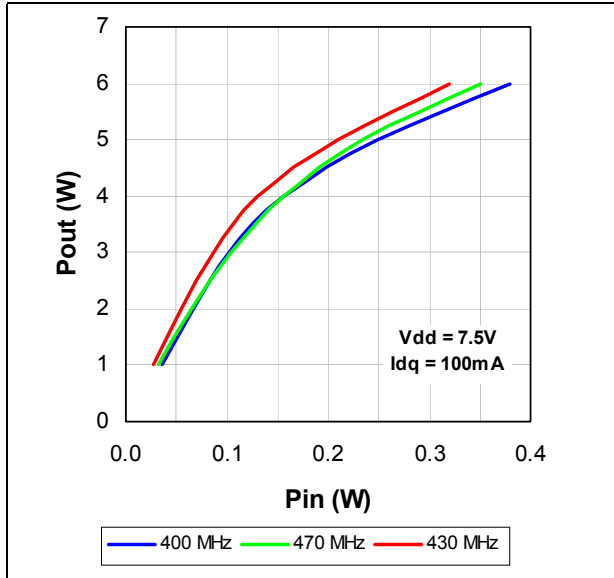

Figure 2. Gain & efficiency vs output power

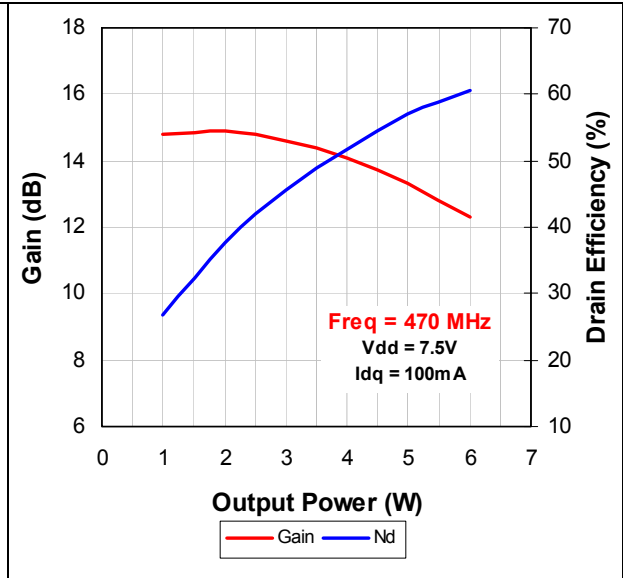

Figure 3. Gain & efficiency vs output power

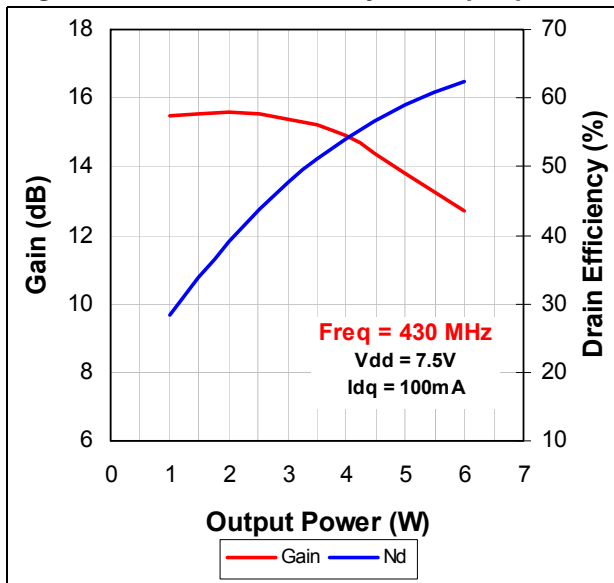

Figure 4. Gain & efficiency vs output power

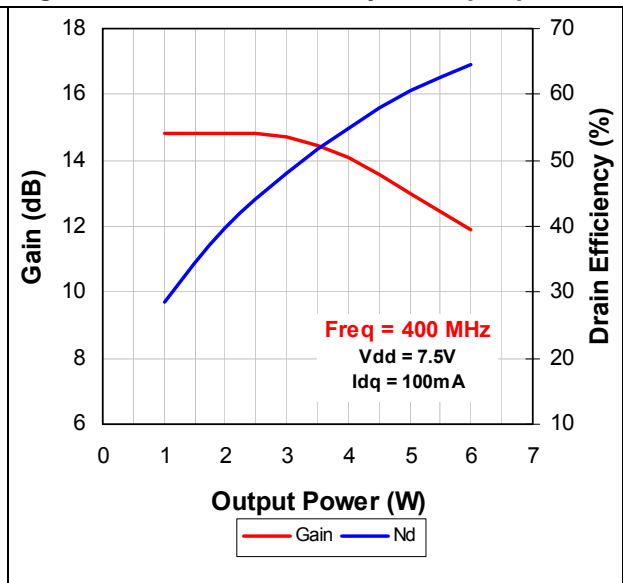

Figure 5. Power gain & efficiency vs frequency

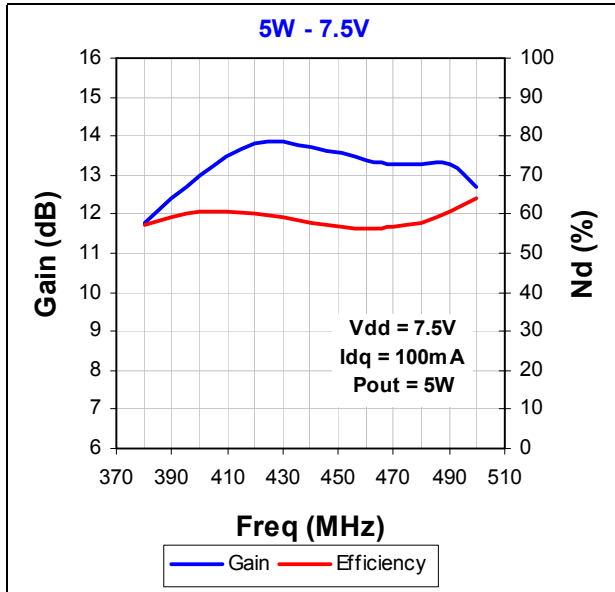

Figure 6. Power gain & efficiency vs frequency

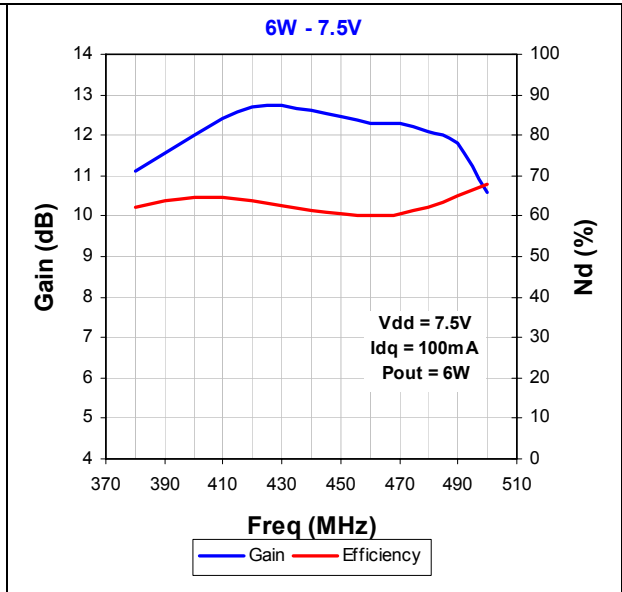

Figure 7. Input return loss vs frequency

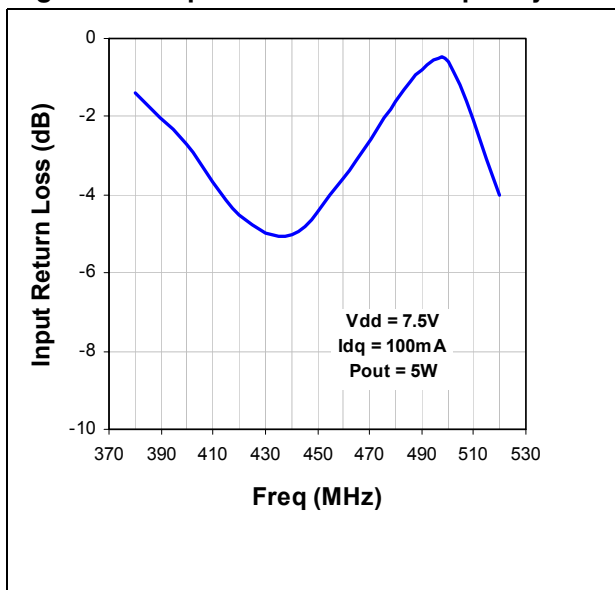

Figure 8. Harmonics vs frequency

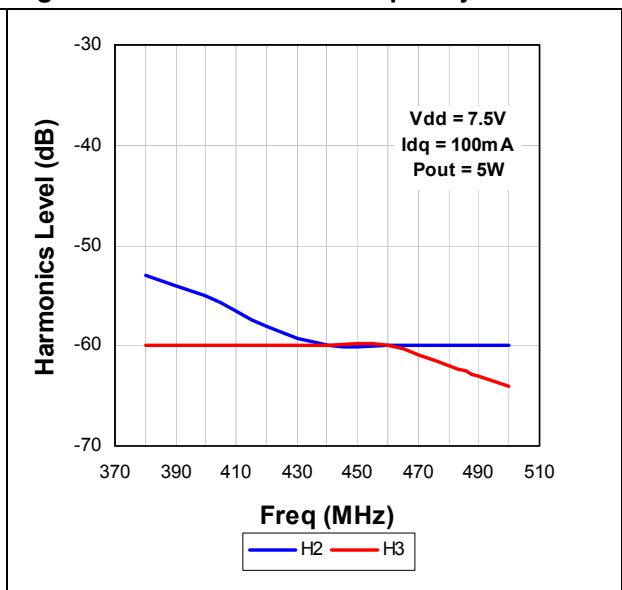
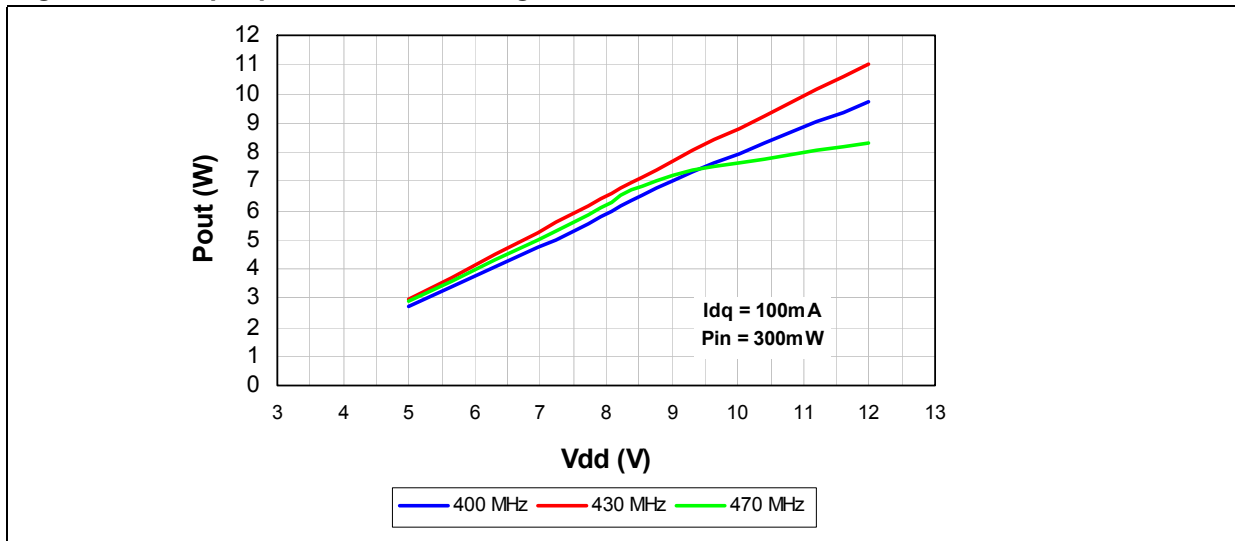
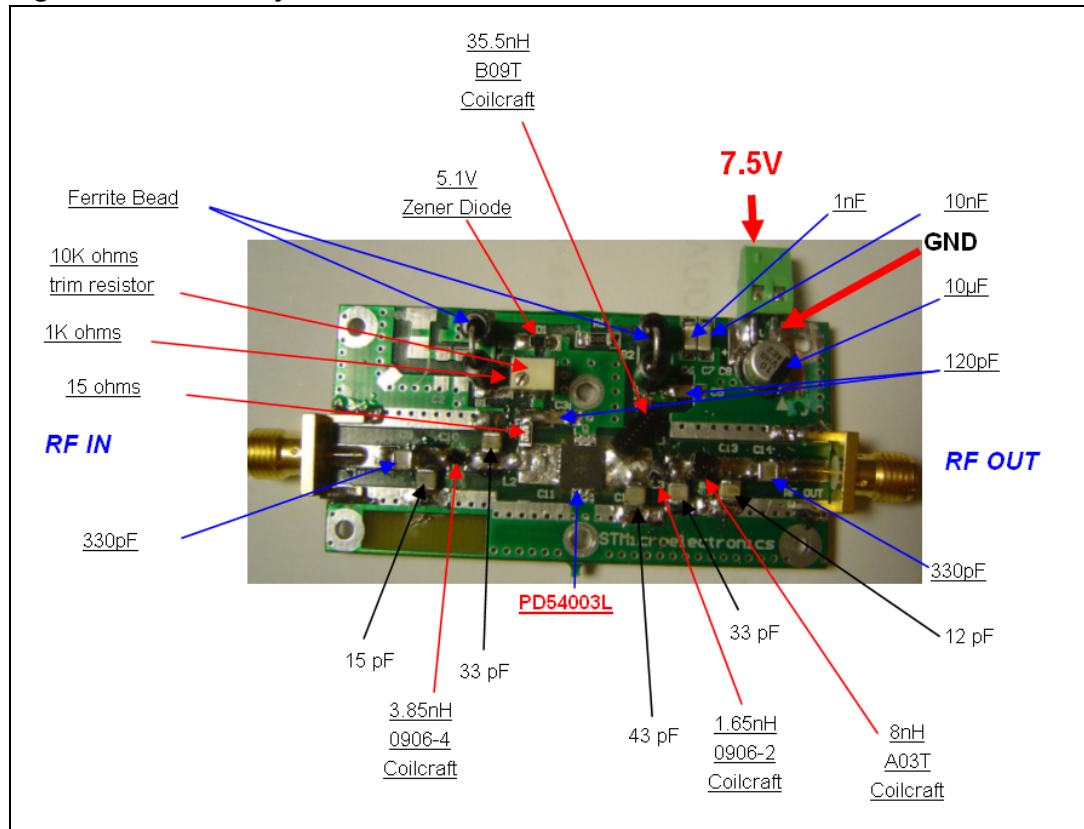

Figure 9. Output power vs drain voltage



# 5 Circuit layout

Figure 10. Circuit layout





## 6 Mounting indications

Figure 11. Standard SMD Mounting

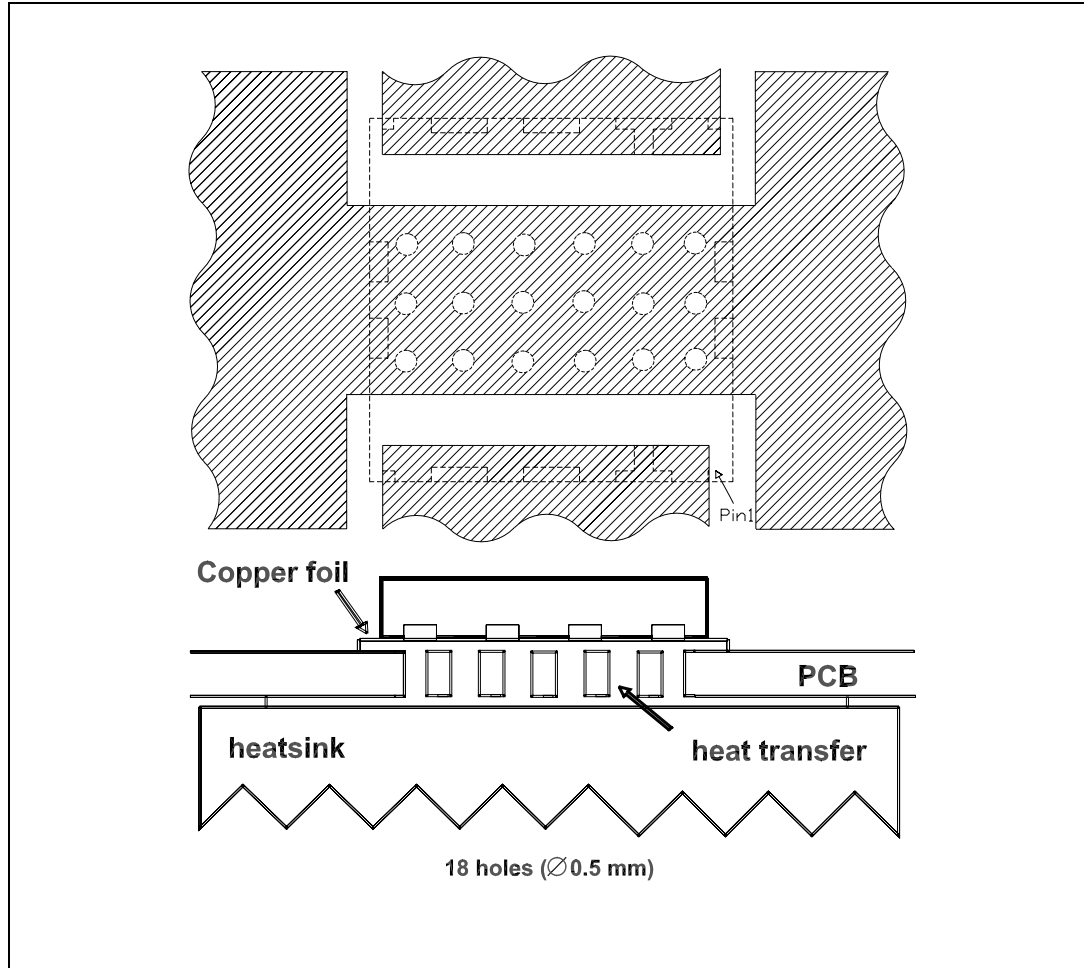

## 7 Package mechanical data

In order to meet environmental requirements, ST offers these devices in ECOPACK® packages. These packages have a Lead-free second level interconnect . The category of second level interconnect is marked on the package and on the inner box label, in compliance with JEDEC Standard JESD97. The maximum ratings related to soldering conditions are also marked on the inner box label. ECOPACK is an ST trademark. ECOPACK specifications are available at: [www.st.com](http://www.st.com)

**Table 4. PowerFLAT™ mechanical data**

Dim.	mm			inch		
	Min.	Typ.	Max.	Min.	Typ.	Max.
A		0.90	1.00		0.035	0.039
A1		0.02	0.05		0.001	0.002
A3		0.24			0.009	
AA	0.15	0.25	0.35	0.006	0.01	0.014
b	0.43	0.51	0.58	0.017	0.020	0.023
c	0.64	0.71	0.79	0.025	0.028	0.031
D		5.00			0.197	
d		0.30			0.011	
E		5.00			0.197	
E2	2.49	2.57	2.64	0.098	0.101	0.104
e		1.27			0.050	
f		3.37			0.132	
g		0.74			0.03	
h		0.21			0.008	

**Figure 12. PowerFLAT™ package dimensions**

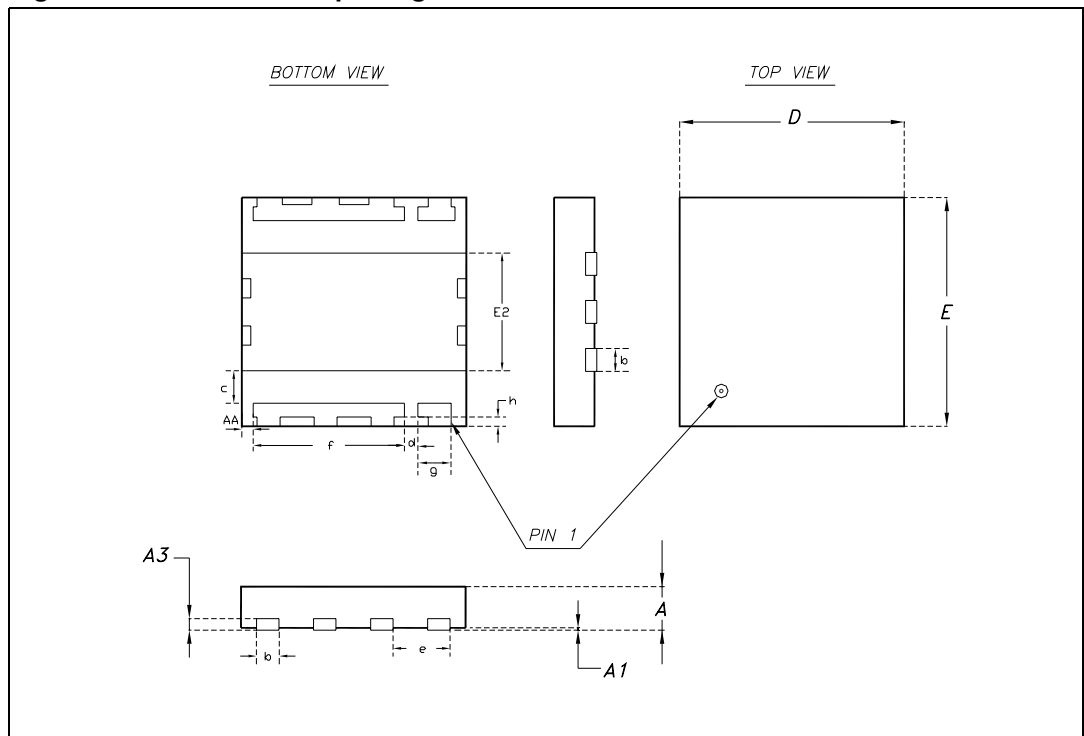

**Table 5. PowerFLAT™ tape & reel dimensions**

Dim.	mm.			inch		
	Min.	Typ	Max.	Min.	Typ	Max.
Ao	5.15	5.25	5.35	0.12	0.13	0.13
Bo	5.15	5.25	5.35	0.12	0.13	0.13
Ko	1.0	1.1	1.2	0.02	0.02	0.02

**Figure 13. PowerFLAT™ tape & reel**

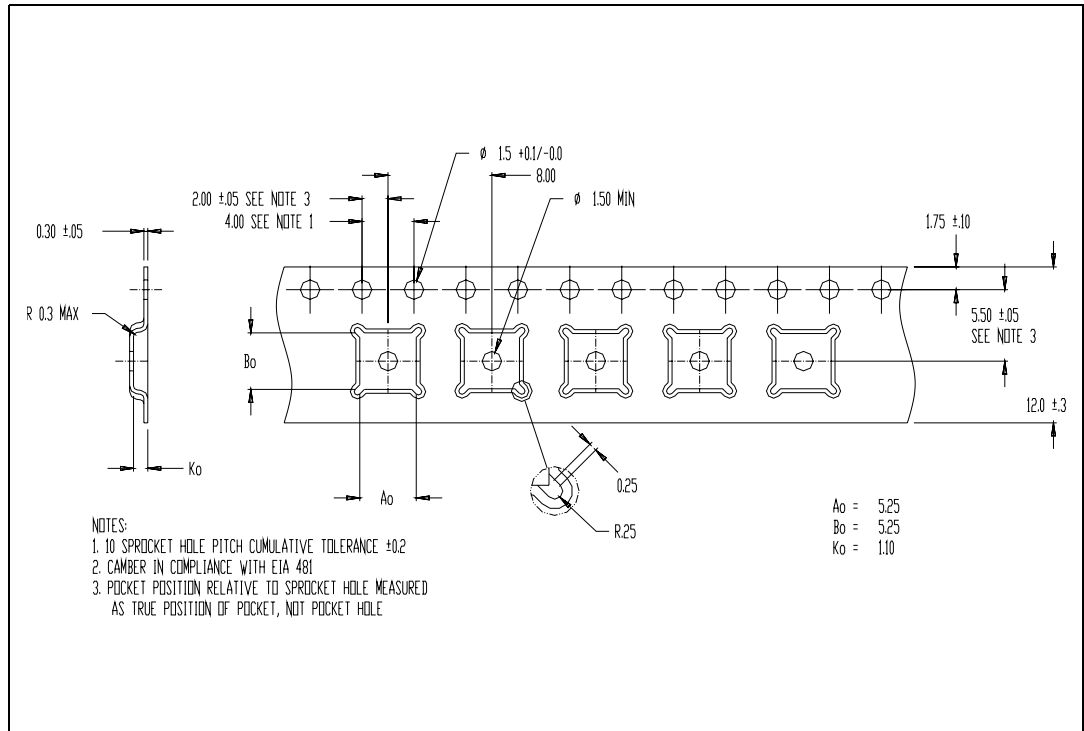

## 8 Revision history

Table 6. Revision history

Date	Revision	Changes
19-Feb-2007	1	Initial release

**Please Read Carefully:**

Information in this document is provided solely in connection with ST products. STMicroelectronics NV and its subsidiaries ("ST") reserve the right to make changes, corrections, modifications or improvements, to this document, and the products and services described herein at any time, without notice.

All ST products are sold pursuant to ST's terms and conditions of sale.

Purchasers are solely responsible for the choice, selection and use of the ST products and services described herein, and ST assumes no liability whatsoever relating to the choice, selection or use of the ST products and services described herein.

No license, express or implied, by estoppel or otherwise, to any intellectual property rights is granted under this document. If any part of this document refers to any third party products or services it shall not be deemed a license grant by ST for the use of such third party products or services, or any intellectual property contained therein or considered as a warranty covering the use in any manner whatsoever of such third party products or services or any intellectual property contained therein.

**UNLESS OTHERWISE SET FORTH IN ST'S TERMS AND CONDITIONS OF SALE ST DISCLAIMS ANY EXPRESS OR IMPLIED WARRANTY WITH RESPECT TO THE USE AND/OR SALE OF ST PRODUCTS INCLUDING WITHOUT LIMITATION IMPLIED WARRANTIES OF MERCHANTABILITY, FITNESS FOR A PARTICULAR PURPOSE (AND THEIR EQUIVALENTS UNDER THE LAWS OF ANY JURISDICTION), OR INFRINGEMENT OF ANY PATENT, COPYRIGHT OR OTHER INTELLECTUAL PROPERTY RIGHT.**

**UNLESS EXPRESSLY APPROVED IN WRITING BY AN AUTHORIZED ST REPRESENTATIVE, ST PRODUCTS ARE NOT RECOMMENDED, AUTHORIZED OR WARRANTED FOR USE IN MILITARY, AIR CRAFT, SPACE, LIFE SAVING, OR LIFE SUSTAINING APPLICATIONS, NOR IN PRODUCTS OR SYSTEMS WHERE FAILURE OR MALFUNCTION MAY RESULT IN PERSONAL INJURY, DEATH, OR SEVERE PROPERTY OR ENVIRONMENTAL DAMAGE. ST PRODUCTS WHICH ARE NOT SPECIFIED AS "AUTOMOTIVE GRADE" MAY ONLY BE USED IN AUTOMOTIVE APPLICATIONS AT USER'S OWN RISK.**

Resale of ST products with provisions different from the statements and/or technical features set forth in this document shall immediately void any warranty granted by ST for the ST product or service described herein and shall not create or extend in any manner whatsoever, any liability of ST.

ST and the ST logo are trademarks or registered trademarks of ST in various countries.

Information in this document supersedes and replaces all information previously supplied.

The ST logo is a registered trademark of STMicroelectronics. All other names are the property of their respective owners.

© 2007 STMicroelectronics - All rights reserved

STMicroelectronics group of companies

Australia - Belgium - Brazil - Canada - China - Czech Republic - Finland - France - Germany - Hong Kong - India - Israel - Italy - Japan - Malaysia - Malta - Morocco - Singapore - Spain - Sweden - Switzerland - United Kingdom - United States of America

[www.st.com](http://www.st.com)