

# AS5046

## Programmable 12-Bit 360° Magnetic Angle Encoder with Absolute 2-Wire Serial and Analog Interfaces

Data Sheet

### 1 General Description

The AS5046 is a contactless magnetic angle encoder for accurate measurement up to 360°.

It is a system-on-chip, combining integrated Hall elements, analog front end and digital signal processing in a single device.

The AS5046 provides a digital serial 12-bit as well as a programmable 10-bit ratiometric analog output that is directly proportional to the angle of a magnet, rotating over the chip.

In addition, the serial interface enables a user configurable arrangement of the Hall array and allows access to each individual Sensor of the Hall Array.

The AS5046 also provides high resolution information of the magnetic field strength, respectively the vertical distance of the magnet, thus adding excellent state-of-health information of the overall system.

An internal voltage regulator allows operation of the AS5046 from 3.3V or 5.0V supplies.

### 2 Benefits

- Complete system-on-chip
- High reliability due to non-contact sensing
- Bi-directional 2-wire interface
- Programmable ratiometric analog output
- Ideal for applications in harsh environments
- Robust system, tolerant to magnet misalignment, airgap variations, temperature variations and external magnetic fields
- No calibration required

### 3 Key Features

- 360° contactless high resolution angular position encoding
- User programmable zero position
- 12-bit 2-wire serial interface
- Versatile analog output
  - programmable angular range up to 360°
  - programmable ratiometric output voltage range
- High resolution magnet distance indication
  - 256 steps within recommended range (~0.5 to 1.8mm)
  - 256 steps over extended range (~0 to 5mm)
- Mode input for optimizing noise vs. speed
- Alignment mode for magnet placement guidance
- Wide temperature range: - 40°C to + 125°C
- Small package: SSOP16 (5.3mm x 6.2mm)

### 4 Applications

The AS5046 is ideal for applications that require high resolution, a minimum of wires between controller and sensor and where the vertical distance of the magnet is of importance:

- Remote sensors
- Rotate-and-push manual input devices
- Joysticks
- Applications with extended safety requirements regarding magnet distance

Figure 1 Typical Arrangement of AS5046 and Magnet

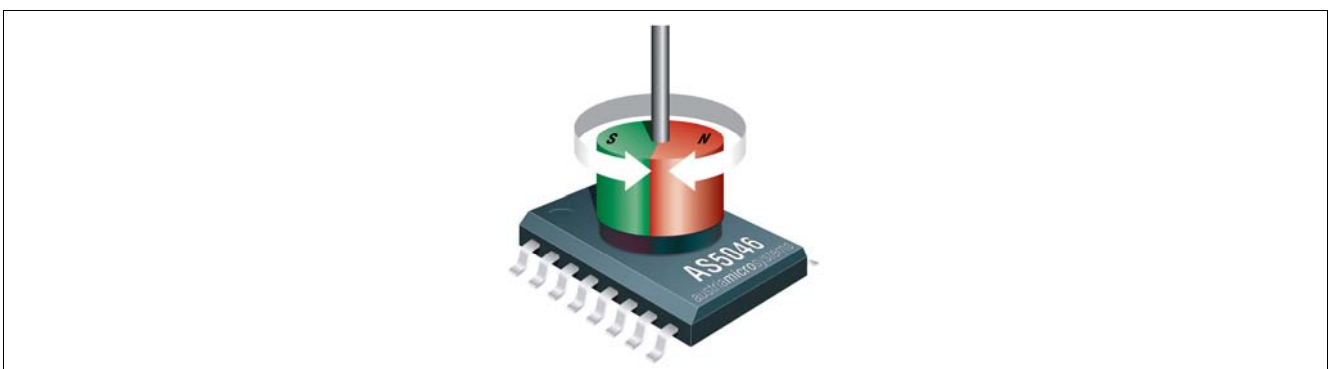
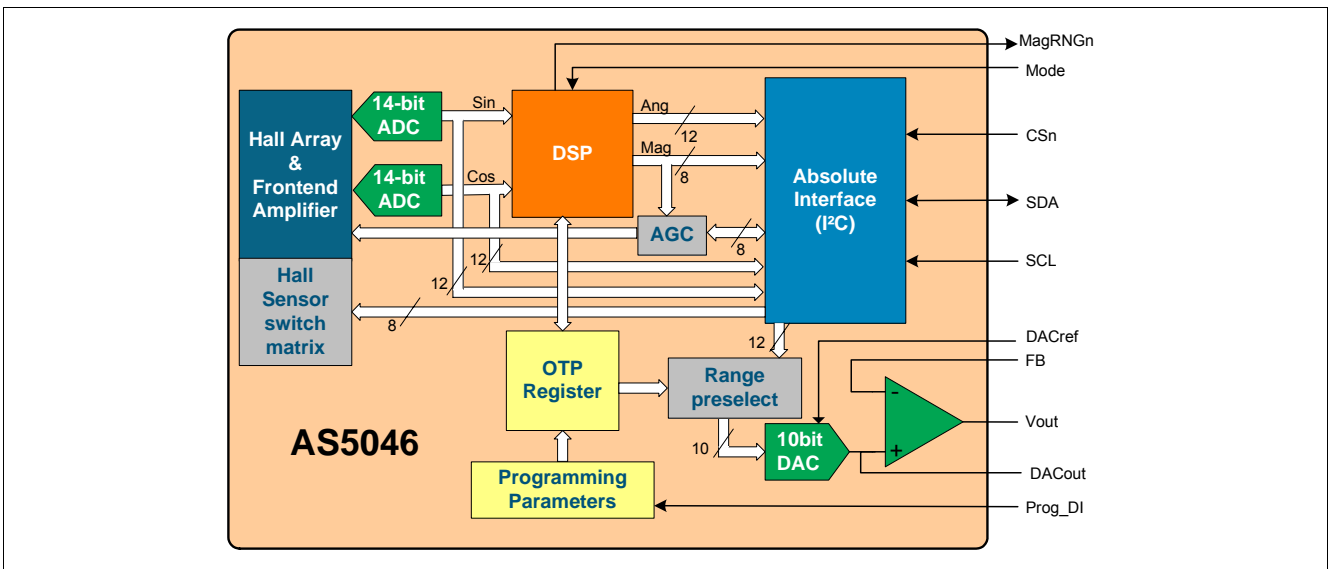

Figure 2 AS5046 Block Diagram



## 5 Table of Contents

1	General Description .....	1
2	Benefits .....	1
3	Key Features .....	1
4	Applications .....	1
5	Table of Contents .....	3
6	Pin Configuration .....	5
6.1	Pin Description .....	6
7	Electrical Characteristics .....	7
7.1	Absolute Maximum Ratings (non operating) .....	7
7.2	Operating Conditions .....	7
7.3	DC Characteristics for Digital Inputs and Outputs .....	8
7.3.1	CMOS Schmitt-Trigger Inputs: SCL, CSn (internal Pull-up), Mode (internal Pull-down) .....	8
7.3.2	CMOS Input: Program Input (Prog) .....	8
7.3.3	CMOS Output Open Drain: MagRngn .....	8
7.3.4	Tristate CMOS Output: SDA .....	8
7.3.5	Digital-to-Analog Converter .....	9
7.3.6	OPAMP Output Stage .....	9
7.4	Magnetic Input Specification .....	10
7.5	Electrical System Specifications .....	11
7.6	Timing Characteristics .....	12
7.7	Programming Conditions .....	13
8	Functional Description .....	14
9	3.3V / 5V Operation .....	14
10	Two Wire Serial Interface .....	15
10.1	Serial Interface Timing Diagrams .....	15
11	Accessible Registers for Serial Interface .....	16
11.1	Serial Interface Unit (Type ID: 0101) .....	16
11.1.1	12-bit Angle Information .....	16
11.1.2	6-bit Status Information .....	17
11.1.3	8-bit Magnitude Information .....	17
11.2	Hall Sensor Front End (Type ID: 0001) .....	17
11.3	Hall Sensor Front-End Configuration .....	18
11.4	Analog-Digital Converter Outputs, SIN/COS Signal Bus (Type ID: 0100) .....	19
11.5	Automatic Gain Control Register (Type ID: 0111) .....	19
11.6	AGC and Magnitude Registers .....	19
11.7	Z-Axis Range Indication (Push Button Feature, Red/Yellow/Green Indicator) .....	21
12	Mode Input Pin .....	22
13	Parallel Mode .....	22
14	Ratiometric Analog Angle Output .....	23
14.1	Analog Output Voltage Modes .....	23
14.1.1	Full Scale Mode .....	23
14.1.2	Diagnostic Output Mode .....	24
15	Programming the AS5046 .....	25
15.1	Zero Position Programming .....	27
15.2	Analog Mode Programming .....	27
15.2.1	Angular Range Selector .....	28
15.3	Repeated OTP Programming .....	29
15.4	Non-permanent Programming .....	29
15.5	Digital-to-Analog Converter (DAC) .....	30
15.6	OP-AMP Stage .....	30
15.6.1	Output Noise .....	30
15.7	Application Examples .....	31
16	Analog Readback Mode .....	31
17	Alignment Mode .....	32
18	Choosing the Proper Magnet .....	33
18.1	Physical Placement of the Magnet .....	34
18.1.1	Magnet Placement .....	34
19	Simulation Modelling .....	35
20	Failure Diagnostics .....	36

20.1	Magnetic Field Strength Diagnosis.....	36
20.2	Power Supply Failure Detection.....	36
21	Angular Output Tolerances.....	36
21.1	Accuracy; Digital Outputs.....	36
21.2	Accuracy; Analog Output.....	37
21.3	Transition Noise.....	38
21.4	High Speed Operation.....	38
21.4.1	Sampling Rate.....	38
21.5	Output Delays.....	39
21.5.1	Angular Error Caused by Propagation Delay.....	39
21.6	Internal Timing Tolerance.....	39
21.6.1	Absolute Output; Serial Interface.....	39
21.7	Temperature.....	39
21.7.1	Magnetic Temperature Coefficient.....	39
21.7.2	Accuracy over Temperature.....	40
21.7.3	Timing Tolerance over Temperature.....	40
22	Package Drawings and Markings.....	40
23	Packing Options.....	41
24	Recommended PCB Footprint.....	41

## 6 Pin Configuration

Figure 3 AS5046 Pin Configuration SSOP16

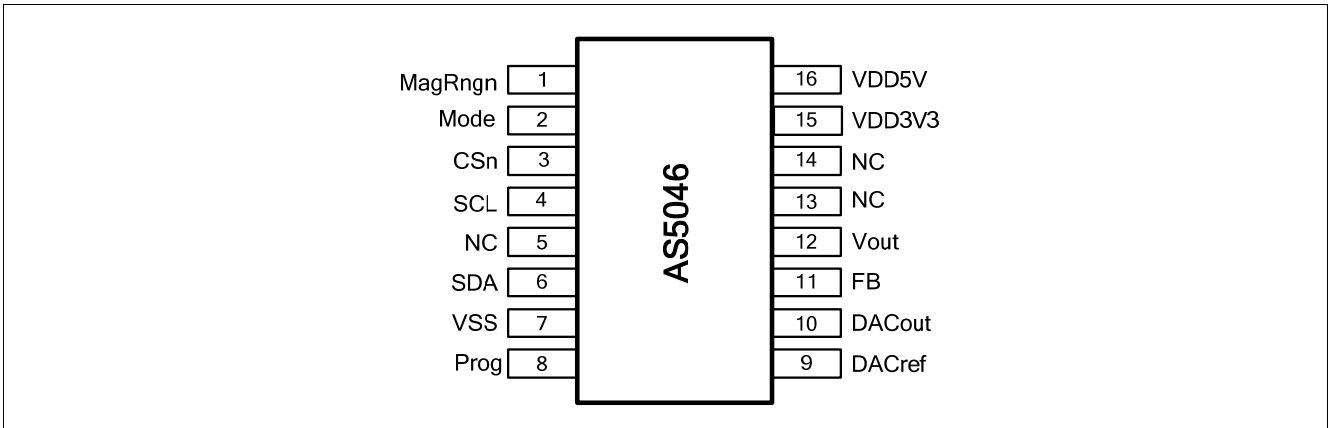

Table 1 Pin Description SSOP16 (16 lead Shrink Small Outline Package)

Pin	Symbol	Type	Description
1	MagRngn	DO_OD	Magnet Field <b>Ma</b> gnitude <b>Ra</b> NGe warning; active low, indicates that the magnetic field strength is outside of the recommended limits.
2	Mode	DI_PD, ST	<b>Mode</b> input. Select between low noise (Mode=VSS) and high speed (Mode=VDD5V) mode. Internal pull-down resistor. Must be directly connected to VSS or VDD5V.
3	CSn	DI_PU, ST	<b>Chip Select</b> , active low; Schmitt-Trigger input, internal pull-up resistor (~50kΩ). Must always be tied to VSS for normal operation.
4	SCL	DI,ST	<b>Serial Clock Line</b> .Clock input for 2-wire serial data transmission
5	NC	-	must be left unconnected
6	SDA	DIO	<b>Serial Data Line</b> . Bi-directional I/O for 2-wire serial data transmission
7	VSS	S	Negative Supply Voltage (GND)
8	Prog	DI_PD	OTP <b>Programming</b> Input. Internal pull-down resistor (~74kΩ). Should be connected to VSS if programming is not used
9	DACref	AI	<b>DAC Reference</b> voltage input for external reference
10	DACout	AO	<b>DAC output</b> (unbuffered, Ri ~8kΩ)
11	FB	AI	<b>Feedback</b> , OPAMP inverting input
12	Vout	AO	OPAMP <b>output</b>
13	NC	-	Must be left unconnected
14	NC	-	Must be left unconnected
15	VDD3V3	S	3V-Regulator Output for internal core, regulated from VDD5V.Connect to VDD5V for 3V supply voltage. Do not load externally.
16	VDD5V	S	Positive Supply Voltage, 3.0 to 5.5 V

DO\_OD digital output open drain  
 DI\_PD digital input pull-down  
 DI\_PU digital input pull-up  
 AI analog input  
 DI digital input

S supply pin  
 DO\_T digital output /tri-state  
 ST schmitt-trigger input  
 AO analog output

## 6.1 Pin Description

**Pins 7, 15 and 16** are supply pins, pins **5, 13 and 14** are for internal use and must be left open.

**Pin 1** is the magnetic field strength indicator, **MagRNGn**. It is an open-drain output that is pulled to VSS when the magnetic field is out of the recommended range (45mT to 75mT). The chip will still continue to operate, but with reduced performance, when the magnetic field is out of range. When this pin is low, the analog output at pins #10 and #12 will be 0V to indicate the out-of-range condition.

**Pin 2 MODE** allows switching between filtered (slow) and unfiltered (fast mode). This pin must be tied to VSS or VDD5V, and must not be switched after power up. See section 12.

**Pin 3 Chip Select (CSn; active low)** selects a device for serial data transmission and enables the Vout output. A “logic high” at CSn forces output SDA to digital tri-state, and force Vout to 0V.

**Pin 4 SCL** (Serial Clock) is the clock input for data transmission over the 2-wire serial interface

**Pin 6 SDA** (Serial Data Line) is the serial data input / output line during data transmission over the 2-wire interface

**Pin 8 PROG** is used to program the different operation modes, as well as the zero-position in the OTP register.

**Pin 9 DACref** is the external voltage reference input for the Digital-to-Analog Converter (DAC). If selected, the analog output voltage on pin 12 ( $V_{out}$ ) will be ratiometric to the voltage on this pin.

**Pin10 DACout** is the unbuffered output of the DAC. This pin may be used to connect an external OPAMP, etc. to the DAC.

**Pin 11 FB (Feedback)** is the inverting input of the OPAMP buffer stage.

Access to this pin allows various OPAMP configurations.

**Pin 12 Vout** is the analog output pin. The analog output is a DC voltage, ratiometric to VDD5V (3.0 – 5.5V) or an external voltage source and proportional to the angle.

## 7 Electrical Characteristics

### 7.1 Absolute Maximum Ratings (non operating)

Stresses beyond those listed under “Absolute Maximum Ratings” may cause permanent damage to the device. These are stress ratings only. Functional operation of the device at these or any other conditions beyond those indicated under “Operating Conditions” is not implied. Exposure to absolute maximum rating conditions for extended periods may affect device reliability.

Table 2 Absolute Maximum Ratings (non operating)

Parameter	Symbol	Min	Max	Unit	Note
DC supply voltage	VDD5V	-0.3	7	V	Pin VDD5V
	VDD3V3		5	V	Pin VDD3V3
Input pin voltage	V <sub>in</sub>	-0.3	VDD5V +0.3	V	Pins MagRngn, Mode, CSn, CLK, DO, DACout, FB, Vout
		-0.3	5		Pin DACref
		-0.3	7.5		Pin PROG_DI
Input current (latchup immunity)	I <sub>scr</sub>	-100	100	mA	Norm: JEDEC 78
Electrostatic discharge	ESD		± 2	kV	Norm: MIL 883 E method 3015
Storage temperature	T <sub>strg</sub>	-55	125	°C	Min – 67°F ; Max +257°F
Body temperature (Lead-free package)	T <sub>Body</sub>		260	°C	t=20 to 40s, Norm: IPC/JEDEC J-Std-020 Lead finish 100% Sn “matte tin”
Humidity non-condensing	H	5	85	%	

### 7.2 Operating Conditions

Table 3 Operating Conditions

Parameter	Symbol	Min	Typ	Max	Unit	Note
Ambient temperature	T <sub>amb</sub>	-40		125	°C	-40°F...+257°F
Supply current	I <sub>supp</sub>		16	21	mA	
Supply voltage at pin VDD5V	VDD5V	4.5	5.0	5.5	V	5V operation
Voltage regulator output voltage at pin VDD3V3	VDD3V3	3.0	3.3	3.6	V	
Supply voltage at pin VDD5V	VDD5V	3.0	3.3	3.6	V	3.3V operation (pin VDD5V and VDD3V3 connected)
Supply voltage at pin VDD3V3	VDD3V3	3.0	3.3	3.6	V	

## 7.3 DC Characteristics for Digital Inputs and Outputs

### 7.3.1 CMOS Schmitt-Trigger Inputs: SCL, CSn (internal Pull-up), Mode (internal Pull-down)

Table 4 DC Characteristics for CMOS Schmitt-Trigger Inputs: SCL, CSn (internal Pull-up), Mode (internal Pull-down)

(operating conditions:  $T_{amb} = -40$  to  $+125^{\circ}\text{C}$ ,  $V_{DD5V} = 3.0\text{-}3.6\text{V}$  (3V operation)  $V_{DD5V} = 4.5\text{-}5.5\text{V}$  (5V operation) unless otherwise noted)

Parameter	Symbol	Min	Max	Unit	Note
High level input voltage	$V_{IH}$	$0.7 * V_{DD5V}$		V	Normal operation
Low level input voltage	$V_{IL}$		$0.3 * V_{DD5V}$	V	
Schmitt Trigger hysteresis	$V_{IOn} - V_{Ioff}$	1		V	
Input leakage current	$I_{LEAK}$	-1	1	$\mu\text{A}$	Pin CLK, $V_{DD5V} = 5.0\text{V}$
Pull-up low level input current	$I_{iL}$	-30	-100		Pin CSn, $V_{DD5V} = 5.0\text{V}$
Pull-down high level input current	$I_{iH}$	30	100		Pin Mode, $V_{DD5V} = 5.0\text{V}$

### 7.3.2 CMOS Input: Program Input (Prog)

Table 5 DC Characteristics for CMOS Program Input (Prog)

(operating conditions:  $T_{amb} = -40$  to  $+125^{\circ}\text{C}$ ,  $V_{DD5V} = 3.0\text{-}3.6\text{V}$  (3V operation)  $V_{DD5V} = 4.5\text{-}5.5\text{V}$  (5V operation) unless otherwise noted)

Parameter	Symbol	Min	Max	Unit	Note
High level input voltage	$V_{IH}$	$0.7 * V_{DD5V}$	5	V	
High level input voltage	$V_{PROG}$	See Programming Conditions		V	During programming
Low level input voltage	$V_{IL}$		$0.3 * V_{DD5V}$	V	
Pull-down high level input current	$I_{iL}$		100	$\mu\text{A}$	$V_{DD5V} = 5.5\text{V}$

### 7.3.3 CMOS Output Open Drain: MagRngn

Table 6 DC Characteristics for CMOS Output Open Drain MagRngn

(operating conditions:  $T_{amb} = -40$  to  $+125^{\circ}\text{C}$ ,  $V_{DD5V} = 3.0\text{-}3.6\text{V}$  (3V operation)  $V_{DD5V} = 4.5\text{-}5.5\text{V}$  (5V operation) unless otherwise noted)

Parameter	Symbol	Min	Max	Unit	Note
Low level output voltage	$V_{OL}$		$V_{SS} + 0.4$	V	
Output current	$I_o$		4 2	mA	$V_{DD5V} = 4.5\text{V}$ $V_{DD5V} = 3\text{V}$
Open drain leakage current	$I_{oz}$		1	$\mu\text{A}$	

### 7.3.4 Tristate CMOS Output: SDA

Table 7 DC Characteristics for Tristate CMOS Output SDA

(operating conditions:  $T_{amb} = -40$  to  $+125^{\circ}\text{C}$ ,  $V_{DD5V} = 3.0\text{-}3.6\text{V}$  (3V operation)  $V_{DD5V} = 4.5\text{-}5.5\text{V}$  (5V operation) unless otherwise noted)

Parameter	Symbol	Min	Max	Unit	Note
High level output voltage	$V_{OH}$	$V_{DD5V} - 0.5$		V	
Low level output voltage	$V_{OL}$		$V_{SS} + 0.4$	V	
Output current	$I_o$		4 2	mA	$V_{DD5V} = 4.5\text{V}$ $V_{DD5V} = 3\text{V}$
Tri-state leakage current	$I_{oz}$		1	$\mu\text{A}$	



### 7.3.5 Digital-to-Analog Converter

Table 8 DC Characteristics for Digital-to-Analog Converter

Parameter	Symbol	Min	Typ	Max	Unit	Note	OTP setting
Resolution			10		bit		
Output range	$V_{OUTM1}$	0		Vref	V	0.....100% $V_{ref}$ (default)	ClampMdEn = 0 (default)
	$V_{OUTM2}$	0.10 * $V_{ref}$		0.90 * Vref	V	10.....90% $V_{ref}$	ClampMdEn = 1
Output resistance	$R_{Out,DAC}$			8	k $\Omega$	Unbuffered Pin DACout (#10)	
DAC reference voltage (DAC full scale range)	$V_{ref}$	0.2		VDD3V3-0.2	V	DAC reference = external: Pin: DACref (#9)	RefExt EN = 1
				VDD5V / 2	V	DAC reference = internal	RefExtEn = 0 (default)
Integral non-linearity	$INL_{DAC}$			+/- 1.5	LSB	Non-Linearity of DAC and OPAMP; -40....+125°C, for all analog modes: 1LSB = $V_{ref} / 1024$	
Differential non-linearity	$DNL_{DAC}$			+/- 0.5	LSB		
Analog output hysteresis	Hyst			1	LSB	All analog modes	
				2	LSB	At 360°-0° transition, 360° mode only	OR1,OR0 = 00 (default)

### 7.3.6 OPAMP Output Stage

Table 9 DC Characteristics for OPAMP Output Stage

Parameter	Symbol	Min	Typ	Max	Unit	Note
Power supply range	VDD5V	3.0		5.5	V	
Parallel load capacitance	CL			100	pF	
Parallel load resistance	RL	4.7			k $\Omega$	3.3V operation
Open loop gain	A0	92	130	144	dB	
Offset voltage RTI	VosOP	-5		5	mV	3 sigma
Output range low	VoutL			0.05 * VDD5V	V	Linear range of analog output
Output range high	VoutH	0.95 * VDD5V			V	
Current capability sink	Isink	4.8		50	mA	Permanent short circuit current: $V_{out}$ to VDD5V
current capability source	Isource	4.6		66	mA	Permanent short circuit current: $V_{out}$ to VSS
Output noise	$V_{noise}$	160	220	490	$\mu V_{rms}$	Over full temperature range; BW= 1Hz...10MHz, Gain = 2x
OPAMP gain (non-inverting)	Gain		2			Internal; OTP: FB_int EN = 1
		1		4		External OTP: FB_int EN = 0 (default); with external resistors, pins Vout [#12] and FB [#11]: see Figure 17

## 7.4 Magnetic Input Specification

Table 10 Magnetic Input Specification

(operating conditions:  $T_{amb} = -40$  to  $+125^{\circ}\text{C}$ ,  $V_{DD5V} = 3.0-3.6\text{V}$  (3V operation)  $V_{DD5V} = 4.5-5.5\text{V}$  (5V operation) unless otherwise noted)  
Two-pole cylindrical diametrically magnetised source:

Parameter	Symbol	Min	Typ	Max	Unit	Note
Diameter	$d_{mag}$	4	6		mm	Recommended magnet: $\varnothing$ 6mm x 2.5mm for cylindrical magnets
Thickness	$t_{mag}$	2.5			mm	
Magnetic input field amplitude	$B_{pk}$	45		75	mT	Required vertical component of the magnetic field strength on the die's surface, measured along a concentric circle with a radius of 1.1mm
Magnetic offset	$B_{off}$			$\pm 10$	mT	Constant magnetic stray field
Field non-linearity				5	%	Including offset gradient
Input frequency (rotational speed of magnet)	$f_{mag\_abs}$			10	Hz	Absolute mode: 600 rpm @ readout of 1024 positions (see Table 18)
	$f_{mag\_inc}$			166	Hz	Incremental mode: no missing pulses at rotational speeds of up to 10,000 rpm (see Table 18)
Displacement radius	Disp			0.25	mm	Max. offset between defined device center and magnet axis
Recommended magnet material and temperature drift			-0.12		%K	NdFeB (Neodymium Iron Boron)
			-0.035			SmCo (Samarium Cobalt)

## 7.5 Electrical System Specifications

Table 11 Electrical System Specifications

(operating conditions:  $T_{amb} = -40$  to  $+125^{\circ}\text{C}$ ,  $V_{DD5V} = 3.0$ - $3.6\text{V}$  (3V operation)  $V_{DD5V} = 4.5$ - $5.5\text{V}$  (5V operation) unless otherwise noted)

Parameter	Symbol	Min	Typ	Max	Unit	Note
Resolution <sup>1)</sup>	RES			12	bit	0.088 deg
Integral non-linearity (optimum) <sup>1)</sup>	INL <sub>opt</sub>			± 0.5	deg	Maximum error with respect to the best line fit. Verified at optimum magnet placement, $T_{amb} = 25^{\circ}\text{C}$ .
Integral non-linearity (optimum) <sup>1)</sup>	INL <sub>temp</sub>			± 0.9	deg	Maximum error with respect to the best line fit. Verified at optimum magnet placement, $T_{amb} = -40$ to $+125^{\circ}\text{C}$
Integral non-linearity <sup>1)</sup>	INL			± 1.4	deg	Best line fit = $(Err_{max} - Err_{min}) / 2$ Over displacement tolerance with 6mm diameter magnet, $T_{amb} = -40$ to $+125^{\circ}\text{C}$
Differential non-linearity <sup>1)</sup>	DNL			± 0.044	deg	12bit, no missing codes
Transition noise <sup>1)</sup>	TN			0.06	Deg RMS	1 sigma, fast mode (pin MODE = 1)
				0.03		1 sigma, slow mode (pin MODE=0 or open)
Power-on reset thresholds On voltage; 300mV typ.hysteresis Off voltage; 300mV typ.hysteresis	$V_{on}$ $V_{off}$	1.37 1.08	2.2 1.9	2.9 2.6	V V	DC supply voltage 3.3V (VDD3V3) DC supply voltage 3.3V (VDD3V3)
Power-up time; Until offset compensation finished, OCF = 1, Angular Data valid	$t_{PwrUp}$			20	ms	Fast mode (pin MODE=1)
				80		Slow mode (pin MODE=0 or open)
System propagation delay absolute output : delay of ADC and DSP	$t_{delay}$			96	$\mu\text{s}$	Fast mode (pin MODE=1)
				384		Slow mode (pin MODE=0 or open)
Internal sampling rate for absolute output	$f_{S,mode0}$	2.48	2.61	2.74	kHz	$T_{amb} = 25^{\circ}\text{C}$ , slow mode (pin MODE=0 or open)
		2.35	2.61	2.87		$T_{amb} = -40$ to $+125^{\circ}\text{C}$ , slow mode (pin MODE=0 or open)
Internal sampling rate for absolute output	$f_{S,mode1}$	9.90	10.42	10.94	kHz	$T_{amb} = 25^{\circ}\text{C}$ , fast mode (pin MODE=1)
		9.38	10.42	11.46		$T_{amb} = -40$ to $+125^{\circ}\text{C}$ , : fast mode (pin MODE=1)
Read-out frequency	CLK	>0		1	MHz	Max. clock frequency to read out serial data

Note: 1) Digital interface

Figure 4 Integral and Differential Non-Linearity (exaggerated curve)

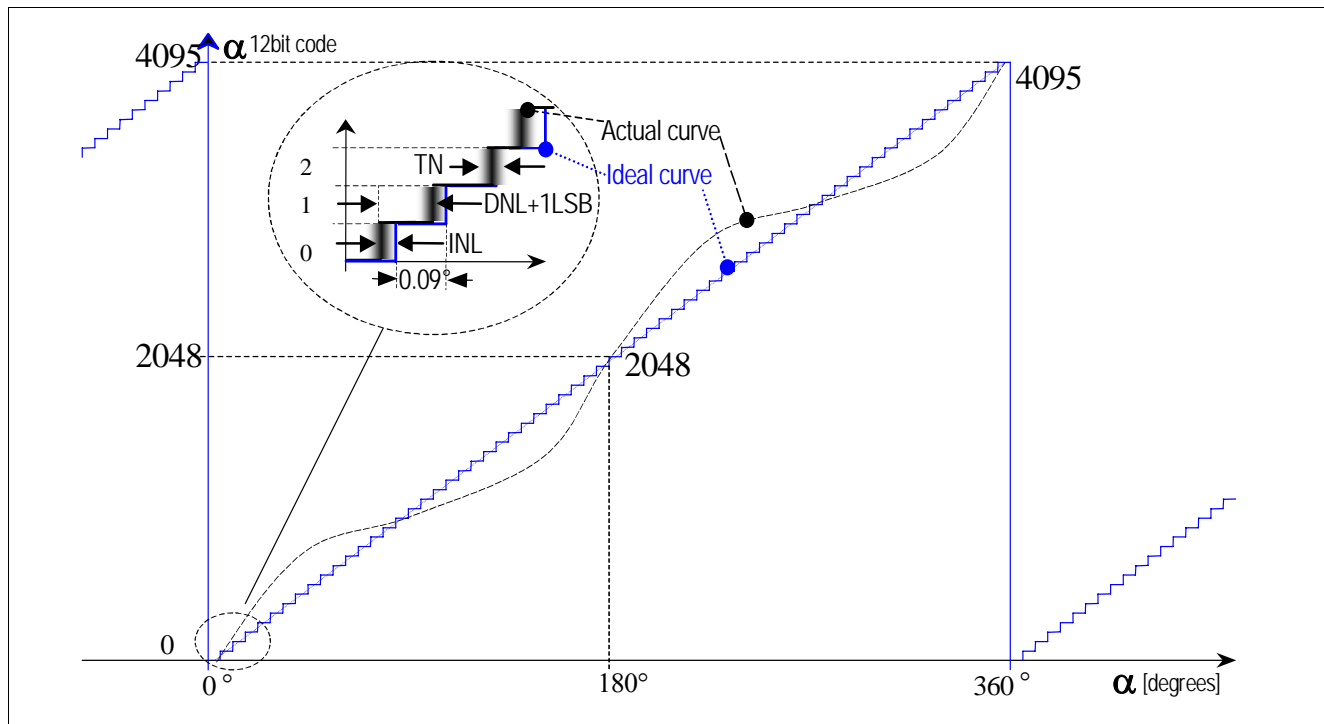

Integral Non-Linearity (INL) is the maximum deviation between actual position and indicated position.  
 Differential Non-Linearity (DNL) is the maximum deviation of the step length from one position to the next.  
 Transition Noise (TN) is the repeatability of an indicated position.

## 7.6 Timing Characteristics

Table 12 Timing Characteristics – 2-Wire Serial Interface

(operating conditions:  $T_{amb} = -40$  to  $+125^{\circ}\text{C}$ ,  $V_{DD5V} = 3.0\text{-}3.6\text{V}$  (3V operation)  $V_{DD5V} = 4.5\text{-}5.5\text{V}$  (5V operation) unless otherwise noted)

Parameter	Symbol	Min	Typ	Max	Unit	Note
Data output activated (logic high)	$t_{DO\ active}$			100	ns	Time between falling edge of CSn and data output activated
First data shifted to output register	$t_{CLK\ FE}$	500			ns	Time between falling edge of CSn and first falling edge of CLK
Start of data output	$T_{CLK / 2}$	500			ns	Rising edge of CLK shifts out one bit at a time
Data output valid	$t_{DO\ valid}$			413	ns	Time between rising edge of CLK and data output valid
Data output tristate	$t_{DO\ tristate}$			100	ns	After the last bit DO changes back to "tristate"
Pulse width of CSn	$t_{CSn}$	500			ns	CSn = high; To initiate read-out of next angular position
Read-out frequency	$f_{CLK}$	>0		1	MHz	Clock frequency to read out serial data

## 7.7 Programming Conditions

Table 13 Programming Conditions

(operating conditions:  $T_{amb} = -40$  to  $+125^{\circ}\text{C}$ ,  $V_{DD5V} = 3.0-3.6\text{V}$  (3V operation)  $V_{DD5V} = 4.5-5.5\text{V}$  (5V operation) unless otherwise noted)

Parameter	Symbol	Min	Typ	Max	Unit	Note
Programming enable time	$t_{\text{Prog enable}}$	2			$\mu\text{s}$	Time between rising edge at Prog pin and rising edge of CSn
Write data start	$t_{\text{Data in}}$	2			$\mu\text{s}$	
Write data valid	$t_{\text{Data in valid}}$	250			ns	Write data at the rising edge of $\text{CLK}_{\text{PROG}}$
Load programming data	$t_{\text{Load PROG}}$	3			$\mu\text{s}$	
Rise time of $V_{\text{PROG}}$ before $\text{CLK}_{\text{PROG}}$	$t_{\text{PrgR}}$	0			$\mu\text{s}$	
Hold time of $V_{\text{PROG}}$ after $\text{CLK}_{\text{PROG}}$	$t_{\text{PrgH}}$	0		5	$\mu\text{s}$	
Write data – programming $\text{CLK}_{\text{PROG}}$	$\text{CLK}_{\text{PROG}}$			250	kHz	
CLK pulse width	$t_{\text{PROG}}$	1.8	2	2.2	$\mu\text{s}$	During programming; 16 clock cycles
Hold time of $V_{\text{PROG}}$ after programming	$t_{\text{PROG finished}}$	2			$\mu\text{s}$	Programmed data is available after next power-on
Programming voltage	$V_{\text{PROG}}$	7.3	7.4	7.5	V	Must be switched off after zapping
Programming voltage off level	$V_{\text{ProgOff}}$	0		1	V	Line must be discharged to this level
Programming current	$I_{\text{PROG}}$			130	mA	During programming
Analog read CLK	$\text{CLK}_{\text{Aread}}$			100	kHz	Analog readback mode
Programmed zener voltage (log. 1)	$V_{\text{programmed}}$			100	mV	$V_{\text{Ref}} - V_{\text{PROG}}$ during analog readback mode (see chapter <i>Analog Readback Mode</i> )
Unprogrammed zener voltage (log. 0)	$V_{\text{unprogrammed}}$	1			V	

## 8 Functional Description

The AS5046 is manufactured in a CMOS standard process and uses a spinning current Hall technology for sensing the magnetic field distribution across the surface of the chip.

The integrated Hall elements are placed in a circle around the center of the device and deliver a voltage representation of the magnetic field perpendicular to the surface of the IC.

Through Sigma-Delta Analog / Digital Conversion and Digital Signal-Processing (DSP) algorithms, the AS5046 provides accurate high-resolution absolute angular position information. For this purpose a Coordinate Rotation Digital Computer (CORDIC) calculates the angle and the magnitude of the Hall array signals.

The DSP is also used indicate movements of the magnet towards or away from the chip and to indicate, when the magnetic field is outside of the recommended range (status bits = MagInc, MagDec; hardware pin = MagRngn). In addition, two 8-bit registers are available that allow determination of the magnetic field strength over a wide range.

A small low cost diametrically magnetized (two-pole) standard magnet, centered over the chip, is used as the input device.

The AS5046 senses the orientation of the magnetic field and calculates a 12-bit binary code. This code can be accessed via a bi-directional serial two-wire interface. In addition to the digital output, the absolute angle is converted into a 1024-step (10-bit) analog signal, ratiometric to the supply voltage.

The analog output can be configured in many ways, such as 360°/180°/90° or 45° angular range, external or internal DAC reference voltage, 0-100%\*VDD or 10-90% \*VDD analog output range, external or internal amplifier gain setting. The various output modes as well as a user programmable zero position can be programmed in an OTP register. As long as no programming voltage is applied to pin PROG, the new setting may be overwritten at any time and will be reset to default when power is cycled. To make the setting permanent, the OTP register must be programmed by applying a programming voltage.

The AS5046 is tolerant to magnet misalignment and unwanted external magnetic fields due to differential measurement technique and Hall sensor conditioning circuitry.

It is also tolerant to airgap and temperature variations due to Sin-/Cos- signal evaluation.

## 9 3.3V / 5V Operation

Figure 5 Connections for 5V / 3.3V Supply Voltages

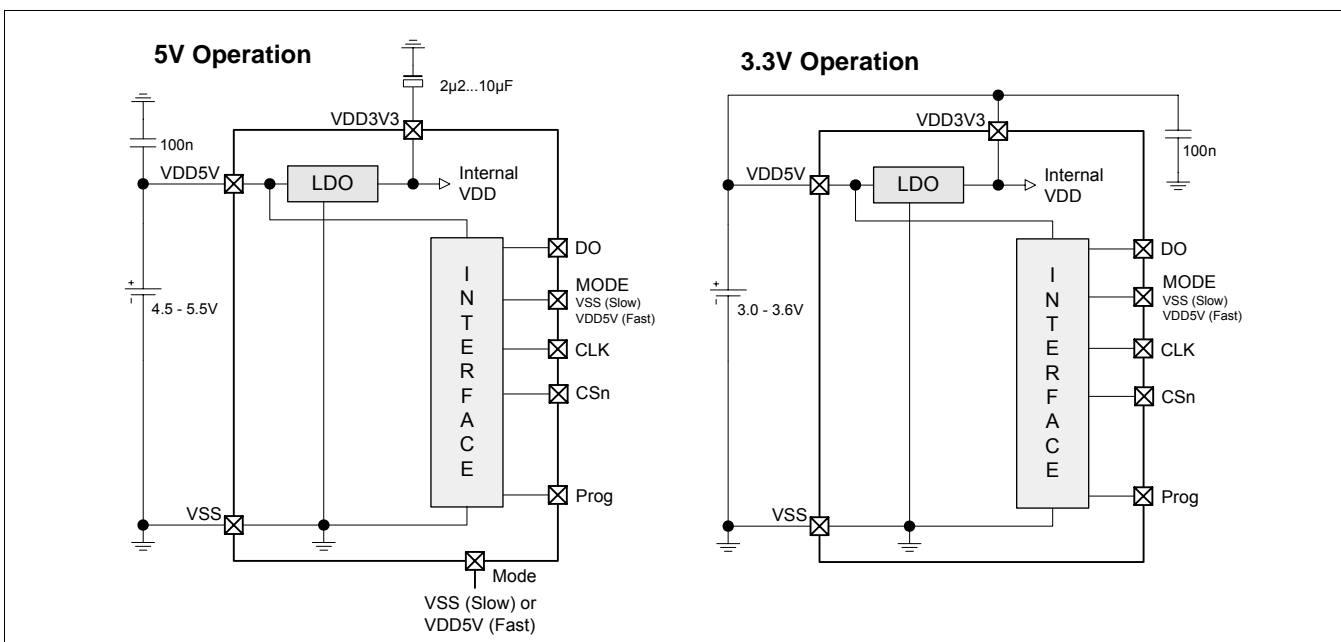

The AS5046 operates either at 3.3V  $\pm$ 10% or at 5V  $\pm$ 10%. This is made possible by an internal 3.3V Low-Dropout (LDO) Voltage regulator. The core supply voltage is always taken from the LDO output, as the internal blocks are always operating at 3.3V. For 3.3V operation, the LDO must be bypassed by connecting VDD3V3 with VDD5V (see Figure 5).

For 5V operation, the 5V supply is connected to pin VDD5V, while VDD3V3 (LDO output) must be buffered by a 2.2...10µF capacitor, which should be placed close to the supply pin (see Figure 5).

The VDD3V3 output is intended for internal use only. It should not be loaded with an external load.

The voltage levels of the digital interface I/O's correspond to the voltage at pin VDD5V, as the I/O buffers are supplied from this pin (see Figure 5).

A buffer capacitor of 100nF is recommended in both cases close to pin VDD5V. Note that pin VDD3V3 must always be buffered by a capacitor. It must not be left floating, as this may cause an unstable internal 3.3V supply voltage which may lead to larger than normal jitter of the measured angle.

## 10 Two Wire Serial Interface

The AS5046 is accessible via a bi-directional serial interface.

CSn must always be tied to VSS during serial data transmission.

### 10.1 Serial Interface Timing Diagrams

The registers in the AS5046 are available in a data length of 8 bit (1 byte), 24 bit (3 bytes) and 32 bit (4 bytes). Shown below in Figure 6 is a common 8-bit data transfer.

Figure 6 8-bit Serial Read / Write Timing

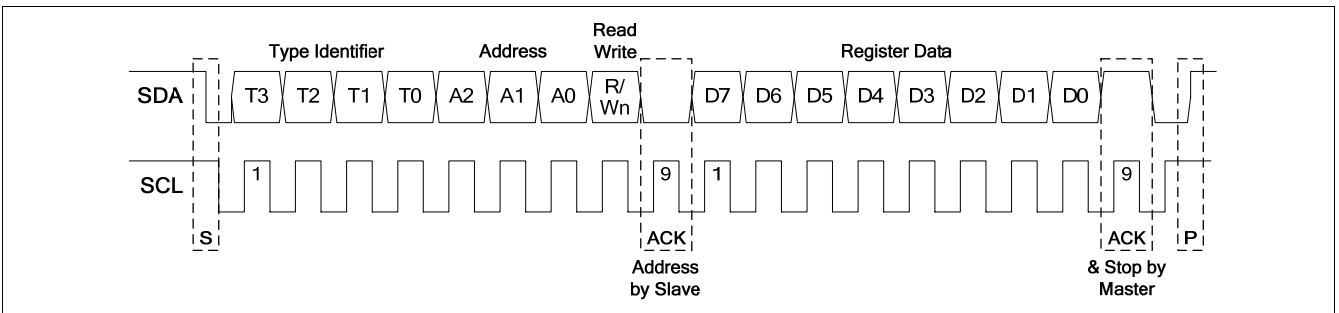
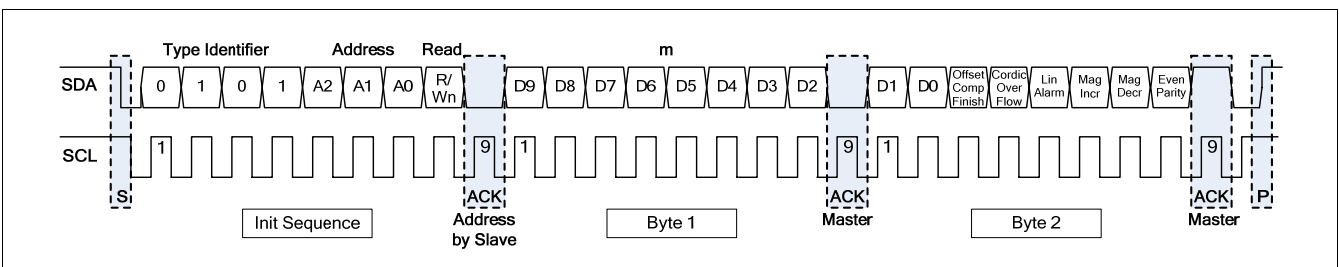

Figure 7 shows a transfer timing diagram for the first 16 bits of the Serial Interface Unit.

Figure 7 16-bit Serial Read / Write Timing



## 11 Accessible Registers for Serial Interface

Table 14 Serial Register Overview

Status Register	Internal Type Identifier	Internal Address		Register Bit Count	Read / Write	Note
Serial Interface Unit	0101	000	Programmable with A2...A0 <sup>1)</sup>	32	Read only	10 bit angle <upper 10bits: D11:D2>
						6 bit status
						8 bit magnitude
						2 bit angle <lower 2 bits: D1:D0>
Hall Sensor Front End	0001	000 -111	Fixed address range	8	Read / Write	8 selectable Hall front-end status registers
ADC outputs, SIN/COS signal bus	0100	000	Fixed address	24	Read / Write <sup>2)</sup>	12bit SIN , 12bit COS input
Automatic Gain Control	0111	000	Fixed address	8	Read / Write <sup>3)</sup>	AGC Counter

Notes:

- 1) This address is also modified with the analog mode setting
- 2) Writing a value to any of the SIN- COS- registers halts the conversion loop and calculates an angle that is given by the values in the SIN and COS registers. A Read command from these registers restarts the automatic conversion loop.
- 3) Writing a value to the AGC counter register halts the automatic gain control loop and sets the AGC to the value written in this register. The angle conversion loop continues to operate. A Read command from the AGC register restarts the automatic gain control loop.

### 11.1 Serial Interface Unit (Type ID: 0101)

The Serial Interface Unit contains 32 bits of data:

T.I. 0101	Byte 1								Byte 2								Byte 3								Byte 4							
Addr. 000...111	D11	D10	D9	D8	D7	D6	D5	D4	D3	D2	OCF	COF	LIN	M_I	M_D	P	M7	M6	M5	M4	M3	M2	M1	M0	D1	D0	0	0	0	0	0	0
	Angle								6 bit status								8 bit magnitude (MSB first)								Angle							

Note that the angle information is only valid, if the Hall Sensor Front-end is configured properly. See *Table 16* for more information.

#### 11.1.1 12-bit Angle Information

The 12-bit angle data consists of two blocks: the upper 10-bits in bytes 1 & 2 and the lower two bits in byte 4.



### 11.1.2 6-bit Status Information

Table 15 Status Bits of Byte 2 of the SIU

Status bit 1	SIU bit 11	Offset Comp Finish	OCF	must be 1 for valid data
Status bit 2	SIU bit 12	CORDIC Over Flow	COF	must be 0; if this bit is set, the angular data is invalid
Status bit 3	SIU bit 13	Lin Alarm	LIN	LINearity warning bit. Should be 0 for normal operation. Will be 1 when the magnetic field is too high or too low
Status bit 4	SIU bit 14	Mag Incr.	M_I	This bit is set temporarily when the magnetic field increases, when the magnet is pushed towards the IC
Status bit 5	SIU bit 15	Mag Decr.	M_D	This bit is set temporarily when the magnetic field decreases, when the magnet is pulled away from the IC
Status bit 6	SIU bit 16	Even Parity	P	Even parity check bit of bytes 1 & 2

### 11.1.3 8-bit Magnitude Information

The magnitude information is a value that is proportional to the magnetic field strength. A strong magnet (or close distance between magnet and chip) will result in a high magnitude value and vice versa. When the automatic gain control (AGC) is active (default state), it tries to keep the magnitude value stable at a value of  $3F_H$ .

## 11.2 Hall Sensor Front End (Type ID: 0001)

The Hall Sensor Front End allows configuration of each Hall Sensor. Each sensor can be disabled or connected to either the SIN or COS signal bus. Additionally, each sensor can be inverted for differential measurement. Each Hall Sensor is selected through a device address for the type identifier 0001,

- address 000 selects Hall Sensor H0 (see Figure 8)
- address 111 selects Hall Sensor H7 (see Figure 8)

Figure 8 Location of Hall Elements on Chip (top view)

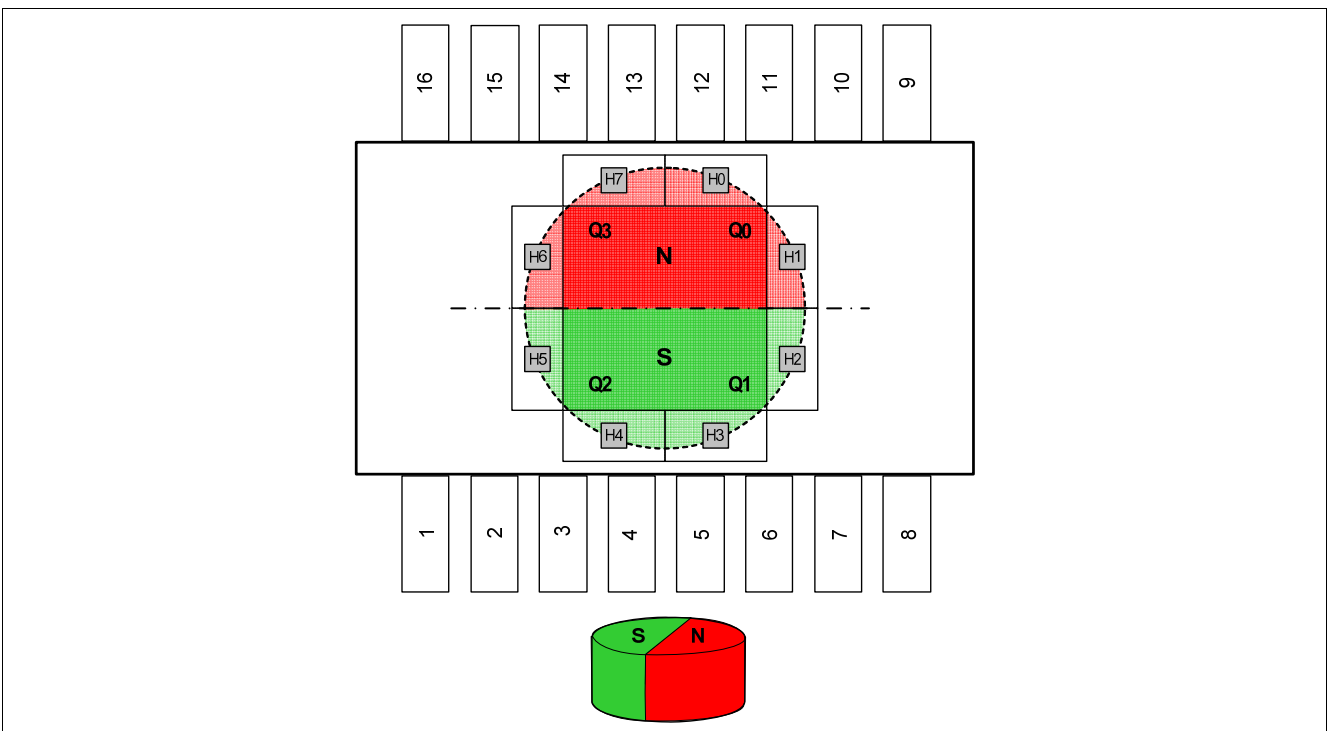

Note: If the magnet is placed like shown in Figure 8 the encoder reading will be of zero.

For each Hall Sensor, the corresponding Front End contains 8 bits

Type ID: 0001	Byte1							
Addr. 000...111	TestEN	SenseEN	NC	NC	COS_EN	SIN_EN	INV	PD

- TestEN: always set to 0
- SenseEN: set to 1 for enabled Hall Elements, set to 0 for disabled Hall Elements
- COS\_EN: set to 0 for disabled Hall Elements, set to 1 if this Hall Element should be added to the COS signal bus. It is also possible to enable multiple Hall sensors to this bus
- SIN\_EN: set to 0 for disabled Hall Elements, set to 1 if this Hall Element should be added to the SIN signal bus. It is also possible to enable multiple Hall sensors to this bus
- INV: set to 1 if the Hall Element should be inverted for differential measurement. Set to 0 if the Hall Element should not be inverted
- PD: set to 0 for normal operation, set to 1 if the Hall Sensor should be powered down.

Note: When enabling or disabling individual Hall elements to the SIN- and COS- signal buses it is recommended to allow several milliseconds (typ. 5ms) of dwelling time until the signal is stable and eventual offsets are compensated.

### 11.3 Hall Sensor Front-End Configuration

The default configuration for the Hall Sensor Front-End is set for angle measurement. This configuration must always be programmed when an angle should be measured and read from the Serial Interface Unit register.

Table 16 Hall Sensor Front-End Default Configuration

	Addr	testEN	SenseEN	NC	NC	COS_EN	SIN_EN	Inv	PD
FE0	000	0	1	0	0	0	1	0	0
FE1	001	0	1	0	0	0	1	0	0
FE2	010	0	1	0	0	1	0	0	0
FE3	011	0	1	0	0	1	0	0	0
FE4	100	0	1	0	0	0	1	1	0
FE5	101	0	1	0	0	0	1	1	0
FE6	110	0	1	0	0	1	0	1	0
FE7	111	0	1	0	0	1	0	1	0

The following configuration example selects Hall Sensor 0 and assigns it to the SIN signal bus:

Table 17 Example: Readout of a Single Hall Sensor (Sensor #0)

	Addr	testEN	SenseEN	NC	NC	COS_EN	SIN_EN	Inv	PD
FE0	000	0	1	0	0	0	1	0	0
FE1	001	0	0	0	0	0	0	0	0
FE2	010	0	0	0	0	0	0	0	0
FE3	011	0	0	0	0	0	0	0	0
FE4	100	0	0	0	0	0	0	0	0
FE5	101	0	0	0	0	0	0	0	0
FE6	110	0	0	0	0	0	0	0	0
FE7	111	0	0	0	0	0	0	0	0

This example uses two opposite Hall sensors 1 and 5 in differential mode and assigns the resulting signal to the COS signal bus:

Table 18 Example: Differential Measurement of two Opposite Hall Sensors (#1 and 5)

	Addr	testEN	SenseEN	NC	NC	COS_EN	SIN_EN	Inv	PD
FE0	000	0	0	0	0	0	0	0	0
FE1	001	0	1	0	0	1	0	0	0
FE2	010	0	0	0	0	0	0	0	0
FE3	011	0	0	0	0	0	0	0	0
FE4	100	0	0	0	0	0	0	0	0
FE5	101	0	1	0	0	1	0	1	0
FE6	110	0	0	0	0	0	0	0	0
FE7	111	0	0	0	0	0	0	0	0

### 11.4 Analog-Digital Converter Outputs, SIN/COS Signal Bus (Type ID: 0100)

Type ID: 0100	Byte 1								Byte 2								Byte 3							
Addr.000	12-bit ADC output: COS signal bus Upper 8 bits								12-bit ADC output: SIN signal bus Upper 8 bits								COS signal bus Lower 4 bits				SIN signal bus Lower 4 bits			
	11	10	9	8	7	6	5	4	11	10	9	8	7	6	5	4	3	2	1	0	3	2	1	0

The analog signals on the SIN- and COS- buses are converted into a signed 12-bit digital value by two ADC's, one for each bus.

To read the signal from one or more Hall Sensors, first assign a signal bus (SIN, COS) for each Hall Sensor in the Hall Sensor front-end and then read the corresponding amplitude value from the ADC output register.

Note that the ADC's are 14-bit (see block diagram,

Figure 2), but only 12-bit are available to the user. The available 12-bit ADC output is again split into an upper 8-bit block (available in bytes 1 & 2) and a lower 4-bit block in byte 3. The resulting 12-bit value is formatted as a signed 12-bit value and has a range from -2048...+2047 (decimal). Bit 11 (MSB) is the sign bit; if this bit is set, the Sin/Cos value is negative.

### 11.5 Automatic Gain Control Register (Type ID: 0111)

The Automatic Gain Control is active in the "green" range of the magnetic field, when the magnetic field is within ~35...63mT. If the magnetic field is too low, e.g. when the magnet is too far away from the chip, the AGC register will be FF<sub>H</sub>, if the magnetic field is too strong, e.g. when the magnet is too close to the chip, the AGC register will be 00<sub>H</sub>. The Automatic Gain control can be disabled by writing a value into this register. It will be enabled by reading from this register.

The AGC tries to maintain a constant magnitude value of 3F<sub>H</sub>. If the AGC has reached its upper or lower limit, the magnitude value can no longer be maintained at 3F<sub>H</sub> and will also change accordingly (see 11.1.3 and 11.6).

Type ID: 0111	Byte 1							
Addr. 000	AGC7	AGC6	AGC5	AGC5	AGC3	AGC2	AGC1	AGC0

### 11.6 AGC and Magnitude Registers

The AS5046 allows the readout of two additional registers related to magnetic field strength: magnitude and AGC registers. Figure 9 shows a graphic example of the interrelations of these two registers in respect to the magnetic field strength of the magnet (all register levels are in decimal format).

At a low magnetic field strength (below level B1 / B2) the magnitude will be <32 and the AGC will be at maximum: 255. The LIN status bit will be set (red range). It is not recommended to operate in this range, although the AS5046 will still produce usable results at very weak magnetic fields.

If the magnetic field strength is further increased above a magnitude value of 32, LIN will be cleared. The AGC will remain at 255 until the magnitude has reached a value of 63 (yellow range; level B3/B4). The angular data can still be used in the yellow range, but the noise (=jitter) will be larger than normal.

Once the magnitude is strong enough to reach a value of 63, the AGC will regulate the internal loop gain to maintain this value. Magnitude will remain at 63 and the AGC will regulate between 0 and 255 (green range; magnetic field strength between level B3/B4 and B5/B6). This is the recommended operating range.

If the magnetic field strength rises further than B5/B4, the AGC can no longer regulate the loop and will be at its minimum value of 0. The magnitude value will increase (yellow range; up to B7/B8). In this range, the angular data will still be valid. Due to the rather strong field, there is no issue with noise, but the magnetic field may be more distorted than in the normal operating range which may lead to additional errors.

Above level B7/B8 the LIN alarm will be set once the magnitude has exceeded a level of 95 (red range). It is not recommended to operate in this range. The main contributing part for errors will be a more distorted magnetic field.

If the magnitude exceeds a value of 127, the COF (cordic overflow) alarm will be set. This case can only occur with very strong magnets and does usually not occur in practice. The angular data will be invalid when the COF bit is set.

Figure 9 Magnitude and AGC Values vs. Magnetic Field Strength

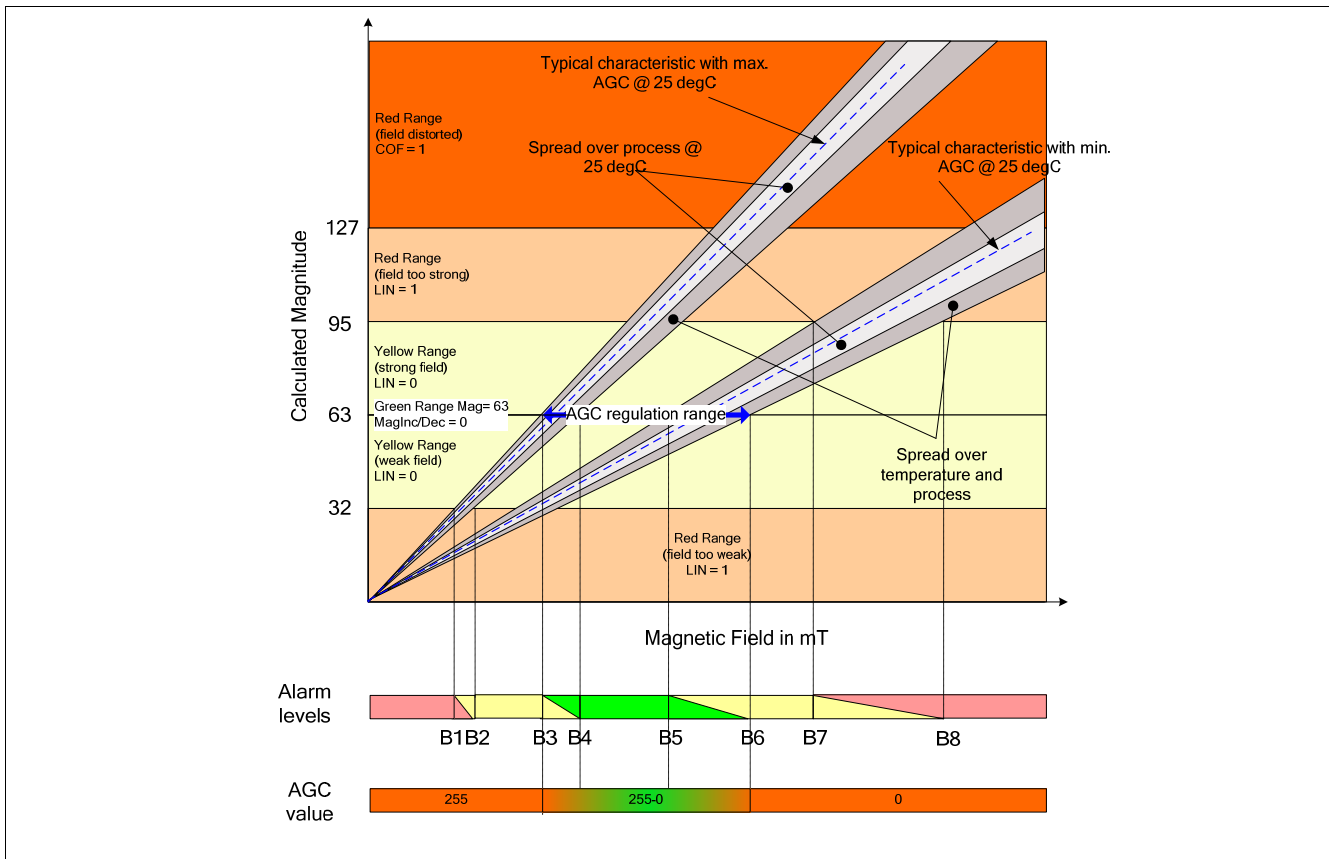

Table 19 Magnitude and AGC Values

Parameter	Symbol	Min	Typ	Max	Unit	Note
Input Field tolerance level red2yellow B1 - B2	B <sub>r2y25</sub>	16.77	17.95	19.33	mT	At 25°C ambient temperature
Input Field tolerance level yellow2green B3 - B4	B <sub>y2g25</sub>	33.01	35.35	38.06	mT	
Input Field tolerance level green2yellow B5 - B6	B <sub>g2y25</sub>	60.0	64.24	69.15	mT	
Input Field tolerance level yellow2red B7 – B8	B <sub>y2r25</sub>	90.45	96.87	104.28	mT	
Input Field tolerance level red2yellow B1 - B2	B <sub>r2y</sub>	15.64	17.95	22.37	mT	Over the full specified temperature range
Input Field tolerance level yellow2green B3 - B4	B <sub>y2g</sub>	30.80	35.35	44.05	mT	
Input Field tolerance level green2yellow B5 - B6	B <sub>g2y</sub>	55.96	64.24	80.04	mT	
Input Field tolerance level yellow2red B7 – B8	B <sub>y2r</sub>	84.39	96.87	120.69	mT	

### 11.7 Z-Axis Range Indication (Push Button Feature, Red/Yellow/Green Indicator)

The AS5046 provides several options of detecting movement and distance of the magnet in the vertical (Z-) direction. Signal indicators MagINC, MagDEC and LIN are available as status bits in the serial data stream, while MagRngn is an open-drain output that indicates an out-of range status (on in YELLOW or RED range). Additionally, the analog output provides a safety feature in the form that it will be turned off when the magnetic field is too strong or too weak (RED range).

The serial data is always available, the red/yellow/green status is indicated by the status bits as shown below:

Table 20 Magnetic Field Strength Indicators

Status Bits			Hardware Pins		Description
Mag INC	Mag DEC	LIN	Mag Rngn	Analog output	
0	0	0	Off	enabled	No distance change Magnetic Input Field OK (GREEN range, ~45...75mT)
0	1	0	Off	enabled	Distance increase, GREEN range; Pull-function. This state is dynamic and only active while the magnet is moving away from the chip.
1	0	0	Off	enabled	Distance decrease, GREEN range; Push- function. This state is dynamic and only active while the magnet is moving towards the chip.
1	1	0	On	enabled	YELLOW Range: Magnetic field is ~ 25...45mT or ~75...135mT. The AS5046 may still be operated in this range, but with slightly reduced accuracy.
1	1	1	On	disabled	RED Range: Magnetic field is ~<25mT or >~135mT. The analog output will be turned off in this range by default. It can be enabled permanently by OTP programming (see 14.1.2). It is still possible to use the absolute serial interface in the red range, but not recommended.

## 12 Mode Input Pin

The absolute angular position is sampled at a rate of 10.4kHz ( $t=96\mu\text{s}$ ) in fast mode and at a rate of 2.6kHz ( $t=384\mu\text{s}$ ) in slow mode.

These modes are selected by pin MODE (#2). The mode input pin activates or deactivates an internal filter, which is used to reduce the digital jitter and consequently the analog output noise.

The MODE pin must be connected to GND or VDD5V depending on the wanted operation mode. Changing the level of the MODE pin during operation is not allowed.

Activating the filter by pulling Mode = LOW or leaving it open reduces the transition noise to  $<0.03^\circ$  rms. At the same time, the sampling rate is reduced to 2.6kHz and the signal propagation delay is increased to 384 $\mu\text{s}$ . This mode is recommended for high precision, low speed and  $\leq 360^\circ$  applications.

Deactivating the filter by setting Mode = HIGH increases the sampling rate to 10.4kHz and reduces the signal propagation delay to 96 $\mu\text{s}$ . The transition noise will increase to  $<0.06^\circ$  rms. This mode is recommended for higher speed and full scale =  $360^\circ$  applications.

Switching the MODE pin affects the following parameters:

Table 21 Mode Pin Settings

Parameter	Slow Mode (Pin MODE = 0 or open)	Fast Mode (Pin MODE = 1)
Sampling rate	2.61 kHz (383 $\mu\text{s}$ )	10.42 kHz (95.9 $\mu\text{s}$ )
Transition noise (1 sigma)	$\leq 0.03^\circ$ rms	$\leq 0.06^\circ$ rms
Propagation delay	384 $\mu\text{s}$	96 $\mu\text{s}$
Startup time	20ms	80ms

Pin MODE should be fixed at power-up. A mode change during operation is not recommended.

## 13 Parallel Mode

The Parallel Mode allows connection of up to 8 AS5046's in parallel on the SCL and SDA line, maintaining just two wires for data transmission. This mode is accomplished by connecting all the SDA and SCL inputs/outputs in parallel. Each AS5046 device can be programmed one address ranging from 0...7 (see Table 14)

Figure 10 Parallel Connection of up to 8 Devices

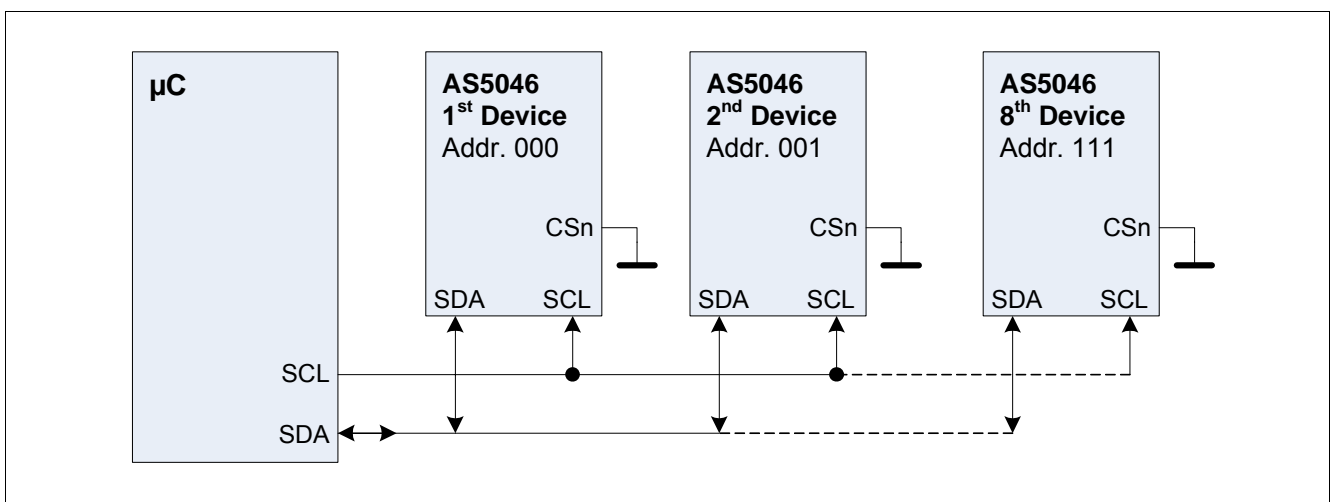

Note that the parallel connection has some restrictions:

- Each unit must be programmed to have a different address (ranging from 000 to 111; see *Table 14*)
- Changing the address also changes the analog mode, as these OTP bits share the same position. (see *Figure 13*)
- Only the SIU containing angle data and status bits can be read from parallel devices (type ID 0101). The other registers all share the same type identifier (0001, 1011, 0111; see *Table 14*), which would lead to data collision when trying to read any of these registers from parallel devices.

## 14 Ratiometric Analog Angle Output

The analog output  $V_{out}$  provides an analog voltage that is proportional to the angle of the rotating magnet and ratiometric to the supply voltage  $V_{DD5V}$  (max. 5.5V). It can source or sink currents up to  $\pm 1\text{mA}$  in normal operation (up to 66mA short circuit current).

The analog output block consists of a digital angular range selector, a 10-bit Digital-to-Analog converter and an OPAMP buffer stage (see *Figure 17*).

The digital range selector allows a preselection of the angular range for 360°, 180°, 90° or 45° (see *Table 23*). Fine-tuning of the angular range can be accomplished by adjusting the gain of the OPAMP buffer stage.

The reference voltage for the Digital-to-Analog converter (DAC) can be taken internally from  $V_{DD5V} / 2$ . In this mode, the output voltage is ratiometric to the supply voltage.

Alternatively, an external DAC reference can be applied at pin DACref (#9). In this mode, the analog output is ratiometric to the external reference voltage.

An on-chip diagnostic feature turns the analog output off in case of an error (broken supply or magnetic field out of range; see *Figure 17*). The DAC output can be accessed directly at pin #10 DACout.

The addition of an OPAMP to the DAC output allows a variety of user configurable options, such as variable output voltage ranges and variable output voltage versus angle response. By adding an external transistor, the analog voltage output can be buffered to allow output currents up to hundred milliamperes or more.

Furthermore, the OPAMP can be configured as constant current source.

As an OTP option, the DAC can be configured to 2 different output ranges:

- a) 0...100%  $V_{DACref}$ . The reference point may be either taken from  $V_{DD5V}/2$  or from the external DACref input. The 0...100% range allows easy replacement of potentiometers. Due to the nature of rail-to-rail outputs, the linearity will degrade at output voltages that are close to the supply rails.
- b) 10...90%  $V_{DACref}$ . This range allows better linearity, as the OPAMP is not driven to the rails. Furthermore, this mode allows failure detection, when the analog output voltage is outside of the normal operating range of 10...90%VDD, as in the case of broken supply or when the magnetic field is out of range and the analog output is turned off.

### 14.1 Analog Output Voltage Modes

The Analog output voltage modes are programmable by OTP. Depending on the application, the analog output can be selected as rail-to-rail output or as clamped output with 10%-90%  $V_{DD5V}$ .

The output is ratiometric to the supply voltage ( $V_{DD5V}$ ), which can range from 3.0V to 5.5V. If the DAC reference is switched to an external reference (pin DACref), the output is ratiometric to the external reference.

#### 14.1.1 Full Scale Mode

This output mode provides a ratiometric DAC output of  $(0\% \text{ to } 100\%) \times V_{ref}^*)$ , amplified by the OPAMP stage (default = internal 2x gain, see *Figure 17*)

Figure 11 Analog Output, Full Scale Mode (shown for 360° mode)

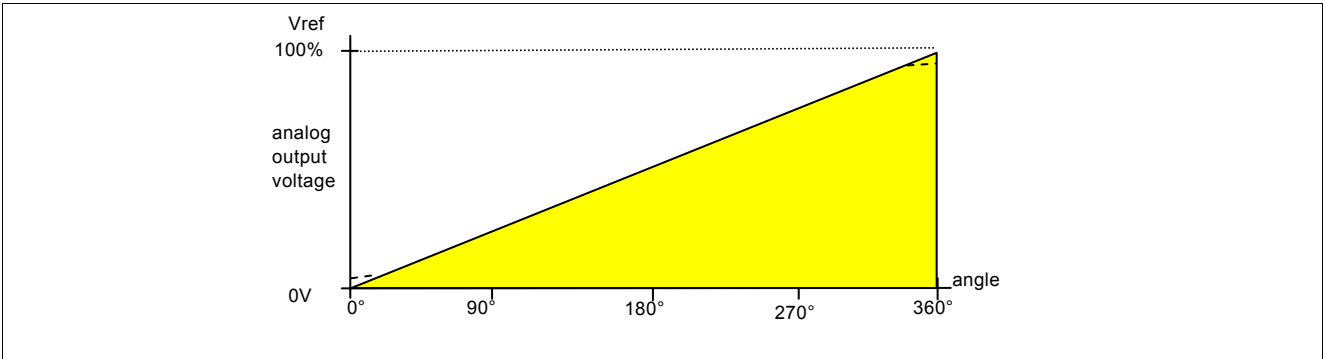

Note:

- 1) For simplification, Figure 11 describes a linear output voltage from rail to rail (0V to VDD). In practice, this is not feasible due to saturation effects of the OPAMP output driver transistors. The actual curve will be rounded towards the supply rails (as indicated in Figure 11).
- 2) Figure 11 and are shown for 360° operation. See Table 23 (page 29) for further angular range programming options.

### 14.1.2 Diagnostic Output Mode

Figure 12 Diagnostic Output Mode

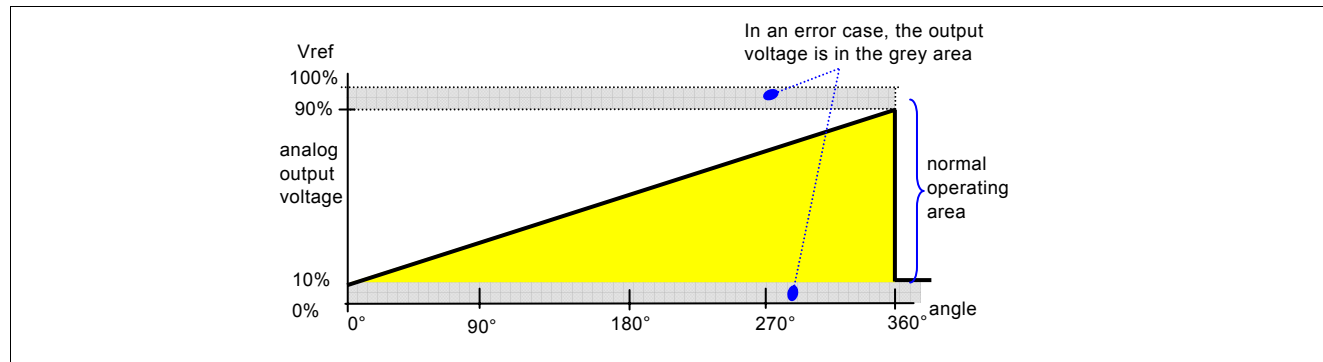

In Diagnostic Output Mode (see Figure 12) the analog output of the internal DAC ranges from 10% - 90% Vref<sup>1)</sup>. In an error case, either when the supply is interrupted or when the magnetic field is in the “red” range, (see Table 20) the output is switched to 0V and thus indicates the error condition.

It is possible to enable the analog output permanently (it will not be switched off even if the magnetic field is out of range). To enable this feature an OTP bit in the factory setting must be set. The corresponding bit is FS6. See Application Note AS5040-20 (Extended features of OTP programming) for further details. The application note is available for download at the austriamicrosystems website.

The analog and digital outputs will have the following conditions:

Table 22 Conditions for Analog and Digital Outputs

Status	DAC Output Voltage	Serial Digital Output
Normal operation	10% - 90% Vref <sup>1)</sup>	#0 - #1023 (0°-360°), MagRngn = 1
Magnetic field out of range	< 10% Vref <sup>1)</sup> , DAC output is switched to 0V (this feature may be disabled in OTP; see text)	#0 - #1023 (0°-360°) out of range is signaled in status bits: MagInc=MagDec=LIN=1, MagRngn= 0



Status	DAC Output Voltage	Serial Digital Output
Broken positive power supply (V <sub>OUT</sub> pull down resistor at receiving side)	< 10% VDD <sup>2)</sup>	The serial data bits read by the serial interface will be either all “0”-s or all “1”-s, indicating a non-valid output
Broken power supply ground (V <sub>OUT</sub> pull down resistor at receiving side)	< 10% VDD <sup>2)</sup>	
Broken positive power supply (V <sub>OUT</sub> pull up resistor at receiving side)	> 90% VDD <sup>2)</sup>	
Broken power supply ground (V <sub>OUT</sub> pull up resistor at receiving side)	> 90% VDD <sup>2)</sup>	

Notes:

- 1) V<sub>ref</sub> = internal: ½ \* VDD5V (pin #16) or external: V<sub>DACref</sub> (pin#9), depending on Ref\_extEN bit in OTP (0=int., 1=ext.)
- 2) VDD = positive supply voltage at receiving side (3.0 – 5.5V)

## 15 Programming the AS5046

After power-on, programming the AS5046 is enabled with the rising edge of CS<sub>n</sub> and Prog = logic high. 16 bit configuration data must be serially shifted into the OTP register via the Prog-pin. The first “CCW” bit is followed by the zero position data (MSB first) and the Analog Output Mode setting as shown in *Table 23*. Data must be valid at the rising edge of CLK (see *Figure 13*). Following this sequence, the voltage at pin Prog must be raised to the programming voltage V<sub>PROG</sub> (see *Figure 14*). 16 CLK pulses (t<sub>PROG</sub>) must be applied to program the fuses. To exit the programming mode, the chip must be reset by a power-on-reset. The programmed data is available after the next power-up.

Note: During the programming process, the transitions in the programming current may cause high voltage spikes generated by the inductance of the connection cable. To avoid these spikes and possible damage to the IC, the connection wires, especially the signals PROG and VSS must be kept as short as possible. The maximum wire length between the V<sub>PROG</sub> switching transistor and pin PROG (*Figure 15*) should not exceed 50mm (2 inches).

To suppress eventual voltage spikes, a 10nF ceramic capacitor should be connected close to pins PROG and VSS. This capacitor is only required for programming, it is not required for normal operation. The clock timing t<sub>clk</sub> must be selected at a proper rate to ensure that the signal PROG is stable at the rising edge of CLK (see *Figure 13*). Additionally, the programming supply voltage should be buffered with a 10µF capacitor mounted close to the switching transistor. This capacitor aids in providing peak currents during programming. The specified programming voltage at pin PROG is 7.3 – 7.5V (see section *Programming Conditions*). To compensate for the voltage drop across the V<sub>PROG</sub> switching transistor, the applied programming voltage may be set slightly higher (7.5 - 8.0V, see *Figure 15*).

### OTP Register Contents:

#### CCW Counter Clockwise Bit

- ccw=0 – angular value increases with clockwise rotation
- ccw=1 – angular value increases with counterclockwise rotation

**Z [9:0]:** Programmable Zero / Index Position

**FB\_intEN:** OPAMP gain setting: 0=external, 1=internal; this bit also sets device address bit A2 !

**RefExtEN:** DAC reference: 0=internal, 1=external; this bit also sets device address bit A1 !

**ClampMd EN:** Analog output span: 0=0-100%, 1=10-90%\*VDD; this bit also sets device address bit A0

#### Output Range (OR0, OR1):

Analog Output Range Selection			
[1:0]	00 = 360°	01 = 180°	
	10 = 90°	11 = 45°	

#### Disable shutdown of analog output:

see 14.1.2

Figure 13 Programming Access – OTP Write Cycle (section of Figure 14)

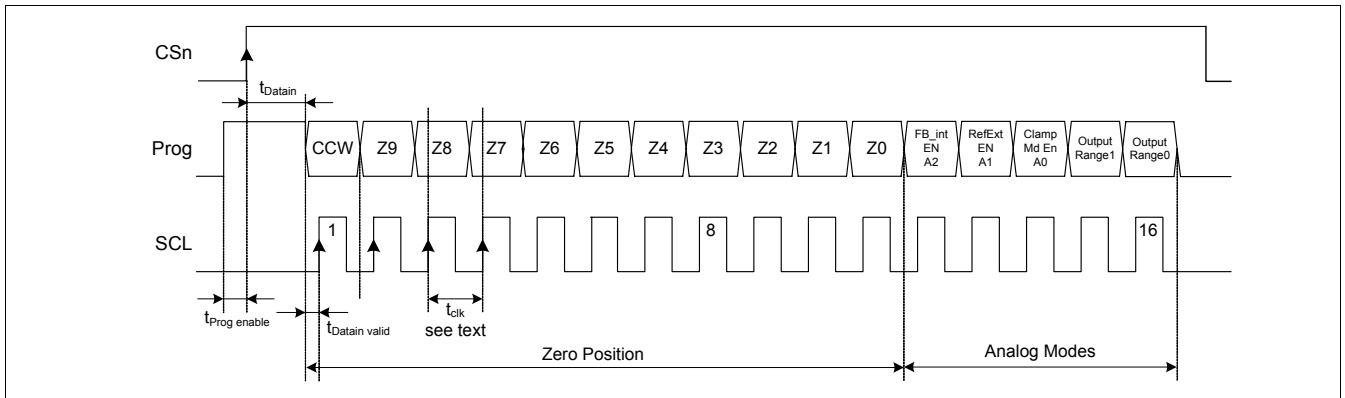

Figure 14 Complete OTP Programming Sequence

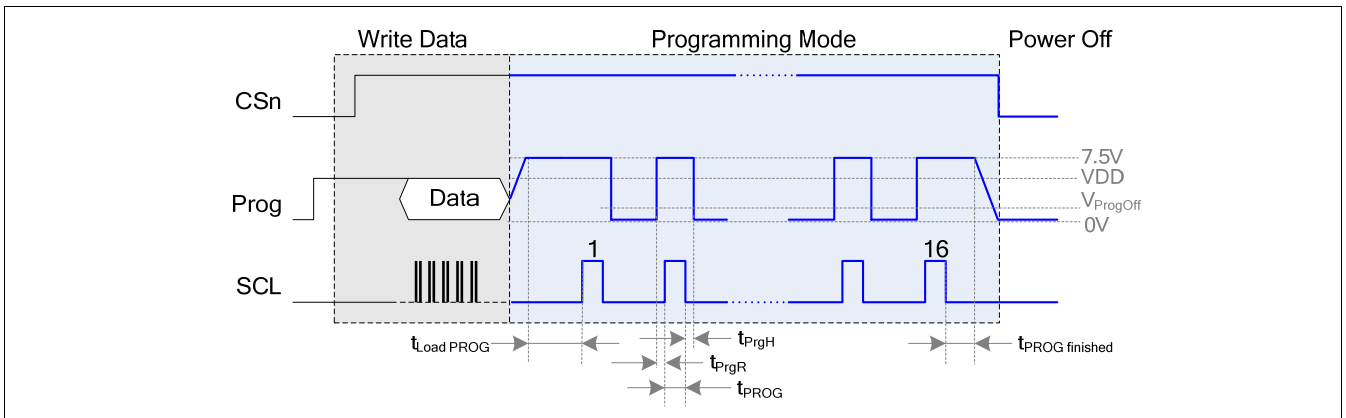
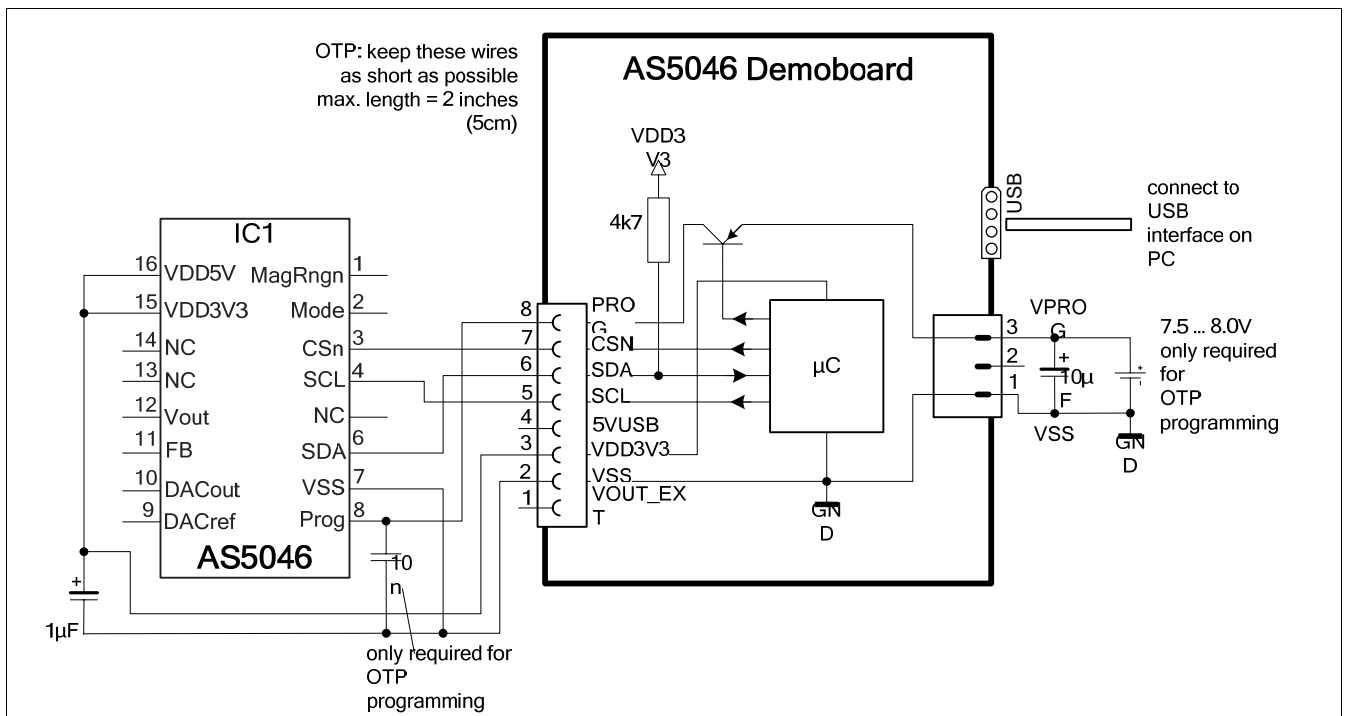

Figure 15 OTP Programming Hardware Connection of AS5046 (shown with AS5046 demoboard)



## 15.1 Zero Position Programming

The AS5046 allows easy assembly of the system, as the actual angle of the magnet does not need to be considered. By OTP programming, any position can be assigned as the new permanent zero position with an accuracy of 0.35° (all modes).

Using the same procedure, the AS5046 can be calibrated to assign a given output voltage to a given angle. With this approach, all offset errors (DAC + OPAMP) are also compensated for the calibrated position.

Essentially, for a given mechanical position, the angular measurement system is electrically rotated (by changing the Zero Position value in the OTP register), until the output matches the desired mechanical position.

The example in *Figure 16* below shows a configuration for 5V supply voltage and 10%-90% output voltage range. It adjusted by Zero Position Programming to provide an analog output voltage of 2.0 Volts at an angle of 180°. The slope of the curve may be further adjusted by changing the gain of the OPAMP output stage and by selecting the desired angular range (360°/180°/90°/45°).

Figure 16 Zero Position Programming (shown for 360° mode)

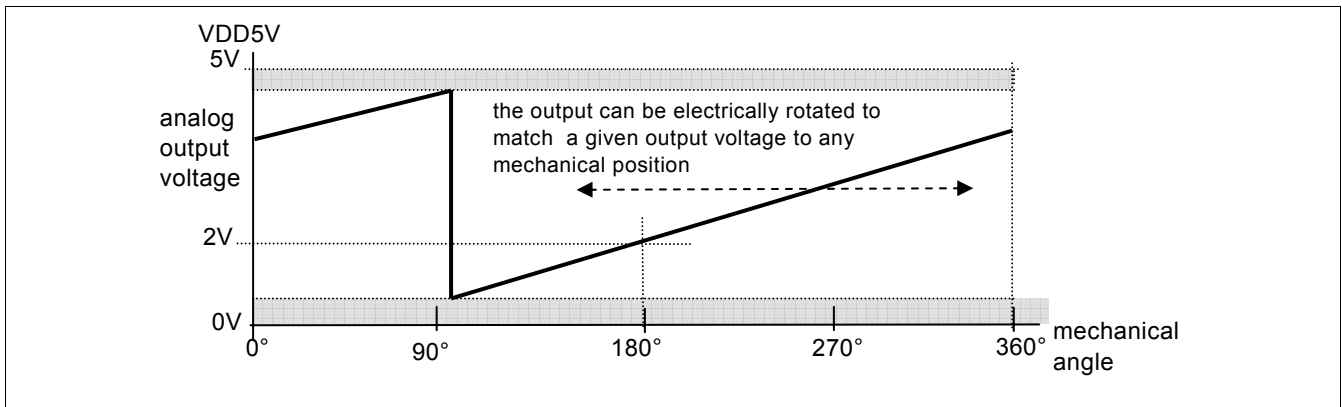

## 15.2 Analog Mode Programming

The analog output can be configured in many ways:

It consists of three major building blocks,  
 a digital range preselector,  
 a 10-bit Digital-to-Analog-Converter (DAC) and  
 an OP-AMP buffer stage.

In the default configuration (all OTP bits = 0), the analog output is set for 360° operation, internal DAC reference (VDD5V/2), external OPAMP gain, 0-100% ratiometric to VDD5V.

Shown below is a typical example for a 0°-360° range, 0-5V output. The complete application requires only one external component, a buffer capacitor at VDD3V3 and has only 3 connections VDD, VSS and Vout (connectors 1-3).

*Note: the default setting for the OPAMP feedback path is: FB\_intEn=0=external. The external resistors Rf and Rg must be installed. In the programmed state (FB\_intEn=1=internal), these resistors do not need to be installed as the feedback path is internal (Rf\_int and Rg\_int).*

Figure 17 Analog Output Block Diagram

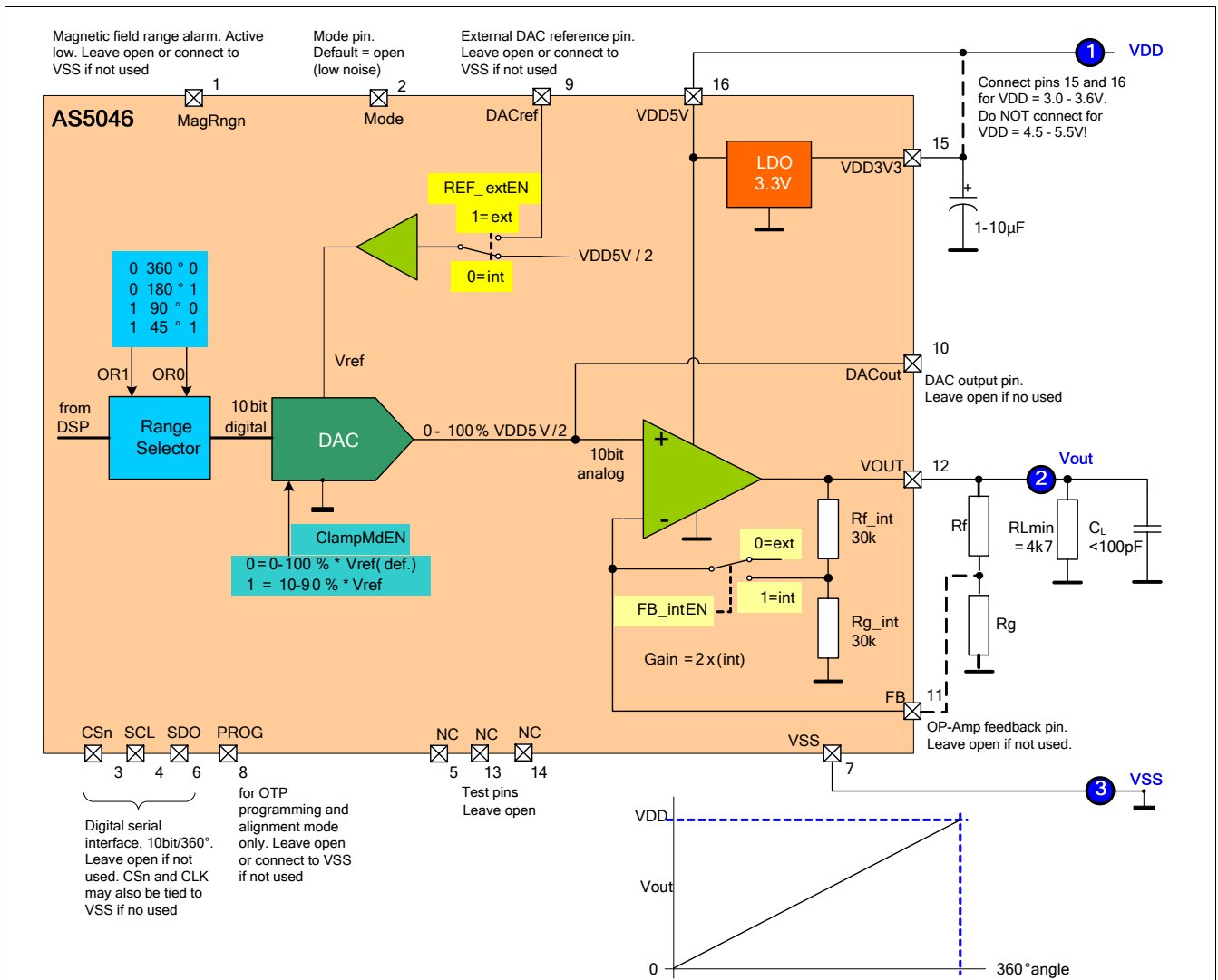

### 15.2.1 Angular Range Selector

The Angular Range selector allows a digital pre-selection of the angular range. The AS5046 can be configured for a full scale angular range of 45°, 90°, 180° or 360°. In addition, the Output voltage versus angle response can be fine-tuned by setting the gain of the OP-AMP with external resistors and the maximum output voltage can be set in the DAC.

The combination of these options allows to configure the operation range of the AS5046 for all angles up to 360° and output voltages up to 5.5V.

The response curve for the analog output is linear for the selected range (45°/90°/180°/360°). In addition, the slope is mirrored at 180° for 45°- and 90°- modes and has a step response at 270° for the 180°-mode. This allows the AS5046 to be used in a variety of applications. In these three modes, the output remains at  $V_{out,max}$  and  $V_{out,min}$  to avoid a sudden output change when the mechanical angle is rotated beyond the selected analog range. In 360°-mode, a jitter between  $V_{out,max}$  and  $V_{out,min}$  at the 360° point is also prevented due to a hysteresis.

Table 23 Digital Range Selector Programming Option

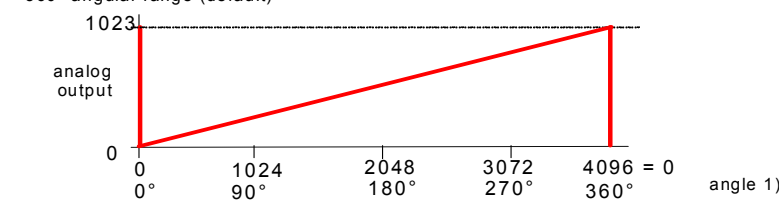
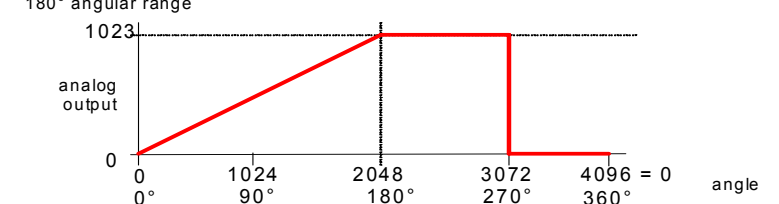
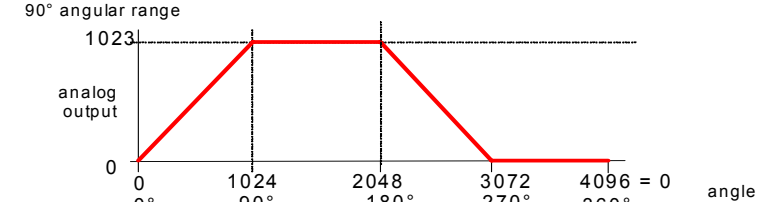
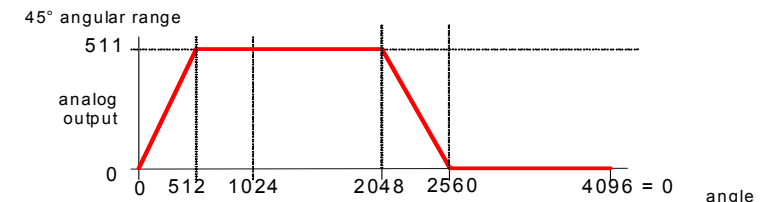
Output Range1	Output Range0	Mode	Note
0	0	360° angular range (default) 	Default mode, analog resolution= 10bit (1024 steps) over 360° analog step size: 1LSB = 0.35° (10bit)
0	1	180° angular range 	Analog resolution= 10bit (1024 steps) over 180° Analog step size: 1LSB = 0.175° (11bit)
1	0	90° angular range 	Analog resolution= 10bit (1024 steps) over 90° Analog step size: 1LSB = 0.088° (12bit)
1	1	45° angular range 	Analog resolution= 9 bit (512 steps) over 45° Analog step size: 1LSB = 0.088° (12bit)

Note:

1) The resolution on the digital serial interface is always 12bit (0.088°/step) over 360°, independent of analog mode

### 15.3 Repeated OTP Programming

Although a single AS5046 OTP register bit can be programmed only once (from 0 to 1), it is possible to program other, unprogrammed bits in subsequent programming cycles. However, a bit that has already been programmed should not be programmed twice. Therefore it is recommended that bits that are already programmed are set to “0” during a programming cycle.

### 15.4 Non-permanent Programming

It is also possible to re-configure the AS5046 in a non-permanent way by overwriting the OTP register. This procedure is essentially a “Write Data” sequence (see Figure 13) without a subsequent OTP programming cycle. The “Write Data” sequence may be applied at any time during normal operation. This configuration remains set while the power supply voltage is above the power-on reset level (see 7.5). See Application Note AN5000-20 for further information.

## 15.5 Digital-to-Analog Converter (DAC)

The DAC has a resolution of 10bit (1024 steps) and can be configured for the following options

### Internal or external reference

The default DAC reference is the voltage at pin #16 (VDD5V) divided by 2 (see *Figure 17*). Using this reference, a system that has an output voltage ratiometric to the supply voltage can be built.

Optionally, an external reference source, applied at pin#9 (DACref) can be used. This programming option is useful for applications requiring a precise output voltage that is independent of supply fluctuations, for current sink outputs or for applications with a dynamic reference, e.g. attenuation of audio signals.

### 0-100% or 10-90% full scale range

The reference voltage for the DAC is buffered internally. The recommended range for the external reference voltage is 0.2V to (VDD3V3 -0.2)V.

The DAC output voltage will be switched to 0V, when the magnetic field is out of range, when the MagInc and MagDec indicators are both =1 and the MagRngn-pin (#1) will go low.

The default full scale output voltage range is 0-100%\*VDD5V. Due to limitations in the output stage of an OP-Amp buffer, it cannot drive the output voltage from 0-100% rail-to-rail. Without load, the minimum output voltage at 0° will be a few millivolts higher than 0V and the maximum output voltage will be slightly lower than VDD5V. With increasing load, the voltage drops will increase accordingly.

As a programming option, an output range of 10-90%\*VDD5V can be selected. In this mode, there is no saturation at the upper and lower output voltage limits like in the 0-100% mode and it allows failure detection as the output voltage will be outside the 10-90% limits, when the magnetic field is in the "red" range ( $V_{out}=0V$ , see *Table 20*) or when the supply to the chip is interrupted ( $V_{out}=0V$  or VDD5V).

The unbuffered output of the DAC is accessible at pin #10 (DACout). This output must not be loaded.

## 15.6 OP-AMP Stage

The DAC output is buffered by a non-inverting Op-Amp stage. The amplifier is supplied by VDD5V (pin #16) and can hence provide output voltages up to 5V.

By allowing access to the inverting input of the Op-Amp and with the addition of a few discrete components it can be configured in many ways, like high current buffer, current sink output, adjustable angle range, etc...

Per default, the gain of the Op-Amp must be set by two external resistors (see *Figure 17*). Optionally, the fixed internal gain setting (2x) may be programmed by OTP, eliminating the need for external resistors.

### 15.6.1 Output Noise

The Noise level at the analog output depends on two states of the digital angular output:

- a) the digital angular output value is stable

In this case, the output noise is the figure given as  $V_{noise}$  in section 7.3.6. Note that the noise level is given for the default gain of 2x for other gains, it must be scaled accordingly.

- b) the digital output is at the edge of a step

In this case, the digital output may jitter between two adjacent values. The rate of jitter is specified as transition noise (parameter TN in paragraph 7.5). The resulting output noise is calculated by:

$$V_{noise,Vout} = \frac{TN * VDD5V}{360} + V_{noise,OPAMP}$$

where:

$V_{noise, Vout}$	= noise level at pin Vout in Vrms
TN	= transition noise (in °rms; see 7.5)
VDD5V	= supply voltage VDD5V in V
$V_{noise,OPAMP}$	= noise level of OPAMP (paragraph 0) in Vrms

## 15.7 Application Examples

Application Note AN5043-10 shows various application examples for the AS5043 encoder IC. The same application examples apply for the analog output of the AS5046.

## 16 Analog Readback Mode

Non-volatile programming (OTP) uses on-chip zener diodes, which become permanently low resistive when subjected to a specified reverse current.

The quality of the programming process depends on the amount of current that is applied during the programming process (up to 130mA). This current must be provided by an external voltage source. If this voltage source cannot provide adequate power, the zener diodes may not be programmed properly.

In order to verify the quality of the programmed bits, an analog level can be read for each zener diode, giving an indication whether this particular bit was properly programmed or not.

To put the AS5046 in Analog Readback Mode, a digital sequence must be applied to pins CSn, PROG and CLK as shown in *Figure 18*. The digital level for this pin depends on the supply configuration (3.3V or 5V; see section 9).

The second rising edge on CSn (OutpEN) changes pin PROG to a digital output and the log. high signal at pin PROG must be removed to avoid collision of outputs (grey area in *Figure 18*).

The following falling slope of CSn changes pin PROG to an analog output, providing a reference voltage  $V_{ref}$ , that must be saved as a reference for the calculation of the subsequent programmed and unprogrammed OTP bits.

Following this step, each rising slope of CLK outputs one bit of data in the reverse order as during programming. (see *Figure 18*: Output Range OR0 and -1, ClampMdEN, RefExtEn, FB\_IntEn, Z0...Z9, ccw)

During analog readback, the capacitor at pin PROG (see *Figure 15*) should be removed to allow a fast readout rate.

The measured analog voltage for each bit must be subtracted from the previously measured  $V_{ref}$ , and the resulting value gives an indication on the quality of the programmed bit: a reading of <100mV indicates a properly programmed bit and a reading of >1V indicates a properly unprogrammed bit.

A reading between 100mV and 1V indicates a faulty bit, which may result in an undefined digital value, when the OTP is read at power-up.

Following the 16<sup>th</sup> clock (after reading bit "ccw"), the chip must be reset by disconnecting the power supply.

Figure 18 Analog OTP Register Read

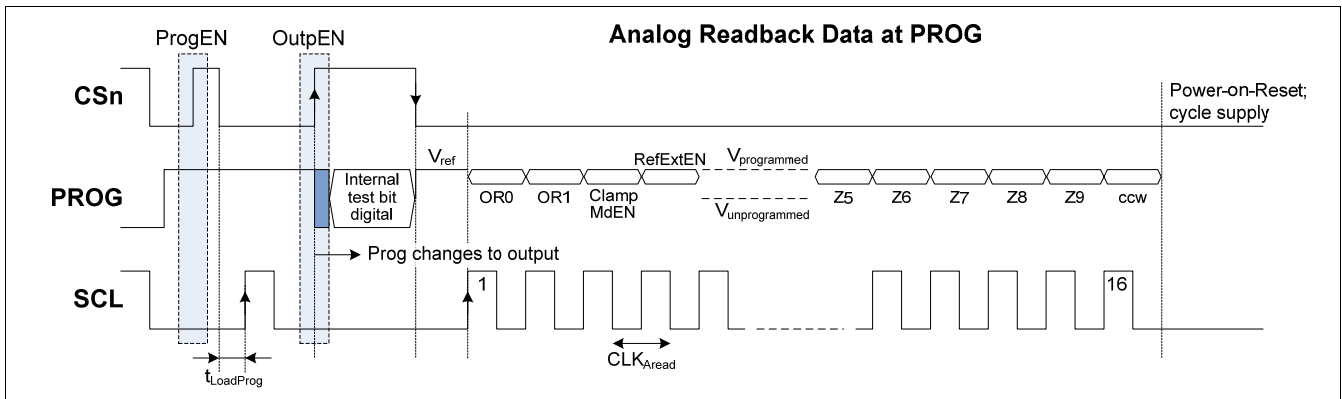

## 17 Alignment Mode

The alignment mode simplifies centering the magnet over the chip to gain maximum accuracy and XY-alignment tolerance.

This electrical centering method allows a wider XY-alignment tolerance (0.485mm radius) than mechanical centering (0.25mm radius) as it eliminates the placement tolerance of the die within the IC package (+/- 0.235mm).

Alignment mode can be enabled with the falling edge of CSn while PROG = logic high (Figure 19). The Data bits D11-D0 of the serial interface change to a 12-bit displacement amplitude output. A high value indicates large X or Y displacement, but also higher absolute magnetic field strength. The magnet is properly aligned, when the difference between highest and lowest value over one full turn is at a minimum.

Under normal conditions, a properly aligned magnet will result in a reading of less than 128 over a full turn.

Stronger magnets or short gaps between magnet and IC may show values larger than 128. These magnets are still properly aligned as long as the difference between highest and lowest value over one full turn is at a minimum.

The MagInc and MagDec indicators will be = 1 when the alignment mode reading is < 128. At the same time, hardware pin MagRngn (#1) will be pulled to VSS.

The Alignment mode can be reset to normal operation mode by a power-on-reset (cycle power supply) or by a falling edge of CSn with PROG=low (see Figure 20).

Figure 19 Enabling the Alignment Mode

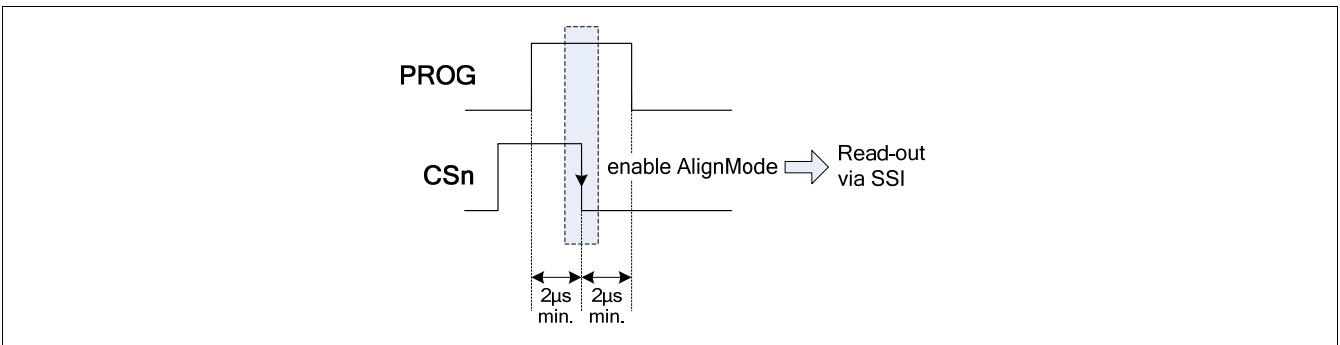
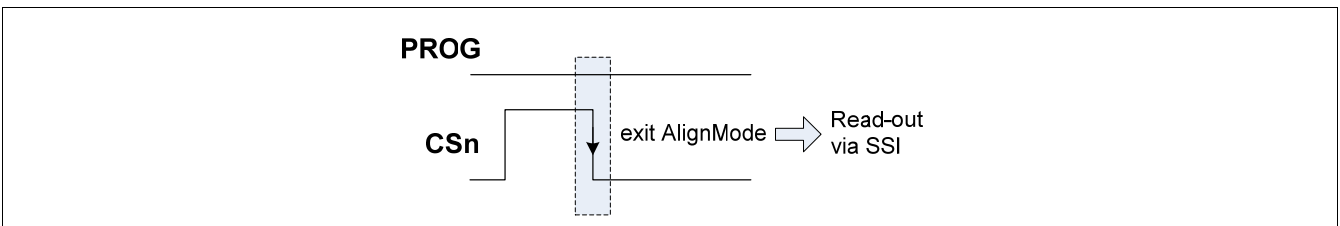

Figure 20 Exiting Alignment Mode





## 18 Choosing the Proper Magnet

Typically the magnet should be 6mm in diameter and  $\geq 2.5\text{mm}$  in height. Magnetic materials such as rare earth AlNiCo, SmCo5 or NdFeB are recommended.

The magnet's field strength perpendicular to the die surface should be verified using a gauss-meter. The magnetic field  $B_v$  at a given distance, along a concentric circle with a radius of 1.1mm (R1), should be in the range of  $\pm 45\text{mT} \dots \pm 75\text{mT}$ . (see Figure 21).

Figure 21 Typical Magnet and Magnetic Field Distribution

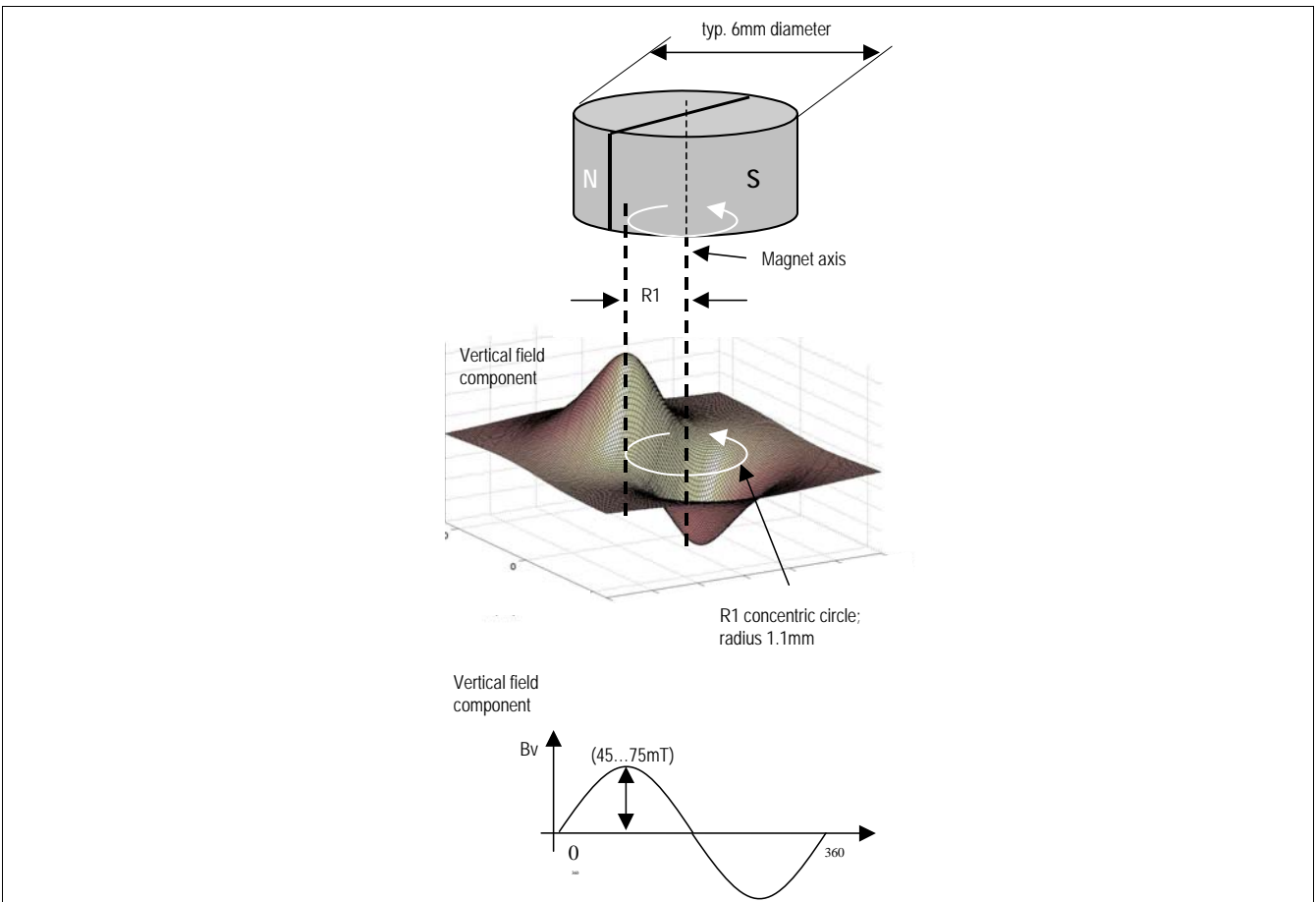

## 18.1 Physical Placement of the Magnet

The best linearity can be achieved by placing the center of the magnet exactly over the defined center of the IC package as shown *Figure 22*:

*Figure 22* Defined IC Center and Magnet Displacement Radius

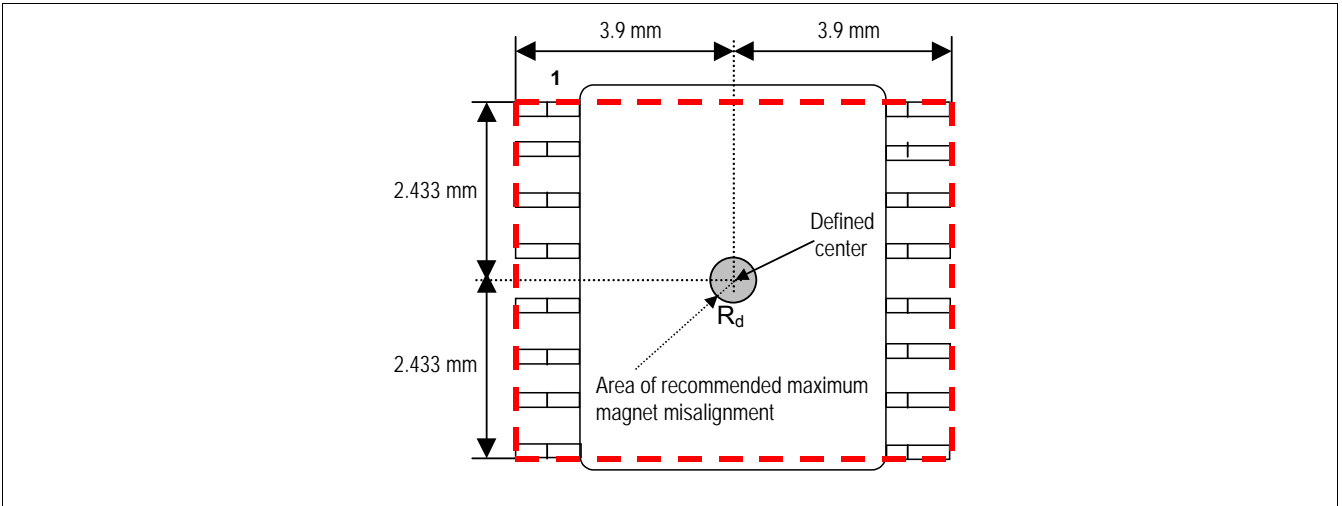

### 18.1.1 Magnet Placement

The magnet's center axis should be aligned within a displacement radius  $R_d$  of 0.25mm from the defined center of the IC with reference to the edge of pin #1 (see *Figure 22*). This radius includes the placement tolerance of the chip within the SSOP-16 package (+/- 0.235mm).

The displacement radius  $R_d$  is 0.485mm with reference to the center of the chip (see section 17 *Alignment Mode*).

The vertical distance should be chosen such that the magnetic field on the die surface is within the specified limits (see *Figure 21*). The typical distance "z" between the magnet and the package surface is 0.5mm to 1.8mm with the recommended magnet (6mm x 3mm). Larger gaps are possible, as long as the required magnetic field strength stays within the defined limits.

A magnetic field outside the specified range may still produce usable results, but the out-of-range condition will be indicated by MagRngn (pin 1), which will be pulled low. At this condition, the angular data is still available over the digital serial interface, but the analog output will be turned off.

*Figure 23* Vertical Placement of the Magnet

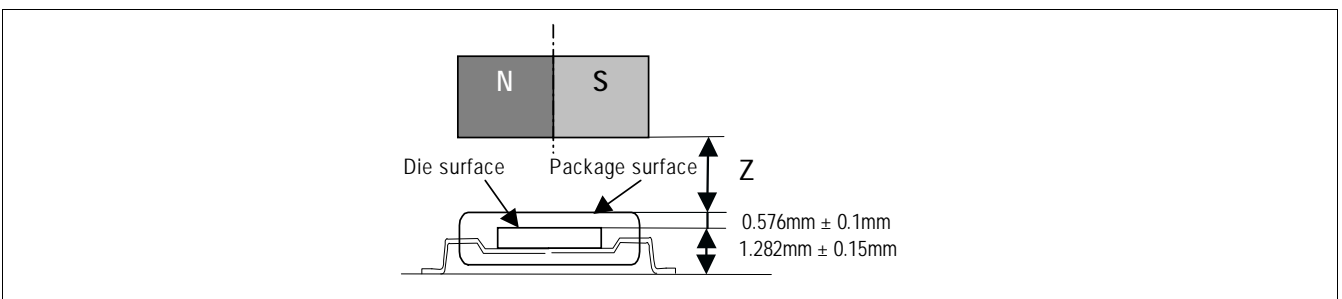

## 19 Simulation Modelling

Figure 24 Arrangement of Hall Sensor Array on Chip (principle)

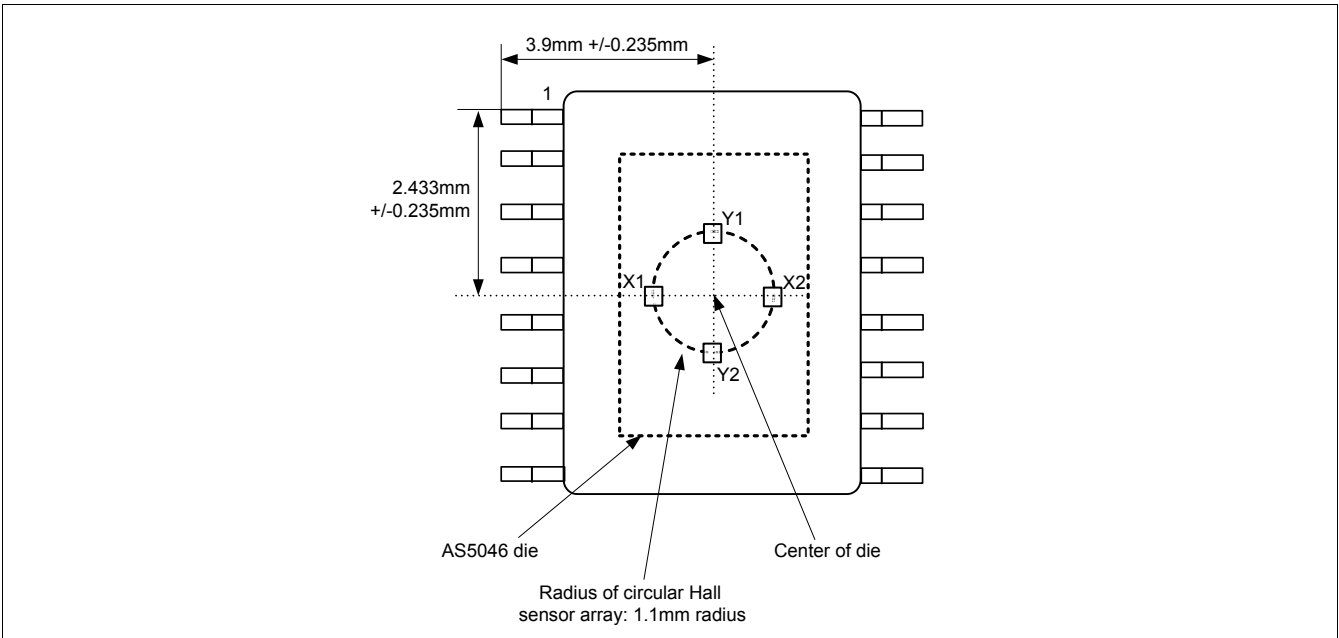

With reference to *Figure 24*, a diametrically magnetized permanent magnet is placed above or below the surface of the AS5046. The chip uses an array of Hall sensors to sample the vertical vector of a magnetic field distributed across the device package surface. The area of magnetic sensitivity is a circular locus of 1.1mm radius with respect to the center of the die. The Hall sensors in the area of magnetic sensitivity are grouped and configured such that orthogonally related components of the magnetic fields are sampled differentially.

The differential signal Y1-Y2 will give a sine vector of the magnetic field. The differential signal X1-X2 will give an orthogonally related cosine vector of the magnetic field.

The angular displacement ( $\Theta$ ) of the magnetic source with reference to the Hall sensor array may then be modelled by:

$$\Theta = \arctan \frac{(Y1 - Y2)}{(X1 - X2)} \pm 0.5^\circ$$

The  $\pm 0.5^\circ$  angular error assumes a magnet optimally aligned over the center of the die and is a result of gain mismatch errors of the AS5046. Placement tolerances of the die within the package are  $\pm 0.235\text{mm}$  in X and Y direction, using a reference point of the edge of pin #1 (*Figure 24*).

In order to neglect the influence of external disturbing magnetic fields, a robust differential sampling and ratiometric calculation algorithm has been implemented. The differential sampling of the sine and cosine vectors removes any common mode error due to DC components introduced by the magnetic source itself or external disturbing magnetic fields. A ratiometric division of the sine and cosine vectors removes the need for an accurate absolute magnitude of the magnetic field and thus accurate Z-axis alignment of the magnetic source.

The recommended differential input range of the magnetic field strength ( $B_{(X1-X2)}, B_{(Y1-Y2)}$ ) is  $\pm 75\text{mT}$  at the surface of the die. In addition to this range, an additional offset of  $\pm 5\text{mT}$ , caused by unwanted external stray fields is allowed.

The chip will continue to operate, but with degraded output linearity, if the signal field strength is outside the recommended range. Too strong magnetic fields will introduce errors due to saturation effects in the internal preamplifiers. Too weak magnetic fields will introduce errors due to noise becoming more dominant.

## 20 Failure Diagnostics

The AS5046 also offers several diagnostic and failure detection features:

### 20.1 Magnetic Field Strength Diagnosis

**By software:** the MagInc and MagDec status bits will both be high when the magnetic field is out of range.

**By hardware:** Pin #1 (MagRngn) is a logical NAND-ed combination of the MagInc and MagDec status bits. It is an open-drain output and will be turned on (= low with external pull-up resistor) when the magnetic field is out of range.

**By hardware:** Pin #12 (Vout) is the analog output of the DAC and OP-Amp. The analog output will be 0V, when the magnetic field is out of range (all analog modes).

### 20.2 Power Supply Failure Detection

**By software:** If the power supply to the AS5046 is interrupted, the digital data read by the serial interface will be all "0"s. Data is only valid, when bit OCF is high, hence a data stream with all "0"s is invalid. To ensure adequate low levels in the failure case, a pull-down resistor (~10kΩ) should be added between pin DO and VSS at the receiving side.

**By hardware:** The MagRngn pin is an open drain output and requires an external pull-up resistor. In normal operation, this pin is high ohmic and the output is high. In a failure case, either when the magnetic field is out of range or the power supply is missing, this output will become low. To ensure an adequate low level in case of a broken power supply to the AS5046, the pull-up resistor (~10kΩ) must be connected to the positive supply at pin 16 (VDD5V).

## 21 Angular Output Tolerances

### 21.1 Accuracy; Digital Outputs

Accuracy is defined as the error between measured angle and actual angle. It is influenced by several factors:

- the non-linearity of the analog-digital converters,
- internal gain and mismatch errors,
- non-linearity due to misalignment of the magnet

As a sum of all these errors, the accuracy with centered magnet =  $(Err_{max} - Err_{min})/2$  is specified as better than  $\pm 0.5$  degrees @ 25°C (see *Figure 26*).

Misalignment of the magnet further reduces the accuracy. *Figure 25* shows an example of a 3D-graph displaying non-linearity over XY-misalignment. The center of the square XY-area corresponds to a centered magnet (see dot in the center of the graph). The X- and Y- axis extends to a misalignment of  $\pm 1$ mm in both directions. The total misalignment area of the graph covers a square of 2x2 mm (79x79mil) with a step size of 100µm.

For each misalignment step, the measurement as shown in *Figure 26* is repeated and the accuracy  $(Err_{max} - Err_{min})/2$  (e.g. 0.25° in *Figure 26*) is entered as the Z-axis in the 3D-graph.

## 21.2 Accuracy; Analog Output

The analog output has the same accuracy as the digital output with the addition of the nonlinearities of the DAC and the OPAMP (+/-1LSB; see *Table 23* and *Table 8*).

Figure 25 Example of Linearity Error over XY Misalignment

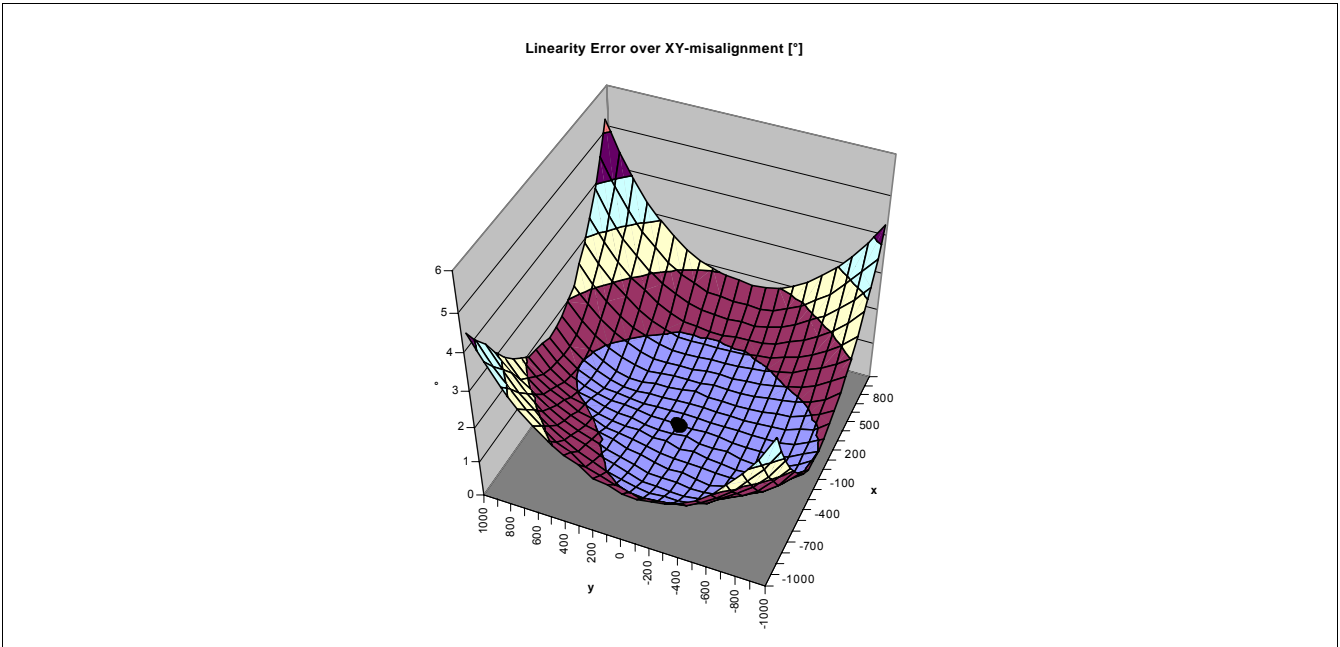

The maximum non-linearity error on this example is better than  $\pm 1$  degree (inner circle) over a misalignment radius of  $\sim 0.7$ mm. For volume production, the placement tolerance of the IC within the package ( $\pm 0.235$ mm) must also be taken into account.

The total nonlinearity error over process tolerances, temperature and a misalignment circle radius of 0.25mm is specified better than  $\pm 1.4$  degrees.

The magnet used for this measurement was a cylindrical NdFeB (Bomatec® BMN-35H) magnet with 6mm diameter and 2.5mm in height.

Figure 26 Example of Linearity Error over 360°

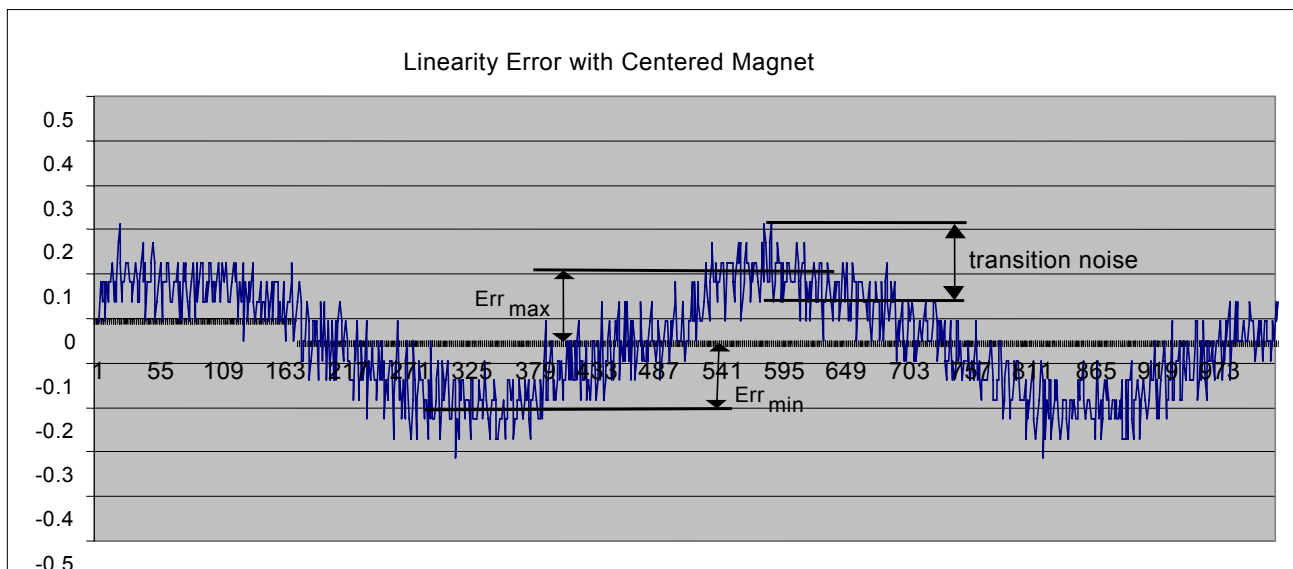

## 21.3 Transition Noise

Transition noise is defined as the jitter in the transition between two steps.

Due to the nature of the measurement principle (Hall sensors + Preamplifier + ADC), there is always a certain degree of noise involved.

This transition noise voltage results in an angular transition noise at the outputs. It is specified as 0.06 degrees rms (1 sigma)<sup>1</sup> in fast mode (pin MODE = high) and 0.03 degrees rms (1 sigma)<sup>1</sup> in slow mode (pin MODE = low or open).

These values are the repeatability of an indicated angle at a given mechanical position.

The transition noise has different implications on the type of output that is used:

- absolute output; serial interface:  
The transition noise of the absolute output can be reduced by the user by applying an averaging of readings. An averaging of 4 readings will reduce the transition noise by 6dB or 50%, e.g. from 0.03°rms to 0.015°rms (1 sigma) in slow mode
- analog output:  
Ideally, the analog output should have a jitter that is less than one digit. In 360° mode, both fast or slow mode may be selected for adequate low jitter.  
In 180°, 90° or 45° mode, where the step sizes are smaller, slow mode should be selected to reduce the output jitter.

<sup>1</sup>: statistically, 1 sigma represents 68.27% of readings,  
3 sigma represents 99.73% of readings.

## 21.4 High Speed Operation

### 21.4.1 Sampling Rate

The AS5046 samples the angular value at a rate of 10.42k samples per second (ksps) in fast mode and 2.61ksps in slow mode.

Consequently, a new reading is performed each 96µs. (fast mode) or 384µs (slow mode).

At a stationary position of the magnet, this sampling rate creates no additional error.

#### Absolute Mode:

With the given sampling rates, the number of samples (n) per turn for a magnet rotating at high speed can be calculated by

$$n = \frac{60}{rpm \cdot 96\mu s} \text{ for fast mode}$$

$$n = \frac{60}{rpm \cdot 384\mu s} \text{ for slow mode}$$

In practice, there is no upper speed limit. The only restriction is that there will be fewer samples per revolution as the speed increases.

Regardless of the rotational speed, the absolute angular value is always sampled at the highest resolution.

Table 24 Speed Performance

Fast Mode (pin Mode = 1)	Slow Mode (pin Mode = 0 or open)
610rpm = 1024 samples / turn	610rpm = 256 samples / turn
1220rpm = 512 samples / turn	1220rpm = 128 samples / turn
2441rpm = 256 samples / turn	2441rpm = 64 samples / turn
etc...	etc...

## 21.5 Output Delays

The propagation delay is the delay between the time that the sample is taken until it is available as angular data. This delay is 96µs in fast mode (pin Mode = high) and 384µs in slow mode (pin Mode = low or open).

The analog output produces no further delay, the output voltage will be updated as soon as it is available. Using the serial interface for data transmission, an additional delay must be considered, caused by the asynchronous sampling ( $0 \dots 1/f_{\text{sample}}$ ) and the time it takes the external control unit to read and process the angular data from the AS5046.

### 21.5.1 Angular Error Caused by Propagation Delay

A rotating magnet will cause an angular error caused by the propagation delay. This error increases linearly with speed:

$$e_{\text{sampling}} (\text{deg}) = 6 * \text{rpm} * \text{prop.delay}$$

where  $e_{\text{sampling}}$  = angular error [°]  
 $\text{rpm}$  = rotating speed [rpm]  
 $\text{prop.delay}$  = propagation delay [seconds]

Note: since the propagation delay is known, it can be automatically compensated by the control unit processing the data from the AS5046.

## 21.6 Internal Timing Tolerance

The AS5046 does not require an external ceramic resonator or quartz. All internal clock timings for the AS5046 are generated by an on-chip RC oscillator. This oscillator is factory trimmed to ±5% accuracy at room temperature (±10% over full temperature range). This tolerance influences the ADC sampling rate:

### 21.6.1 Absolute Output; Serial Interface

A new angular value is updated every  
 96µs +/- 5% (Mode = 1) or  
 384µs +/- 5% (Mode = 0 or open)

## 21.7 Temperature

### 21.7.1 Magnetic Temperature Coefficient

One of the major benefits of the AS5046 compared to linear Hall sensors is that it is much less sensitive to temperature. While linear Hall sensors require a compensation of the magnet's temperature coefficients, the AS5046 automatically compensates for the varying magnetic field strength over temperature. The magnet's temperature drift does not need to be considered, as the AS5046 operates with magnetic field strengths from ±45...±75mT.

*Example:*

A NdFeB magnet has a field strength of 75mT @ -40°C and a temperature coefficient of -0.12% per Kelvin. The temperature change is from -40° to +125° = 165K.

The magnetic field change is: 165 x -0.12% = -19.8%, which corresponds to 75mT at -40°C and 60mT at 125°C .

The AS5046 can compensate for this temperature related field strength change automatically, no user adjustment is required.

### 21.7.2 Accuracy over Temperature

The influence of temperature in the absolute accuracy is very low. While the accuracy is  $\leq \pm 0.5^\circ$  at room temperature, it may increase to  $\leq \pm 0.9^\circ$  due to increasing noise at high temperatures.

### 21.7.3 Timing Tolerance over Temperature

The internal RC oscillator is factory trimmed to  $\pm 5\%$ . Over temperature, this tolerance may increase to  $\pm 10\%$ . Generally, the timing tolerance has no influence in the accuracy or resolution of the system, as it is used mainly for internal clock generation.

## 22 Package Drawings and Markings

16-Lead Shrink Small Outline Package SSOP-16

Figure 27 Package Drawings and Marking

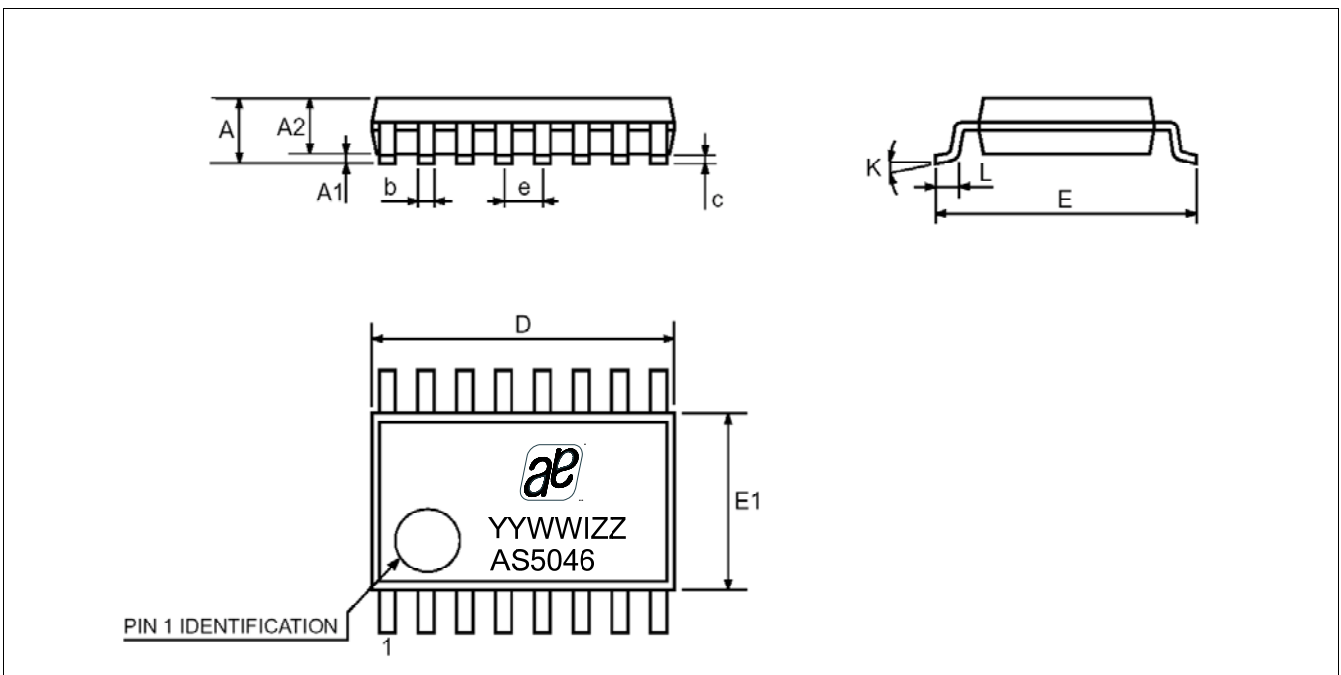



Table 25 SSOP-16 Mechanical Dimensions

Dimensions						
Symbol	mm			inch		
	Min	Typ	Max	Min	Typ	Max
A	1.73	1.86	1.99	.068	.073	.078
A1	0.05	0.13	0.21	.002	.005	.008
A2	1.68	1.73	1.78	.066	.068	.070
b	0.25	0.315	0.38	.010	.012	.015
c	0.09	-	0.20	.004	-	.008
D	6.07	6.20	6.33	.239	.244	.249
E	7.65	7.8	7.9	.301	.307	.311
E1	5.2	5.3	5.38	.205	.209	.212
e	0.65			.0256		
K	0°	-	8°	0°	-	8°
L	0.63	0.75	0.95	.025	.030	.037

**Marking: YYWWIZZ**

Y: Last Digit of Manufacturing Year  
 WW: Manufacturing Week  
 I: Plant Identifier  
 ZZ: Traceability Code

JEDEC Package Outline Standard:  
 MO - 150 AC

Thermal Resistance  $R_{th(j-a)}$ :  
 typ. 151 K/W in still air, soldered on PCB

IC's marked with a white dot or the letters "ES" denote Engineering samples

## 23 Packing Options

Delivery:           Tape and Reel (1 reel = 2000 devices)  
                       Tubes (1 box = 100 tubes á 77 devices)

Order # AS5046ASSU   for delivery in tubes  
 Order # AS5046ASST   for delivery in tape and reel

## 24 Recommended PCB Footprint

Figure 28 Recommended PCB Footprint

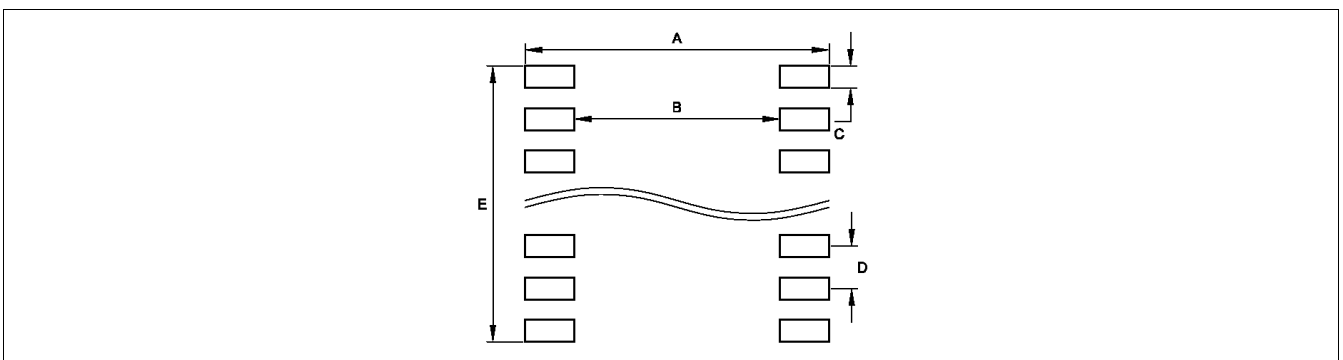

Recommended Footprint Data		
	mm	inch
A	9.02	0.355
B	6.16	0.242
C	0.46	0.018
D	0.65	0.025
E	5.01	0.197

## Copyrights

Copyright © 1997-2010, austriamicrosystems AG, Schloss Premstaetten, 8141 Unterpremstaetten, Austria-Europe. Trademarks Registered ®. All rights reserved. The material herein may not be reproduced, adapted, merged, translated, stored, or used without the prior written consent of the copyright owner.

All products and companies mentioned are trademarks or registered trademarks of their respective companies.

## Disclaimer

Devices sold by austriamicrosystems AG are covered by the warranty and patent indemnification provisions appearing in its Term of Sale. austriamicrosystems AG makes no warranty, express, statutory, implied, or by description regarding the information set forth herein or regarding the freedom of the described devices from patent infringement. austriamicrosystems AG reserves the right to change specifications and prices at any time and without notice. Therefore, prior to designing this product into a system, it is necessary to check with austriamicrosystems AG for current information. This product is intended for use in normal commercial applications. Applications requiring extended temperature range, unusual environmental requirements, or high reliability applications, such as military, medical life-support or lifesustaining equipment are specifically not recommended without additional processing by austriamicrosystems AG for each application.

The information furnished here by austriamicrosystems AG is believed to be correct and accurate. However, austriamicrosystems AG shall not be liable to recipient or any third party for any damages, including but not limited to personal injury, property damage, loss of profits, loss of use, interruption of business or indirect, special, incidental or consequential damages, of any kind, in connection with or arising out of the furnishing, performance or use of the technical data herein. No obligation or liability to recipient or any third party shall arise or flow out of austriamicrosystems AG rendering of technical or other services.



## Contact Information

### Headquarters

austriamicrosystems AG  
A-8141 Schloss Premstaetten, Austria  
Tel: +43 (0) 3136 500 0  
Fax: +43 (0) 3136 525 01

For Sales Offices, Distributors and Representatives, please visit:

<http://www.austriamicrosystems.com/contact>