

# ECX-5735-28.6363M TR

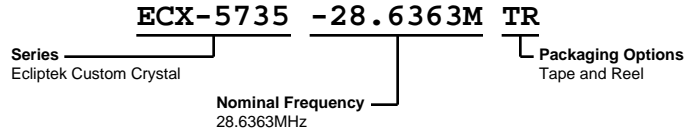

**PLEASE NOTE:** Due to the inherent proprietary nature of custom part numbers, certain parameters are intentionally excluded from this specification sheet.



## ELECTRICAL SPECIFICATIONS

Nominal Frequency	28.6363MHz
-------------------	------------

## ENVIRONMENTAL & MECHANICAL SPECIFICATIONS

Fine Leak Test	MIL-STD-883, Method 1014 Condition A
Gross Leak Test	MIL-STD-883, Method 1014 Condition C
Mechanical Shock	MIL-STD-202, Method 213 Condition C
Resistance to Soldering Heat	MIL-STD-202, Method 210
Resistance to Solvents	MIL-STD-202, Method 215
Solderability	MIL-STD-883, Method 2003
Temperature Cycling	MIL-STD-883, Method 1010
Vibration	MIL-STD-883, Method 2007 Condition A

## MECHANICAL DIMENSIONS (all dimensions in millimeters)

LINE	MARKING
1	ECX5735

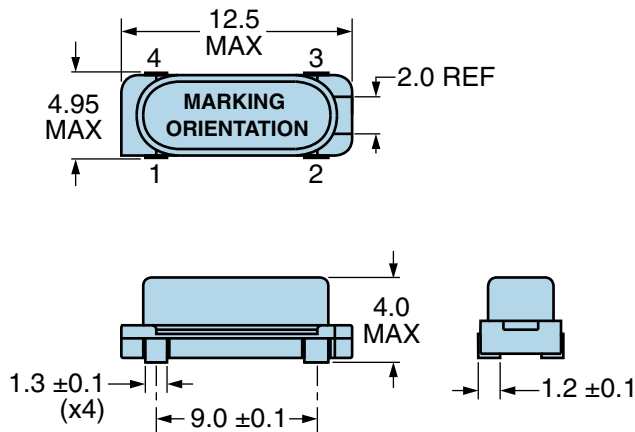

# ECX-5735-28.6363M TR

## Suggested Solder Pad Layout

All Dimensions in Millimeters

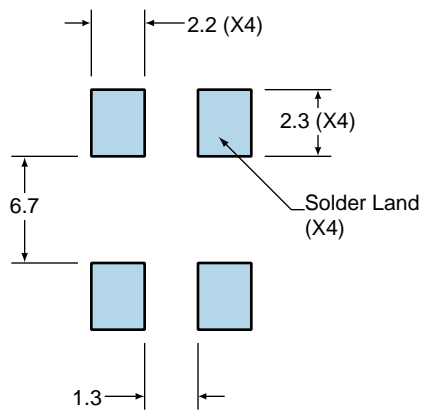

All Tolerances are  $\pm 0.1$

# ECX-5735-28.6363M TR



## Tape & Reel Dimensions

Quantity Per Reel: 1,000 units

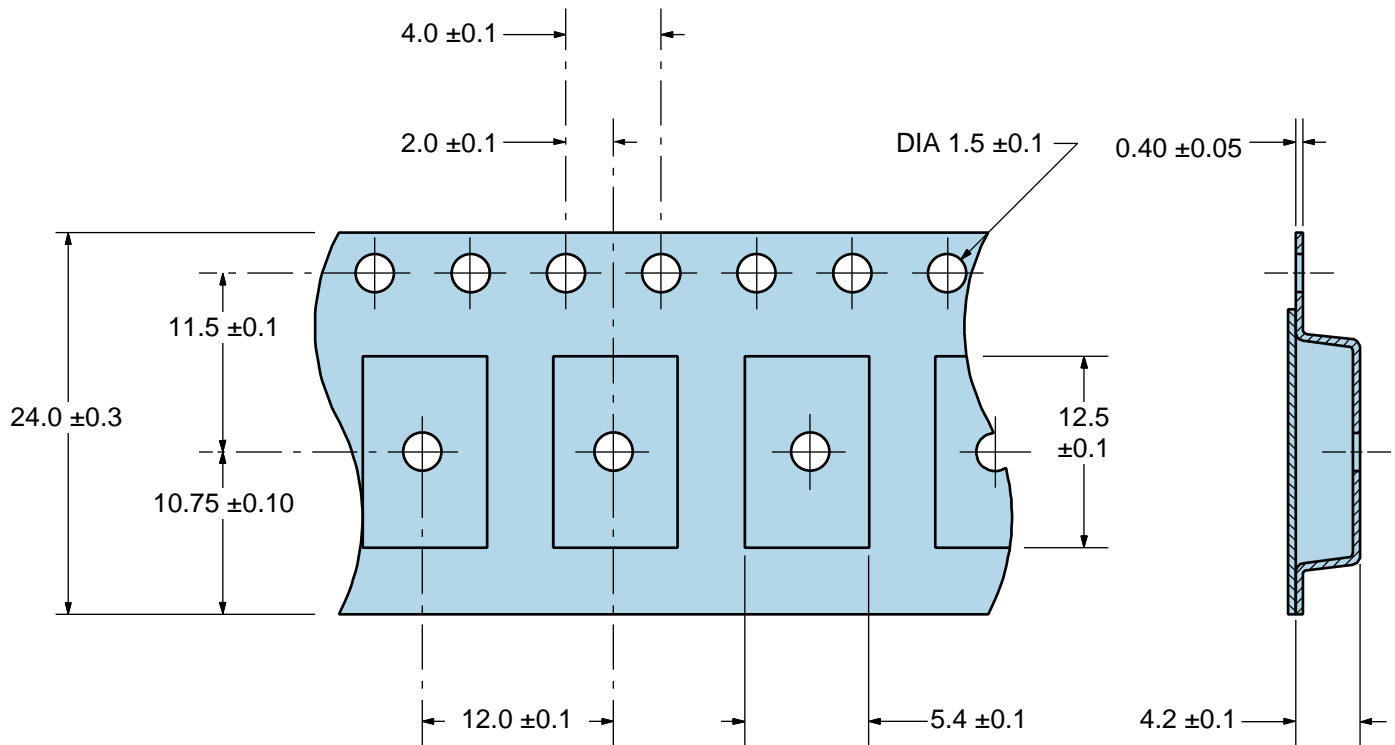

\*Compliant to EIA 481A

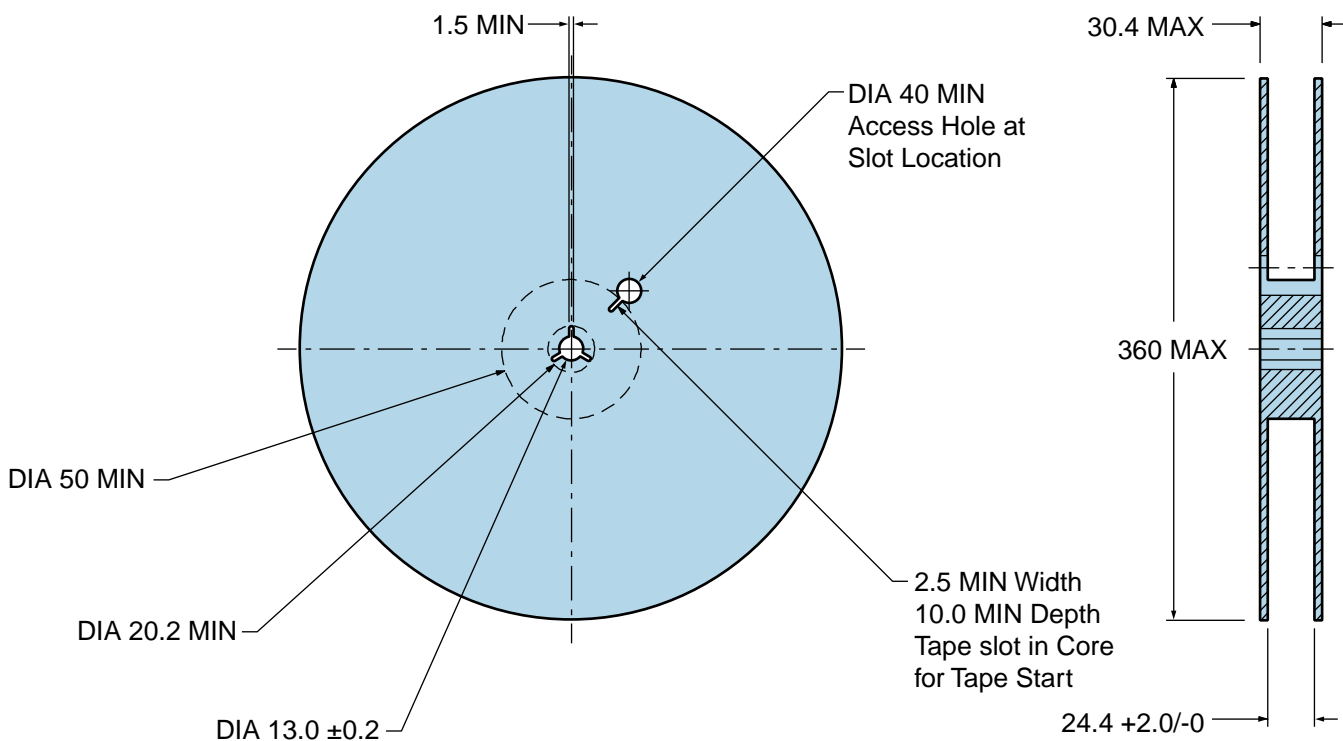

## Recommended Solder Reflow Methods



### Low Temperature Infrared/Convection 225°C

$T_S$  MAX to  $T_L$  (Ramp-up Rate) 5°C/second Maximum

#### Preheat

- Temperature Minimum ( $T_S$  MIN) N/A
- Temperature Typical ( $T_S$  TYP) 150°C
- Temperature Maximum ( $T_S$  MAX) N/A
- Time ( $t_s$  MIN) 30 - 60 Seconds

Ramp-up Rate ( $T_L$  to  $T_P$ ) 5°C/second Maximum

#### Time Maintained Above:

- Temperature ( $T_L$ ) 150°C
- Time ( $t_L$ ) 200 Seconds Maximum

Peak Temperature ( $T_P$ ) 225°C Maximum

Target Peak Temperature ( $T_P$  Target) 225°C Maximum 2 Times

Time within 5°C of actual peak ( $t_p$ ) 80 seconds Maximum 2 Times

Ramp-down Rate 5°C/second Maximum

Time 25°C to Peak Temperature (t) N/A

Moisture Sensitivity Level Level 1

### Low Temperature Manual Soldering

185°C Maximum for 10 seconds Maximum, 2 times Maximum.

### High Temperature Manual Soldering

260°C Maximum for 5 seconds Maximum, 2 times Maximum.