

# EH3620TS-12.000M TR

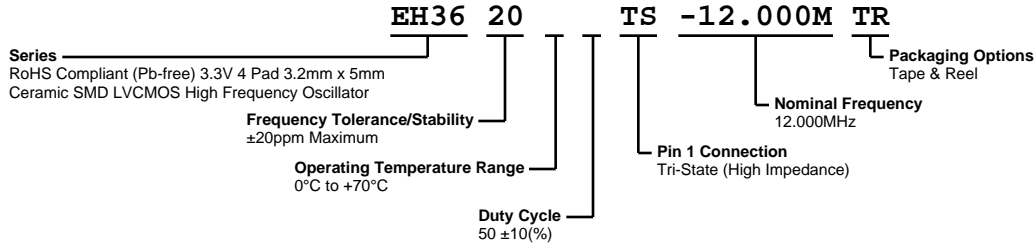

## ELECTRICAL SPECIFICATIONS

|                                       |  |
|---------------------------------------|--|
| Nominal Frequency                     | 12.000MHz  |
| Frequency Tolerance/Stability         | $\pm 20$ ppm Maximum (Inclusive of all conditions: Calibration Tolerance at $25^{\circ}\text{C}$ , Frequency Stability over the Operating Temperature Range, Supply Voltage Change, Output Load Change, 1st Year Aging at $25^{\circ}\text{C}$ , Shock, and Vibration) |
| Aging at $25^{\circ}\text{C}$         | $\pm 5$ ppm/year Maximum   |
| Operating Temperature Range           | $0^{\circ}\text{C}$ to $+70^{\circ}\text{C}$   |
| Supply Voltage                        | 3.3Vdc $\pm 0.3$ Vdc   |
| Input Current                         | 35mA Maximum (No Load)   |
| Output Voltage Logic High (Voh)       | 2.7Vdc Minimum (IOH = -8mA)  |
| Output Voltage Logic Low (Vol)        | 0.5Vdc Maximum (IOL = +8mA)  |
| Rise/Fall Time                        | 6nSec Maximum (Measured at 20% to 80% of waveform)   |
| Duty Cycle                            | $50 \pm 10(\%)$ (Measured at 50% of waveform)  |
| Load Drive Capability                 | 30pF Maximum   |
| Output Logic Type                     | CMOS   |
| Pin 1 Connection                      | Tri-State (High Impedance)   |
| Tri-State Input Voltage (Vih and Vil) | 70% of Vdd Minimum to enable output, 20% of Vdd Maximum to disable output, No Connect to enable output.  |
| Absolute Clock Jitter                 | $\pm 250$ pSec Maximum, $\pm 100$ pSec Typical   |
| One Sigma Clock Period Jitter         | $\pm 50$ pSec Maximum, $\pm 40$ pSec Typical   |
| Start Up Time                         | 10mSec Maximum   |
| Storage Temperature Range             | $-55^{\circ}\text{C}$ to $+125^{\circ}\text{C}$  |

## ENVIRONMENTAL & MECHANICAL SPECIFICATIONS

|                              |                                       |
|------------------------------|---------------------------------------|
| Fine Leak Test               | MIL-STD-883, Method 1014, Condition A |
| Gross Leak Test              | MIL-STD-883, Method 1014, Condition C |
| Mechanical Shock             | MIL-STD-202, Method 213, Condition C  |
| Resistance to Soldering Heat | MIL-STD-202, Method 210               |
| Resistance to Solvents       | MIL-STD-202, Method 215               |
| Solderability                | MIL-STD-883, Method 2003              |
| Temperature Cycling          | MIL-STD-883, Method 1010              |
| Vibration                    | MIL-STD-883, Method 2007, Condition A |

# EH3620TS-12.000M TR

## MECHANICAL DIMENSIONS (all dimensions in millimeters)

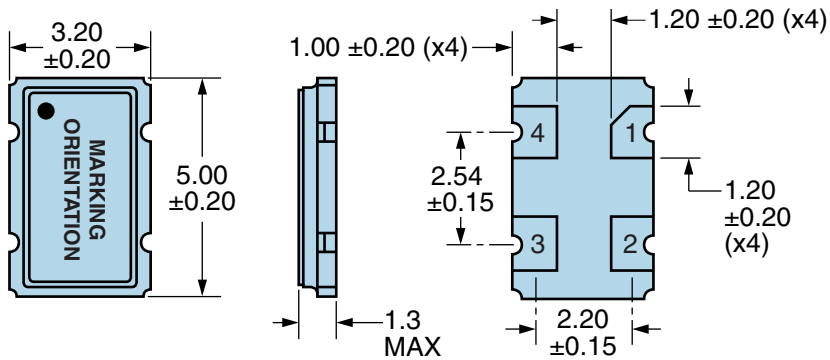

| PIN | CONNECTION         |
|-----|--------------------|
| 1   | Tri-State          |
| 2   | Ground/Case Ground |
| 3   | Output             |
| 4   | Supply Voltage     |

| LINE | MARKING                                 |
|------|---|
| 1    | <b>E12.000</b><br>E=Ecliptek Designator |

## Suggested Solder Pad Layout

All Dimensions in Millimeters



All Tolerances are  $\pm 0.1$

# EH3620TS-12.000M TR

## OUTPUT WAVEFORM & TIMING DIAGRAM



## Test Circuit for CMOS Output



Note 1: An external 0.1 $\mu$ F low frequency tantalum bypass capacitor in parallel with a 0.01 $\mu$ F high frequency ceramic bypass capacitor close to the package ground and  $V_{DD}$  pin is required.

Note 2: A low capacitance (<12pF), 10X attenuation factor, high impedance (>10Mohms), and high bandwidth (>300MHz) passive probe is recommended.

Note 3: Capacitance value  $C_L$  includes sum of all probe and fixture capacitance.

# EH3620TS-12.000M TR

## Tape & Reel Dimensions

Quantity Per Reel: 1,000 units

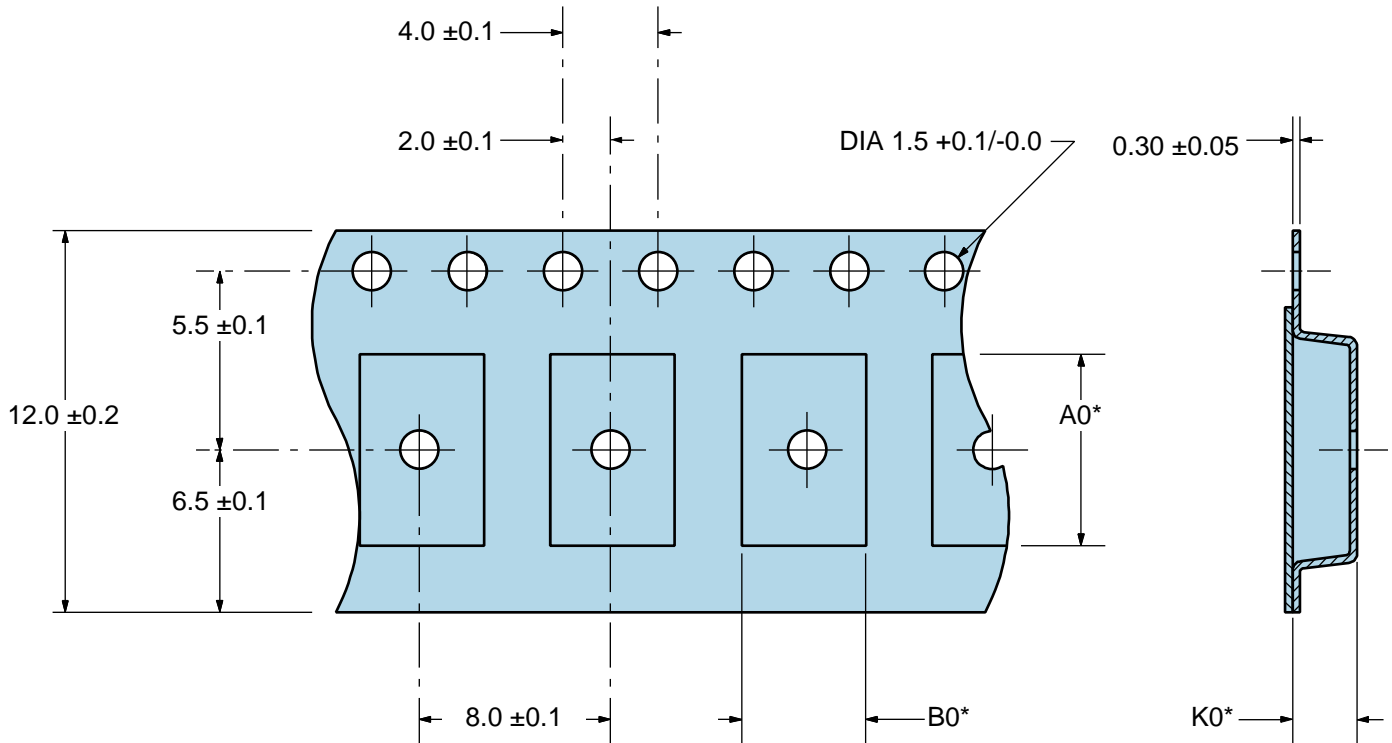

\*Compliant to EIA 481A

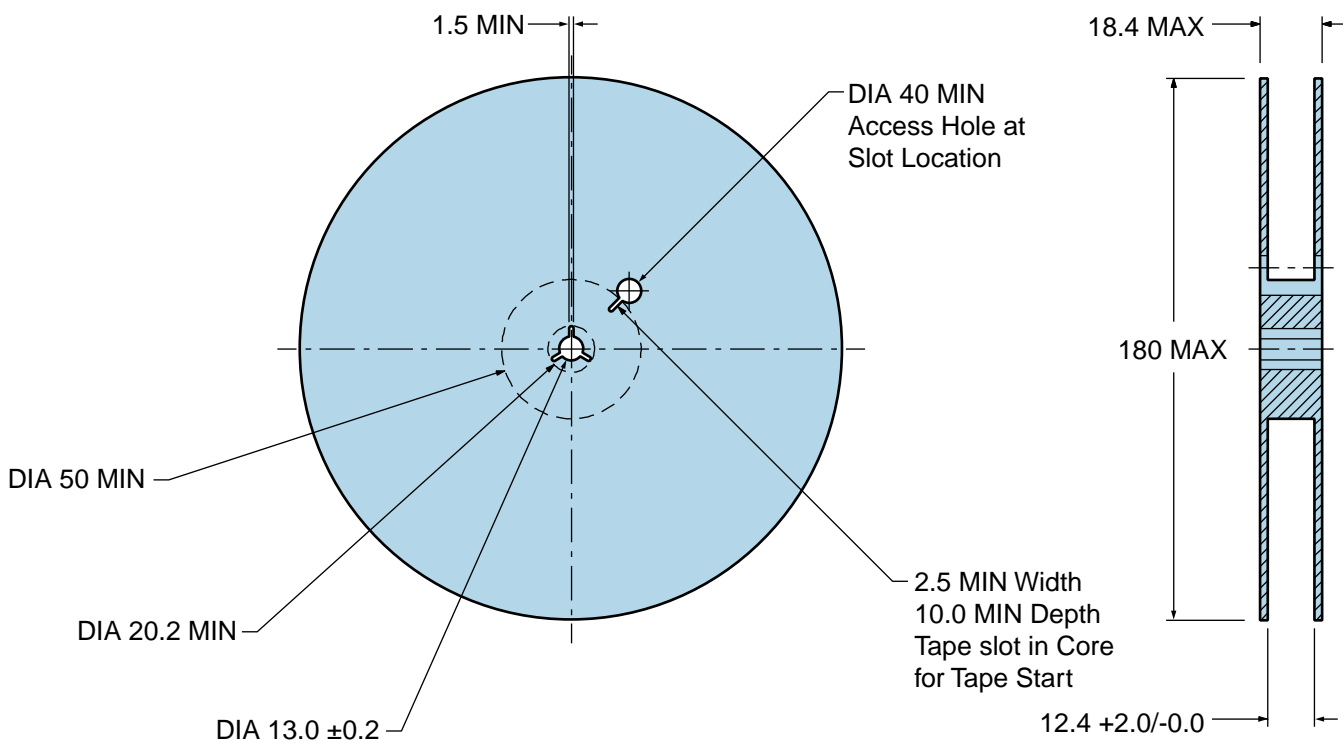

## Recommended Solder Reflow Methods



### High Temperature Infrared/Convection

|  |                                      |
|--|--------------------------------------|
| <b><math>T_s</math> MAX to <math>T_L</math> (Ramp-up Rate)</b> | 3°C/second Maximum                   |
| <b>Preheat</b>   |                                      |
| - Temperature Minimum ( $T_s$ MIN)                             | 150°C                                |
| - Temperature Typical ( $T_s$ TYP)                             | 175°C                                |
| - Temperature Maximum ( $T_s$ MAX)                             | 200°C                                |
| - Time ( $t_s$ MIN)  | 60 - 180 Seconds                     |
| <b>Ramp-up Rate (<math>T_L</math> to <math>T_p</math>)</b>     | 3°C/second Maximum                   |
| <b>Time Maintained Above:</b>                                  |                                      |
| - Temperature ( $T_L$ )  | 217°C                                |
| - Time ( $t_L$ )   | 60 - 150 Seconds                     |
| <b>Peak Temperature (<math>T_p</math>)</b>                     | 260°C Maximum for 10 Seconds Maximum |
| <b>Target Peak Temperature (<math>T_p</math> Target)</b>       | 250°C +0/-5°C                        |
| <b>Time within 5°C of actual peak (<math>t_p</math>)</b>       | 20 - 40 seconds                      |
| <b>Ramp-down Rate</b>  | 6°C/second Maximum                   |
| <b>Time 25°C to Peak Temperature (t)</b>                       | 8 minutes Maximum                    |
| <b>Moisture Sensitivity Level</b>                              | Level 1                              |

## Recommended Solder Reflow Methods



### Low Temperature Infrared/Convection 240°C

|  |  |
|--|--|
| <b><math>T_s</math> MAX to <math>T_L</math> (Ramp-up Rate)</b> | 5°C/second Maximum                                     |
| <b>Preheat</b>   |  |
| - Temperature Minimum ( $T_s$ MIN)                             | N/A  |
| - Temperature Typical ( $T_s$ TYP)                             | 150°C  |
| - Temperature Maximum ( $T_s$ MAX)                             | N/A  |
| - Time ( $t_s$ MIN)  | 60 - 120 Seconds                                       |
| <b>Ramp-up Rate (<math>T_L</math> to <math>T_p</math>)</b>     | 5°C/second Maximum                                     |
| <b>Time Maintained Above:</b>                                  |  |
| - Temperature ( $T_L$ )  | 150°C  |
| - Time ( $t_L$ )   | 200 Seconds Maximum                                    |
| <b>Peak Temperature (<math>T_p</math>)</b>                     | 240°C Maximum  |
| <b>Target Peak Temperature (<math>T_p</math> Target)</b>       | 240°C Maximum 1 Time / 230°C Maximum 2 Times           |
| <b>Time within 5°C of actual peak (<math>t_p</math>)</b>       | 10 seconds Maximum 2 Times / 80 seconds Maximum 1 Time |
| <b>Ramp-down Rate</b>  | 5°C/second Maximum                                     |
| <b>Time 25°C to Peak Temperature (t)</b>                       | N/A  |
| <b>Moisture Sensitivity Level</b>                              | Level 1  |

### Low Temperature Manual Soldering

185°C Maximum for 10 seconds Maximum, 2 times Maximum.

### High Temperature Manual Soldering

260°C Maximum for 5 seconds Maximum, 2 times Maximum.