

High Isolation Gate Drive Transformers

PH9400.XXXNL and PH9400.XXXANL - SMT

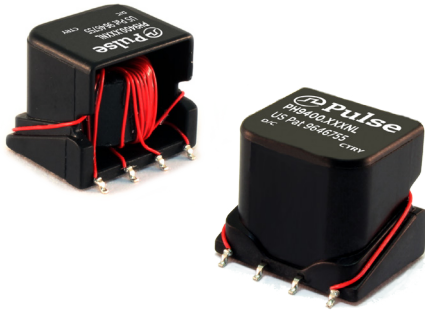

- Basic and Reinforced Insulation
- Sidecar package with 12mm creepage
- Up to 5000Vrms gate to drive isolation
- 1000Vrms continuous isolation between windings
- Up to 8W of Driver Power
- Patented:** US Patent 9,646,755

Electrical Specifications @ 25°C - Operating Temperature -40°C to +125°C

| Part Number | Turns Ratio | ET (1-4) (V * μsec MAX) | Core Loss Factor K1 | Primary Inductance (1-4) (mH +/-35%) | Leakage Inductance Drive to Gate (μH MAX) | Parasitic Capacitance Drive to Gate (pF MAX) | DCR Drive (1-4) (Ω MAX) | DCR Gates (5-6) (7-8) (Ω MAX) | Hi-Pot | |
|--|-------------|----------------------------|---------------------|---|--|---|----------------------------|-------------------------------------|-------------------|------------------|
| | | | | | | | | | Drive-Gate (Vrms) | Gate-Gate (Vrms) |
| PH9400.XXXNL - Basic Insulation 600Vrms continuous isolation | | | | | | | | | | |
| PH9400.111NL | 1:1:1 | 315 | 0.67 | 4.5 | 5.0 | 60 | 1.8 | 2.5 | 4000 | 1500 |
| PH9400.566NL | 5:6:6 | 315 | 0.67 | 4.5 | 3.5 | 60 | 1.8 | 3.0 | 4000 | 1500 |
| PH9400.122NL | 1:2:2 | 250 | 0.84 | 2.88 | 3.5 | 60 | 1.5 | 4.2 | 4000 | 1500 |
| PH9400.655NL | 6:5:5 | 375 | 0.56 | 6.48 | 5.3 | 60 | 2.2 | 2.5 | 4000 | 1500 |
| PH9400.211NL | 2:1:1 | 375 | 0.56 | 6.48 | 8.0 | 60 | 2.2 | 1.6 | 4000 | 1500 |
| PH9400.XXXANL - Reinforced Insulation 1000Vrms continuous isolation | | | | | | | | | | |
| PH9400.111ANL | 1:1:1 | 160 | 1.32 | 1.21 | 2.5 | 45 | 0.9 | 0.9 | 5000 | 2000 |
| PH9400.566ANL | 5:6:6 | 155 | 1.36 | 1.12 | 3.0 | 45 | 0.9 | 1.0 | 5000 | 2000 |
| PH9400.233ANL | 2:3:3 | 125 | 1.68 | 0.72 | 2.0 | 45 | 0.7 | 1.0 | 5000 | 2000 |
| PH9400.655ANL | 6:5:5 | 185 | 1.14 | 1.62 | 3.0 | 45 | 1.0 | 0.9 | 5000 | 2000 |
| PH9400.211ANL | 2:1:1 | 185 | 1.14 | 1.62 | 3.5 | 45 | 1.0 | 0.55 | 5000 | 2000 |

Notes:

- The max ET is calculated to limit the core loss and temperature rise at 100kHz based on a bipolar flux swing of 2100Ga Peak. This value needs to be derated for higher frequencies using the temperature rise calculation.
- The temperature rise of the component is calculated based on the total core loss and copper loss:
 - To calculate total copper loss (W), use the following formula:
Copper Loss (W) = $I_{rms}^2 * (DCR_Drive + (\# \text{ of Gates}) * DCR_Gates)$
 - To calculate total core loss (W), use the following formula:
Copper Loss (W) = $5.1E-10 * (\text{Frequency in kHz})^{1.42} * (K1 * ET)^{2.5}$
Where ET = $(V * \text{Duty Cycle}) / \text{Frequency}$
 - To calculate temperature rise, use the following formula:
Temperature Rise (°C) = $71 * (\text{Core Loss}(W) + \text{Copper Loss}(W))$
- Continuous isolation voltage confirmed by 125°C/1000hrs accelerated aging with the bias voltage applied between gate and drive windings.
- ANL versions, which use triple insulated wire on both the drive and gate windings, are compliant with IEC 60950, IEC 61558, IEC 61010 & IEC 60601 for reinforced insulation.
NL versions, which use triple insulated wire on just the drive winding, comply with basic insulation requirements.
- 12mm package creepage distance satisfies IEC60950-1 & IEC61558-1/-2-16 reinforced insulation requirements for working voltage to 600Vrms max, OVC II, Pollution Degree 2 and altitude up to 2000m.
- Unless otherwise specified, all testing is made at 100kHz, 0.1V_{ac}.
- Optional Tape & Reel packaging can be ordered by adding a "T" suffix to the part number (i.e. PH9400.111NL becomes PH9400.111NLT). Pulse complies to industry standard tape and reel specification EIA481.

High Isolation Gate Drive Transformers

PH9400.XXXNL and PH9400.XXXANL - SMT



Mechanicals

Schematics

PH9400.XXXNL and PH9400.XXXANL

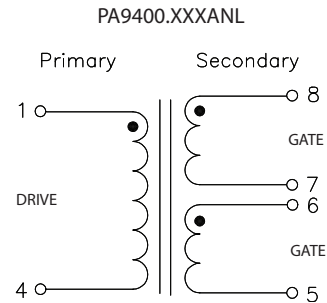
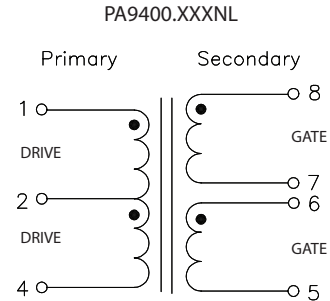
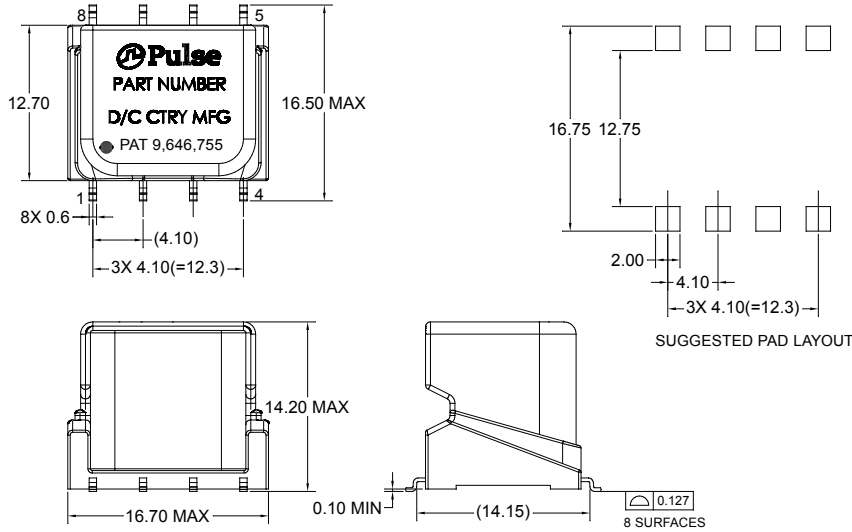

Weight2.5 grams
Tape & Reel150/Reel
Tray80/tray

Dimension: $\frac{\text{Inches}}{\text{mm}}$
 Unless otherwise specified, all tolerances are $\pm \frac{.010}{0,25}$

For More Information

Pulse Worldwide Headquarters

15255 Innovation Drive Ste 100
 San Diego, CA 92128
 U.S.A.

Pulse Europe

Pulse Electronics GmbH
 Am Rottland 12
 58540 Meinerzhagen
 Germany

Pulse China Headquarters

Pulse Electronics (ShenZhen) CO., LTD
 D708, Shenzhen Academy of
 Aerospace Technology,
 The 10th Keji South Road,
 Nanshan District, Shenzhen, P.R.
 China 518057

Pulse North China

Room 2704/2705
 Super Ocean Finance Ctr.
 2067 Yan An Road West
 Shanghai 200336
 China

Pulse South Asia

135 Joo Seng Road
 #03-02
 PM Industrial Bldg.
 Singapore 368363

Pulse North Asia

1F., No.111 Xiyuan Rd
 Zhongli City
 Taoyuan City 32057
 Taiwan (R.O.C)

Tel: 858 674 8100
 Fax: 858 674 8262

Tel: 49 2354 777 100
 Fax: 49 2354 777 168

Tel: 86 755 33966678
 Fax: 86 755 33966700

Tel: 86 21 62787060
 Fax: 86 2162786973

Tel: 65 6287 8998
 Fax: 65 6280 0080

Tel: 886 3 4356768
 Fax: 886 3 4356820

Performance warranty of products offered on this data sheet is limited to the parameters specified. Data is subject to change without notice. Other brand and product names mentioned herein may be trademarks or registered trademarks of their respective owners. © Copyright, 2017. Pulse Electronics, Inc. All rights reserved.