

RECOMMENDED PCB LAYOUT

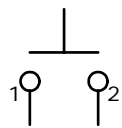

▲ CIRCUIT: SPST

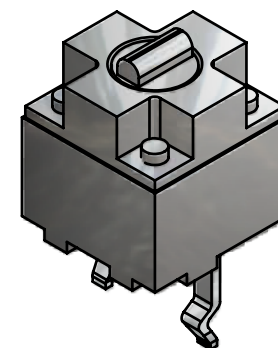
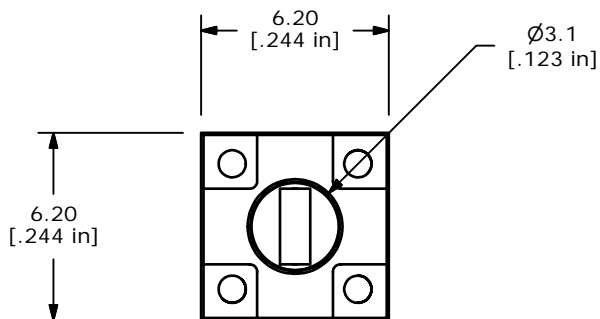

ISOMETRIC

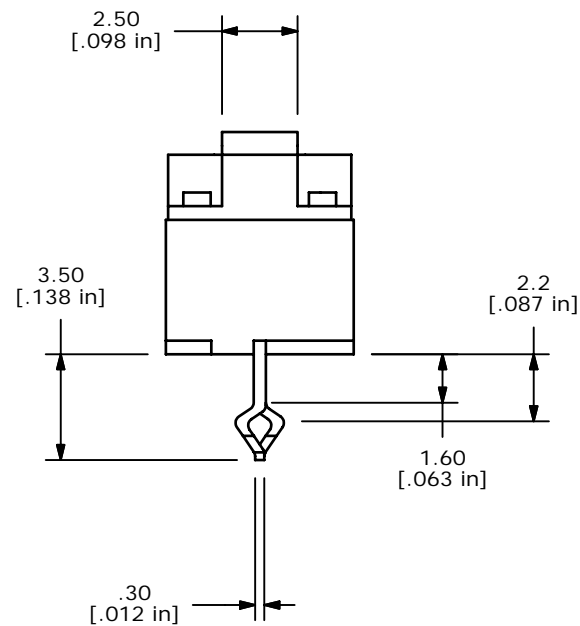
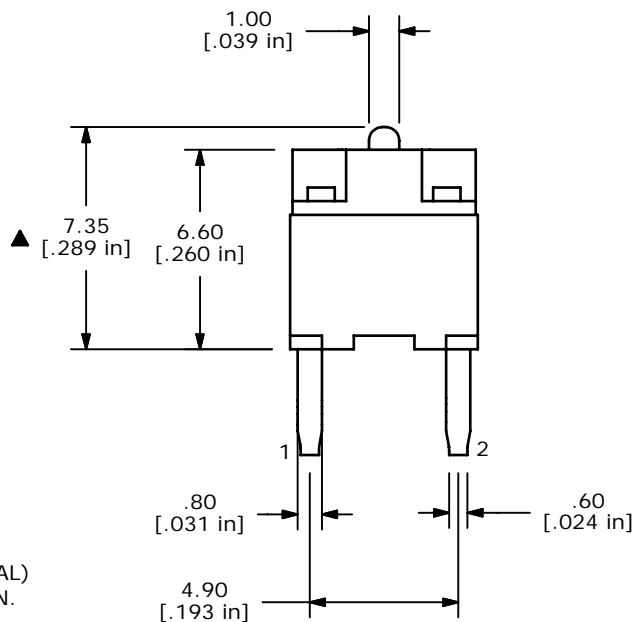

NOTES:

1. ALL DIMENSIONS IN MM
2. GENERAL TOLERANCE: X.X=±0.4
X.XX=±0.25
3. TERM. NOS. FOR REFERENCE ONLY.
4. RATING: 30VDC, 50mA
5. OPERATING FORCE: 70 ± 20 gms
6. TRAVEL: 0.35mm +/-0.2mm
7. CONTACT RESISTANCE: 100 MILLI OHMS MAX. (INITIAL)
8. MECHANICAL/ELECTRICAL LIFE 1,000,000 CYCLES MIN.
9. OPERATING TEMPERATURE: -25C to +85C.
10. INSULATION RESISTANCE: 100M OHMS.
11. DIELECTRIC STRENGTH: 600VAC, 1MINUTE.
12. 2002/95/EC (ROHS) COMPLIANT
13. PACKAGING: BULK
14. ▲ DENOTES CRITICAL PARAMETER

E-SWITCH®

TITLE TL1140AF070Q

A	16675	RELEASED FOR PRODUCTION	11/17/2006	TN
REV	PCR NO	DESCRIPTION	DATE	BY

THE INFORMATION CONTAINED IN THIS DOCUMENT IS PROPRIETARY TO E-SWITCH AND IS NOT TO BE COPIED OR TRANSFERRED

SCALE	DATE	DR	DWG	REV
4:1	11/17/2006	TN	Q970066	A