

DO NOT SCALE FROM THIS PRINT

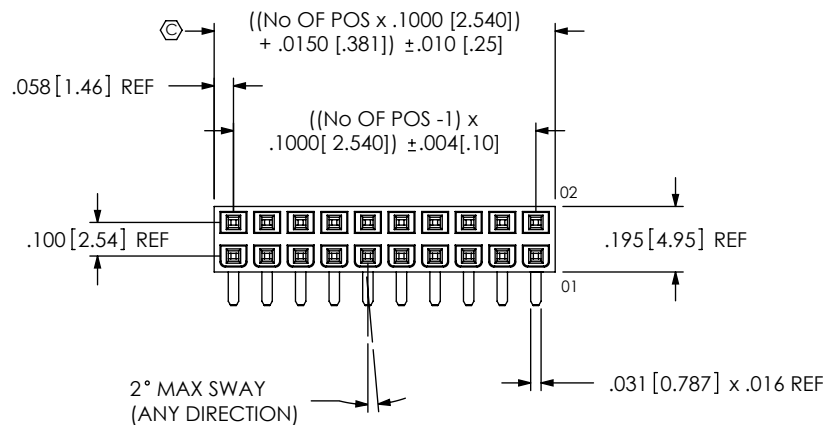

IPS1-1XX-XX-XX-D-RA-XX [P]

- No OF POS PER ROW
-02 THRU -25
- LEAD STYLE
-01
- PLATING SPECIFICATION
 -S: SELECTIVE GOLD, MATTE TIN TAILS (USE C-08-XX-S)
 -H: HEAVY GOLD (USE C-08-XX-H)
 -SM: SELECTIVE GOLD, MATTE TIN TAIL (USE C-08-XX-S)
 -L: LIGHT SELECTIVE GOLD, MATTE TIN TAIL (USE C-08-XX-L)
- OPTION
 [P] -PL: POSITION #1 REMOVED (USE IPS1-XX-D-P) (SEE NOTE 7)
 * -FL: FRICTION LOCK (USE IPS1-XX-D-FL-X) [POSITIONS -05 THRU -25]
- TAIL OPTION
-RA: RIGHT ANGLE
- ROW SPECIFICATION
-D: DOUBLE (USE IPS1-XX-D)
- * = NOT RELEASED

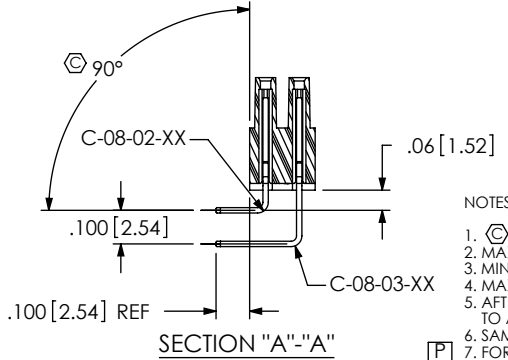
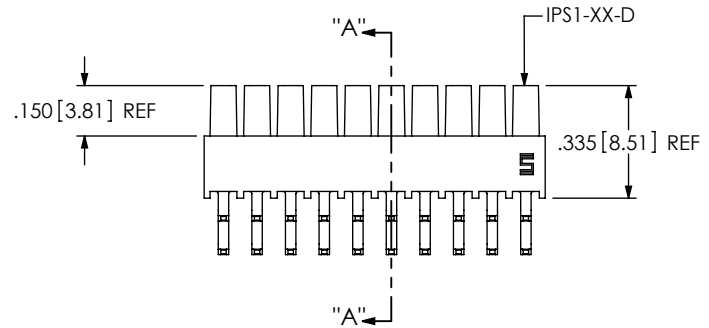

- NOTES:
1. \odot REPRESENTS A CRITICAL DIMENSION.
 2. MAXIMUM ALLOWABLE CUT FLASH: .010.
 3. MINIMUM CONTACT PUSH OUT FORCE: 1.5 lbs.
 4. MAXIMUM ALLOWABLE BOW: .003 INCH/INCH AFTER ASSEMBLY.
 5. AFTER REVISION N OF COMPONENT IPS1-XX-D-XX-X, SAMTEC LOGO TO APPEAR ON POSITION #1.
 6. SAMTEC LOGO INDICATES THE FIRST ROW TO BE FILLED FOR -RA APPLICATION.
 7. FOR EXISTING CUSTOMERS ONLY, -POL CAN BE SUBSTITUTED FOR -PL.

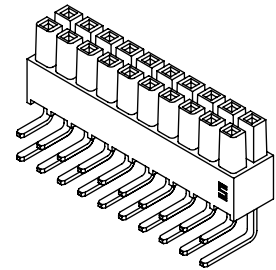

-FL: FRICTION LOCK OPTION
IPS1-110-01-X-D-RA-FL SHOWN
* NOT RELEASED

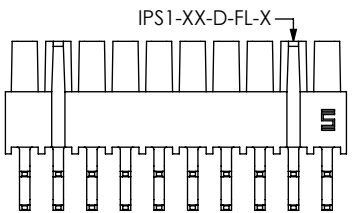

-PL: POLARIZED OPTION
IPS1-110-01-X-D-RA-PL SHOWN

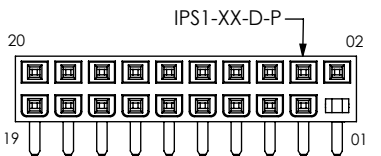

IN-PROCESS 1
(SEE NOTES 5 & 6)

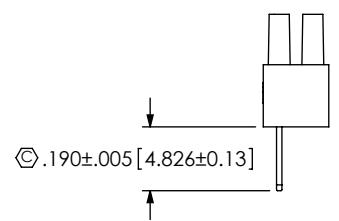

IN-PROCESS 2

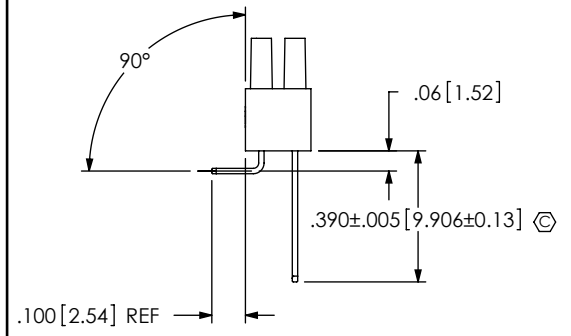

TUBE: PT-1-24-03-44
PLUG: TP-03

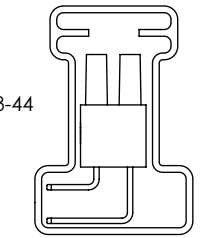

UNLESS OTHERWISE SPECIFIED, DIMENSIONS ARE IN INCHES.
TOLERANCES ARE:
DECIMALS ANGLES
.XX: $\pm .01$ $\pm 2^\circ$
.XXX: $\pm .005$
.XXXX: $\pm .0020$

PROPRIETARY NOTE
THIS DOCUMENT CONTAINS INFORMATION CONFIDENTIAL AND PROPRIETARY TO SAMTEC, INC. AND SHALL NOT BE REPRODUCED OR TRANSFERRED TO OTHER DOCUMENTS OR DISCLOSED TO OTHERS OR USED FOR ANY PURPOSE OTHER THAN THAT WHICH IT WAS OBTAINED WITHOUT THE EXPRESSED WRITTEN CONSENT OF SAMTEC, INC.



MATERIAL: DO NOT SCALE DRAWING SHEET SCALE: 1:75:1
INSULATOR: VECTRA E130i, COLOR: BLACK
CONTACT: PHOS BRONZE, 510 SPRING TEMPER

DESCRIPTION:
.100 DOUBLE ROW SHROUDED SOCKET ASSEMBLY
DWG. NO.
IPS1-1XX-XX-XX-D-RA-XXX