

DO NOT SCALE FROM THIS PRINT

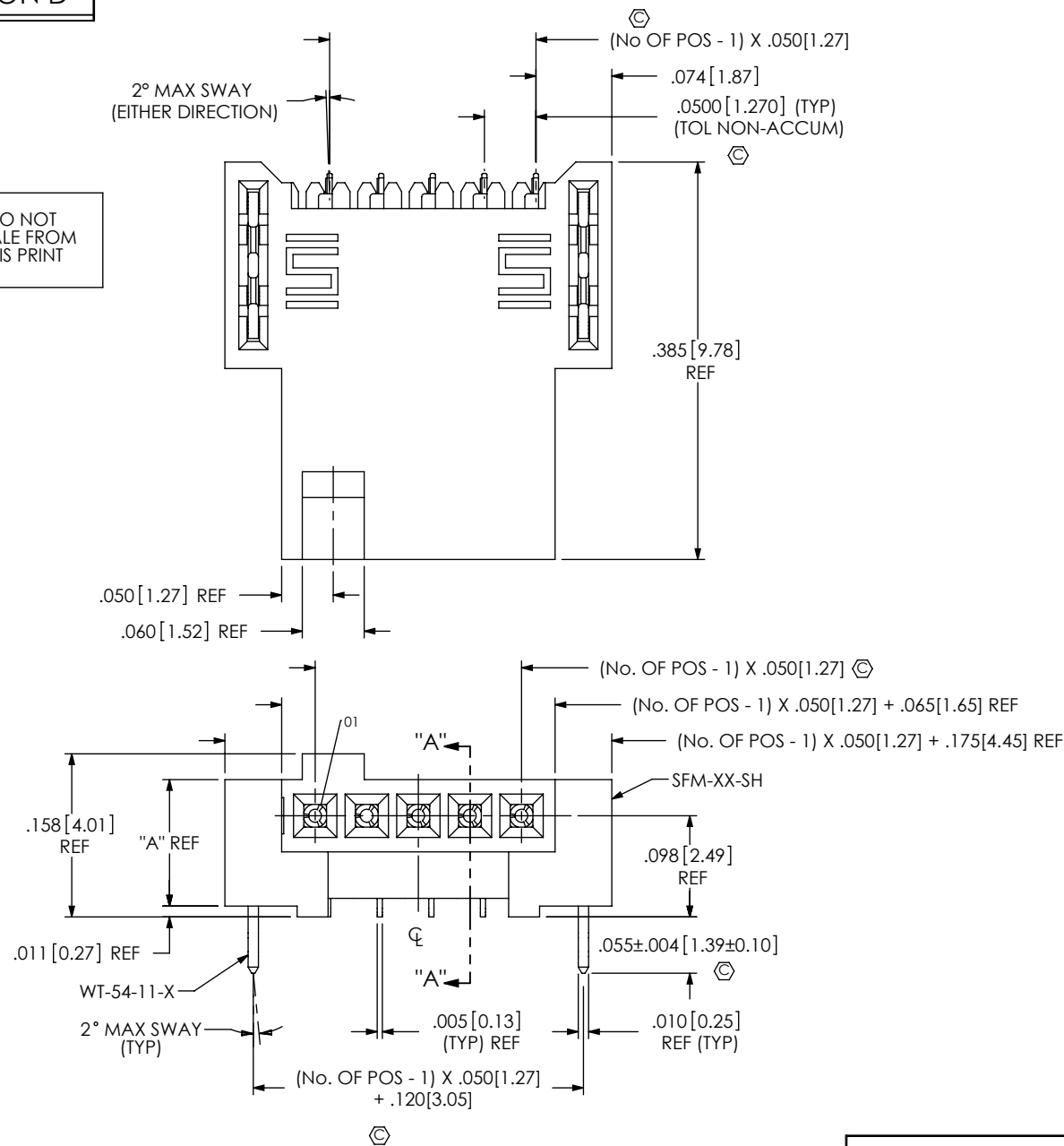

FIG 1  
SFM-105-02-X-SH SHOWN

NOTES:

1.  $\varnothing$  REPRESENTS A CRITICAL DIMENSION.
2. MAXIMUM BURR ALLOWANCE:  $.0015 [0.038]$ .
3. MINIMUM PUSHOUT FORCE:  $.5 LB.$
4. NOT RECOMMENDED FOR INVERTED REFLOW SOLDER.
5. FOR QUANTITIES UP TO 49 PIECES, NO LEADER, TRAILER, OR REEL WILL BE SUPPLIED.  
FOR QUANTITIES OF 50-124 PIECES, NO LEADER OR TRAILER WILL BE SUPPLIED.

**SFM-1XX-XX-X-XH-TR**

No OF POSITIONS  
-05 THRU -30, \*-31 THRU \*-50  
(PER ROW)

LEAD STYLE  
-02

PLATING SPECIFICATION  
-L:  $10\mu$ " SELECTIVE GOLD IN CONTACT AREA, MATTE TIN ON TAIL  
-S:  $30\mu$ " SELECTIVE GOLD IN CONTACT AREA, MATTE TIN ON TAIL

PACKAGE  
-TR: TAPE & REEL  
(SEE NOTE 5)

ROW SPECIFICATION  
-SH: SINGLE HORIZONTAL  
-DH: DOUBLE HORIZONTAL

(\* = NOT TOOLED)

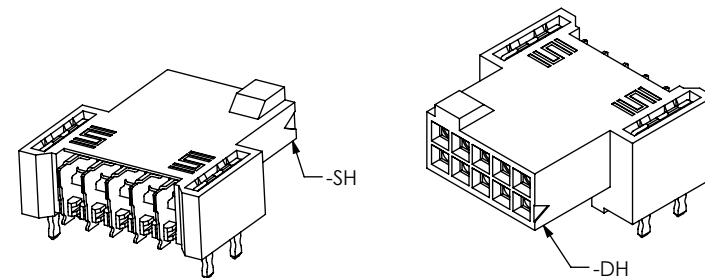

**TABLE 2**

ROW SPEC	"A"
-SH	.123 [3.12]
-DH	.173 [4.39]

**TABLE 1**

No. OF POS	$\varnothing$	—
-05 THRU -30	.004 [0.10]	.004 [0.10]
*-31 THRU *-50	.006 [0.15]	.006 [0.15]

(\* = NOT TOOLED)

UNLESS OTHERWISE SPECIFIED, DIMENSIONS ARE IN INCHES.  
TOLERANCES ARE:  
DECIMALS ANGLES  
.XX:  $\pm .01 [.]3$   $2^\circ$   
.XXX:  $\pm .005 [.]13$   
.XXXX:  $\pm .0020 [.]051$

**PROPRIETARY NOTE**  
THIS DOCUMENT CONTAINS INFORMATION CONFIDENTIAL AND PROPRIETARY TO SAMTEC, INC. AND SHALL NOT BE REPRODUCED OR TRANSFERRED TO OTHER DOCUMENTS OR DISCLOSED TO OTHERS OR USED FOR ANY PURPOSE OTHER THAN THAT WHICH IT WAS OBTAINED WITHOUT THE EXPRESSED WRITTEN CONSENT OF SAMTEC, INC.



520 PARK EAST BLVD, NEW ALBANY, IN 47150  
PHONE: 812-944-6733 FAX: 812-948-5047  
e-Mail: info@SAMTEC.com code 55322

**MATERIAL:** DO NOT SCALE DRAWING SHEET SCALE: 6:1  
INSULATOR: VECTRA E130i UL 94V-0, COLOR: BLACK  
CONTACT: PHOS BRONZE

**DESCRIPTION:** .050 x .050 SOCKET STRIP ASSEMBLY

**DWG. NO.** SFM-1XX-XX-X-XH-TR

**BY:** VICKY Z 11/22/2010 SHEET 1 OF 3

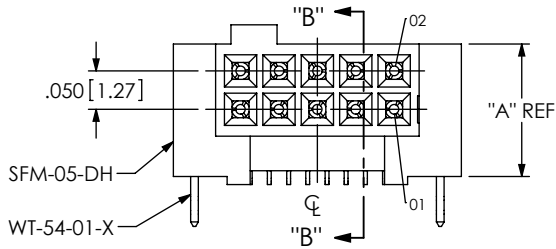
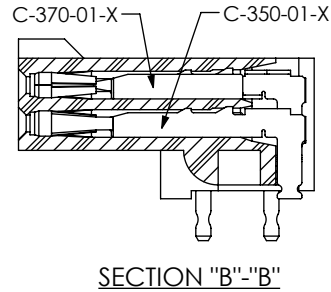
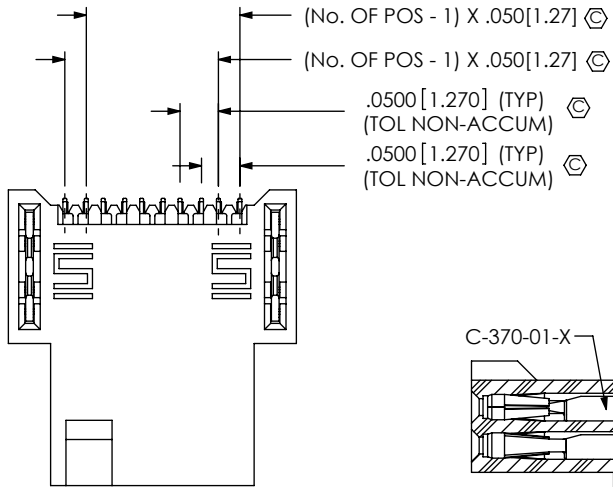
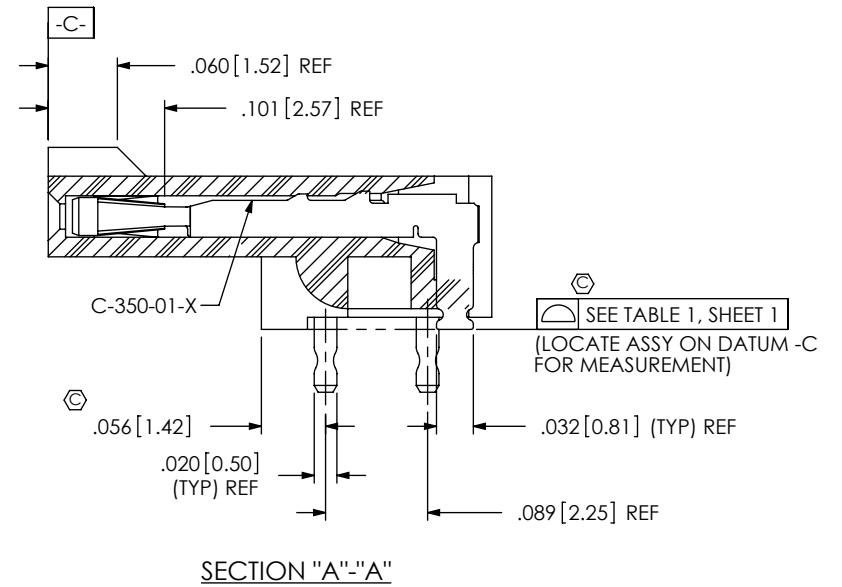

FIG 2  
 SFM-105-02-X-DH SHOWN  
 (DIFFERENT AS SHOWN, OTHERWISE SAME AS FIG 1)



PROPRIETARY NOTE  
 THIS DOCUMENT CONTAINS INFORMATION  
 CONFIDENTIAL AND PROPRIETARY TO  
 SAMTEC, INC. AND SHALL NOT BE REPRODUCED  
 OR TRANSFERRED TO OTHER DOCUMENTS OR  
 DISCLOSED TO OTHERS OR USED FOR ANY  
 PURPOSE OTHER THAN THAT WHICH IT WAS  
 OBTAINED WITHOUT THE EXPRESSED WRITTEN  
 CONSENT OF SAMTEC, INC.

DO NOT SCALE DRAWING

SHEET SCALE: 4:1

**samtec**

520 PARK EAST BLVD, NEW ALBANY, IN 47150  
 PHONE: 812-944-6733 FAX: 812-948-5047  
 e-Mail info@SAMTEC.com code 55322

DESCRIPTION:  
 .050 x .050 SOCKET STRIP ASSEMBLY

DWG. NO.  
**SFM-1XX-XX-X-XH-TR**

BY: VICKY Z 11/22/2010 SHEET 2 OF 3

IN-PROCESS 1  
FILL C-350-01-X  
(FOR -SH ONLY)

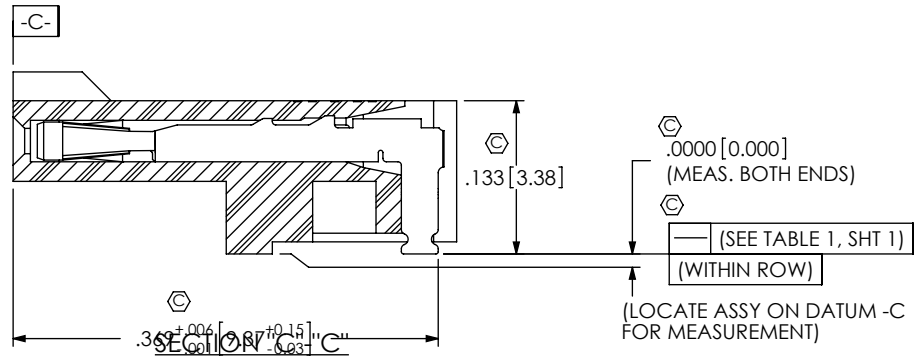
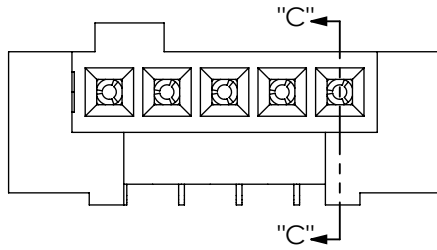

IN-PROCESS 1  
FILL C-350-01-X  
(FOR -DH ONLY)

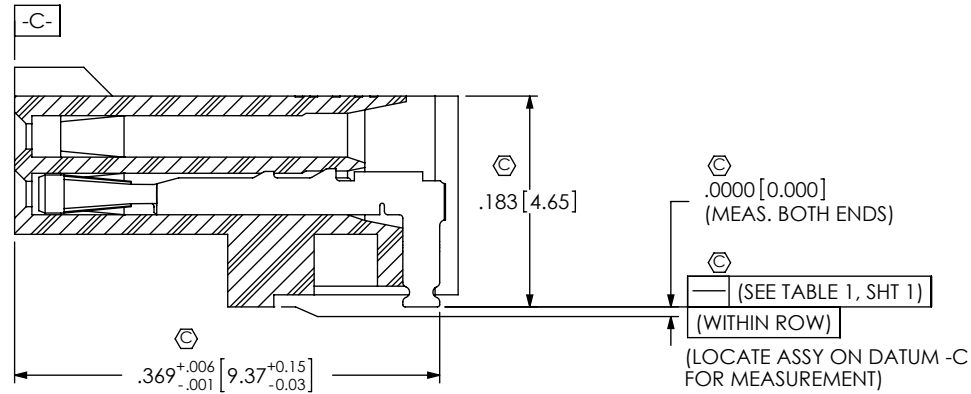
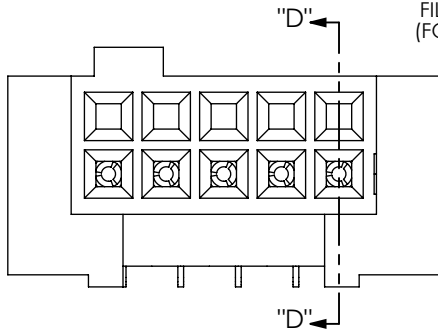

SECTION "D"- "D"

IN-PROCESS 2  
FILL C-370-01-X  
(FOR -DH ONLY)

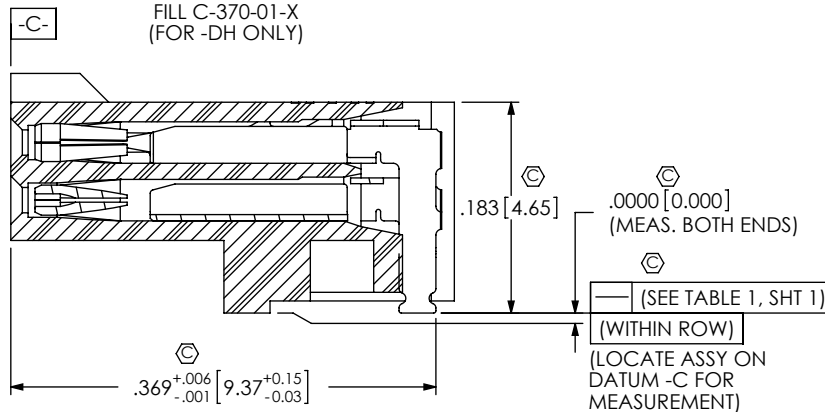
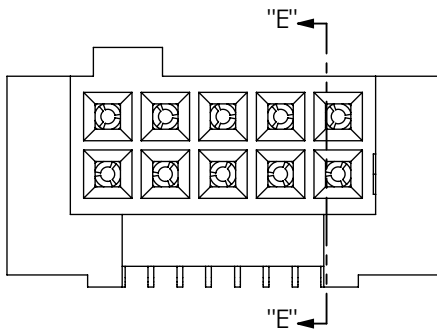

SECTION "E"- "E"

**PROPRIETARY NOTE**  
THIS DOCUMENT CONTAINS INFORMATION CONFIDENTIAL AND PROPRIETARY TO SAMTEC, INC. AND SHALL NOT BE REPRODUCED OR TRANSFERRED TO OTHER DOCUMENTS OR DISCLOSED TO OTHERS OR USED FOR ANY PURPOSE OTHER THAN THAT WHICH IT WAS OBTAINED WITHOUT THE EXPRESSED WRITTEN CONSENT OF SAMTEC, INC.

DO NOT SCALE DRAWING

SHEET SCALE: 6:1



520 PARK EAST BLVD, NEW ALBANY, IN 47150  
PHONE: 812-944-6733 FAX: 812-948-5047  
e-Mail: info@SAMTEC.com code 55322

DESCRIPTION: .050 x .050 SOCKET STRIP ASSEMBLY

DWG. NO. SFM-1XX-XX-X-XH-TR

BY: VICKY Z 11/22/2010 SHEET 3 OF 3