

DO NOT SCALE FROM THIS PRINT

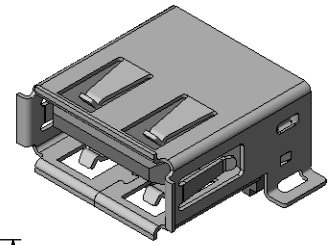
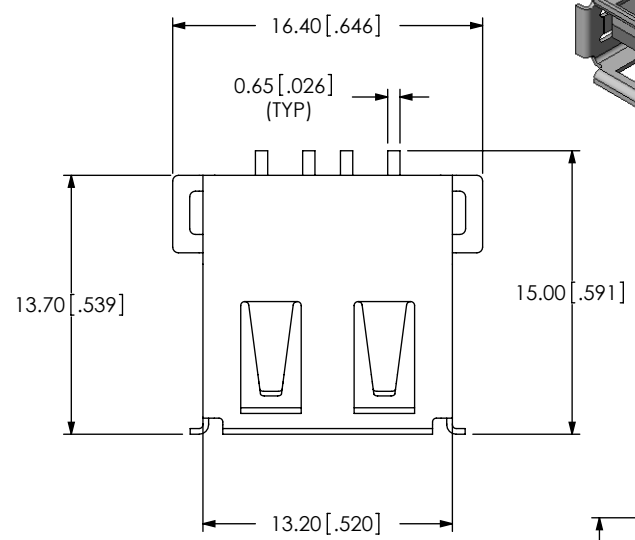

USB-A-S-X-X-SM2-X-XX

TYPE
-A

CONFIGURATION
-S: SINGLE

PLATING SPECIFICATION
C4 -F: GOLD FLASH ON MATING AREA, MATTE TIN ON TAIL
-S: SELECTIVE, .000030 GOLD ON MATING AREA, MATTE TIN ON TAIL

T&R OPTION
-TR: TAPE AND REEL (LEAVE BLANK FOR TRAY PACKAGING)

COMPLIANCE
-R: ROHS COMPLIANT (SEE NOTE 5)

TERMINATION
-SM2: SURFACE MOUNT 2

COLOR
-B: BLACK
-W: WHITE

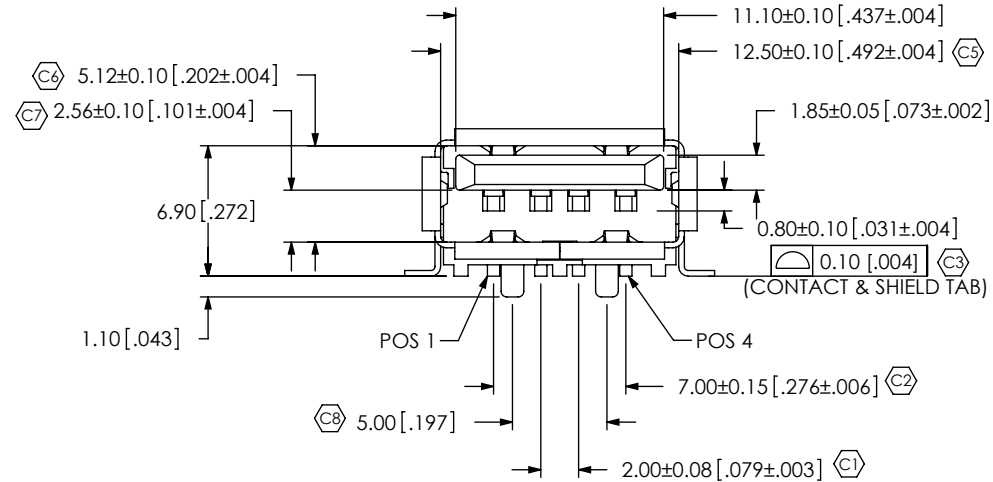
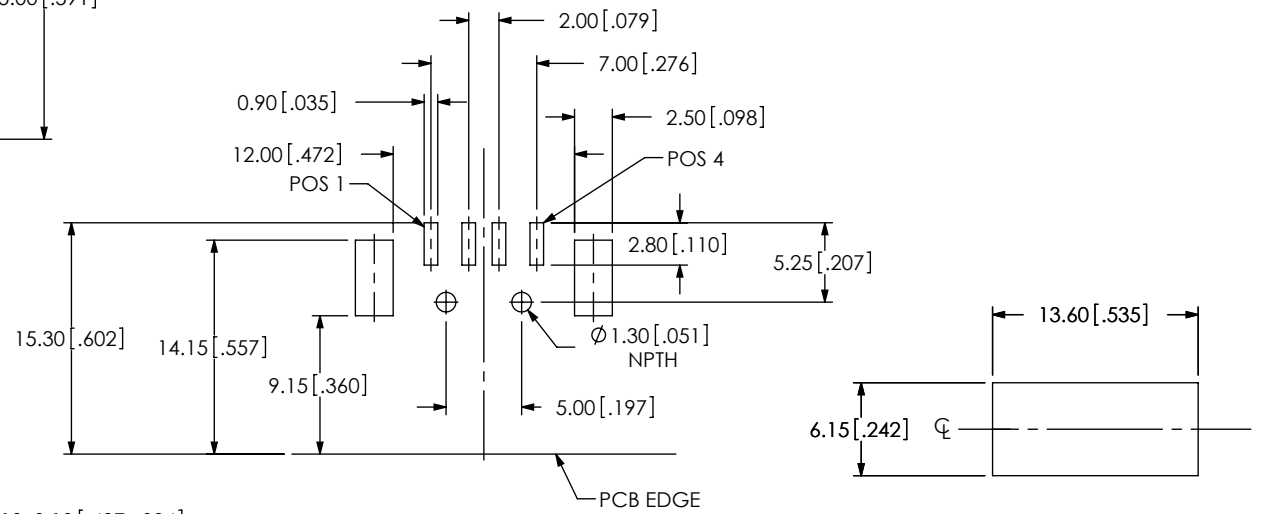

RECOMMENDED PCB LAYOUT

SUGGESTED PANEL CUTOUT DIMENSIONS

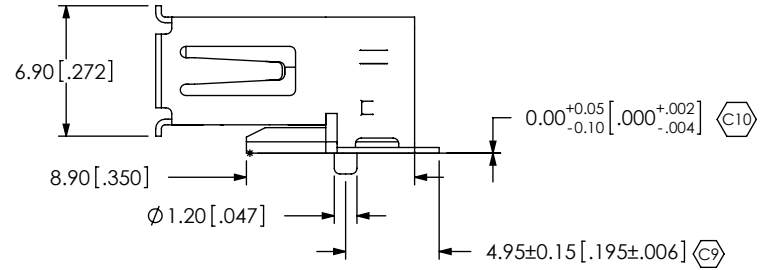

- NOTES:
1. C REPRESENTS CRITICAL DIMENSION.
 2. DELETED.
 3. DELETED.
 4. PARTS TO BE PACKAGED IN TRAYS.
 5. ALL PARTS ROHS COMPLIANT WITH OR WITHOUT -R.

UNLESS OTHERWISE SPECIFIED, DIMENSIONS ARE IN MILLIMETERS. TOLERANCES ARE:
DECIMALS ANGLES
X.X: ±0.3 [.01] 2°
X.XX: ±0.13 [.005]
X.XXX: ±0.051 [.0020]

PROPRIETARY NOTE
THIS DOCUMENT CONTAINS INFORMATION CONFIDENTIAL AND PROPRIETARY TO SAMTEC, INC. AND SHALL NOT BE REPRODUCED OR TRANSFERRED TO OTHER DOCUMENTS OR DISCLOSED TO OTHERS OR USED FOR ANY PURPOSE OTHER THAN THAT WHICH IT WAS OBTAINED WITHOUT THE EXPRESSED WRITTEN CONSENT OF SAMTEC, INC.

520 PARK EAST BLVD. NEW ALBANY, IN 47150
PHONE: 812-944-6733 FAX: 812-948-5047
e-Mail: info@SAMTEC.com code: 55322

MATERIAL: DO NOT SCALE DRAWING SHEET SCALE: 2:1	DESCRIPTION: USB A, SINGLE, SURFACE MOUNT 2
HOUSING: HI-TEMP NYLON UL 94V-0 CONTACT: COPPER ALLOY SHELL: COPPER ALLOY	DWG. NO. USB-A-S-X-X-SM2-X-XX
F:\DWG\MISC\MKTG\USB-A-S-X-X-SM2-X-XX-MKT.SLDDRW	BY: B.HARPEAU 2/24/2006 SHEET 1 OF 2

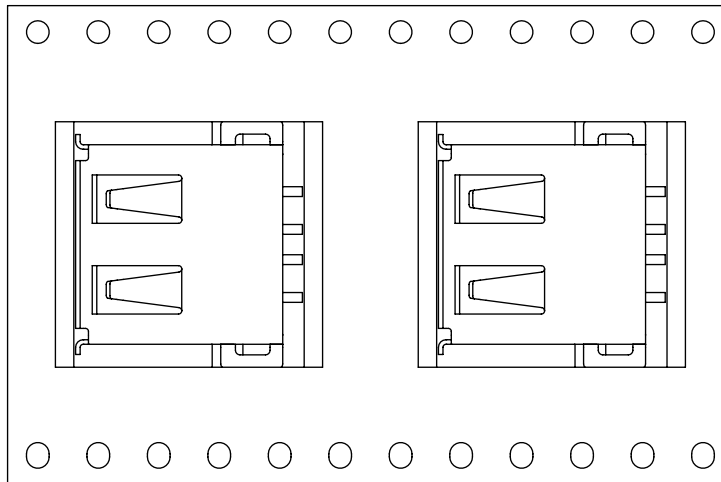

USER DIRECTION OF UN-REELING →
POCKET NOT DETAILED

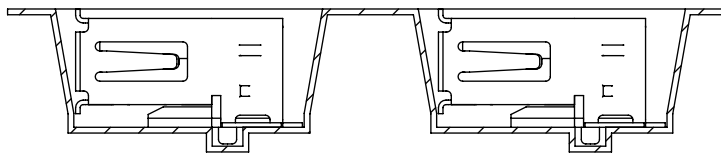

-TR: TAPE & REEL

PROPRIETARY NOTE
THIS DOCUMENT CONTAINS INFORMATION CONFIDENTIAL AND PROPRIETARY TO SAMTEC, INC. AND SHALL NOT BE REPRODUCED OR TRANSFERRED TO OTHER DOCUMENTS OR DISCLOSED TO OTHERS OR USED FOR ANY PURPOSE OTHER THAN THAT WHICH IT WAS OBTAINED WITHOUT THE EXPRESSED WRITTEN CONSENT OF SAMTEC, INC.

DO NOT SCALE DRAWING

SHEET SCALE: 1:1

samtec

520 PARK EAST BLVD, NEW ALBANY, IN 47150
PHONE: 812-944-6733 FAX: 812-948-5047
e-Mail: info@SAMTEC.com code: 55322

DESCRIPTION: USB A, SINGLE, SURFACE MOUNT 2

DWG. NO. USB-A-S-X-X-SM2-X-XX

BY: B.HARPENAU 2/24/2006 SHEET 2 OF 2