



SOT-223-5 Voltage Regulator Evaluation Board User's Guide

Note the following details of the code protection feature on Microchip devices:

- Microchip products meet the specification contained in their particular Microchip Data Sheet.
- Microchip believes that its family of products is one of the most secure families of its kind on the market today, when used in the intended manner and under normal conditions.
- There are dishonest and possibly illegal methods used to breach the code protection feature. All of these methods, to our knowledge, require using the Microchip products in a manner outside the operating specifications contained in Microchip's Data Sheets. Most likely, the person doing so is engaged in theft of intellectual property.
- Microchip is willing to work with the customer who is concerned about the integrity of their code.
- Neither Microchip nor any other semiconductor manufacturer can guarantee the security of their code. Code protection does not mean that we are guaranteeing the product as "unbreakable."

Code protection is constantly evolving. We at Microchip are committed to continuously improving the code protection features of our products. Attempts to break Microchip's code protection feature may be a violation of the Digital Millennium Copyright Act. If such acts allow unauthorized access to your software or other copyrighted work, you may have a right to sue for relief under that Act.

Information contained in this publication regarding device applications and the like is provided only for your convenience and may be superseded by updates. It is your responsibility to ensure that your application meets with your specifications. MICROCHIP MAKES NO REPRESENTATIONS OR WARRANTIES OF ANY KIND WHETHER EXPRESS OR IMPLIED, WRITTEN OR ORAL, STATUTORY OR OTHERWISE, RELATED TO THE INFORMATION, INCLUDING BUT NOT LIMITED TO ITS CONDITION, QUALITY, PERFORMANCE, MERCHANTABILITY OR FITNESS FOR PURPOSE. Microchip disclaims all liability arising from this information and its use. Use of Microchip devices in life support and/or safety applications is entirely at the buyer's risk, and the buyer agrees to defend, indemnify and hold harmless Microchip from any and all damages, claims, suits, or expenses resulting from such use. No licenses are conveyed, implicitly or otherwise, under any Microchip intellectual property rights.

Trademarks

The Microchip name and logo, the Microchip logo, Accuron, dsPIC, KEELOQ, KEELOQ logo, MPLAB, PIC, PICmicro, PICSTART, rPIC and SmartShunt are registered trademarks of Microchip Technology Incorporated in the U.S.A. and other countries.

FilterLab, Linear Active Thermistor, MXDEV, MXLAB, SEEVAL, SmartSensor and The Embedded Control Solutions Company are registered trademarks of Microchip Technology Incorporated in the U.S.A.

Analog-for-the-Digital Age, Application Maestro, CodeGuard, dsPICDEM, dsPICDEM.net, dsPICworks, dsSPEAK, ECAN, ECONOMONITOR, FanSense, In-Circuit Serial Programming, ICSP, ICEPIC, Mindi, MiWi, MPASM, MPLAB Certified logo, MPLIB, MPLINK, mTouch, PICkit, PICDEM, PICDEM.net, PICTail, PIC³² logo, PowerCal, PowerInfo, PowerMate, PowerTool, REAL ICE, rLAB, Select Mode, Total Endurance, UNI/O, WiperLock and ZENA are trademarks of Microchip Technology Incorporated in the U.S.A. and other countries.

SQTP is a service mark of Microchip Technology Incorporated in the U.S.A.

All other trademarks mentioned herein are property of their respective companies.

© 2008, Microchip Technology Incorporated, Printed in the U.S.A., All Rights Reserved.

 Printed on recycled paper.

QUALITY MANAGEMENT SYSTEM
CERTIFIED BY DNV
== ISO/TS 16949:2002 ==

Microchip received ISO/TS-16949:2002 certification for its worldwide headquarters, design and wafer fabrication facilities in Chandler and Tempe, Arizona; Gresham, Oregon and design centers in California and India. The Company's quality system processes and procedures are for its PIC[®] MCUs and dsPIC[®] DSCs, KEELOQ[®] code hopping devices, Serial EEPROMs, microperipherals, nonvolatile memory and analog products. In addition, Microchip's quality system for the design and manufacture of development systems is ISO 9001:2000 certified.



SOT-223-5 VOLTAGE REGULATOR EVALUATION BOARD USER'S GUIDE

Table of Contents

Preface	1
Introduction.....	1
Document Layout	1
Conventions Used in this Guide	2
Recommended Reading.....	3
The Microchip Web Site	3
Customer Support	3
Document Revision History	3
Chapter 1. Product Overview	
1.1 Introduction	5
1.2 What is the SOT-223-5 Voltage Regulator Evaluation Board?	5
1.3 What the SOT-223-5 Voltage Regulator Evaluation Board Kit Includes.	6
Chapter 2. Installation and Operation	
2.1 Introduction	7
2.2 Features	7
2.3 Getting Started	8
Appendix A. Schematic and Layouts	
A.1 Introduction	11
A.2 Board - Schematic	12
A.3 Board - Top Silkscreen	13
A.4 Board - Top Solder	14
A.5 Board - Bottom Solder	15
Appendix B. Bill Of Materials (BOM)	
Worldwide Sales and Service	18

SOT-223-5 Voltage Regulator Evaluation Board User's Guide

NOTES:



SOT-223-5 VOLTAGE REGULATOR EVALUATION BOARD USER'S GUIDE

Preface

NOTICE TO CUSTOMERS

All documentation becomes dated, and this manual is no exception. Microchip tools and documentation are constantly evolving to meet customer needs, so some actual dialogs and/or tool descriptions may differ from those in this document. Please refer to our web site (www.microchip.com) to obtain the latest documentation available.

Documents are identified with a "DS" number. This number is located on the bottom of each page, in front of the page number. The numbering convention for the DS number is "DSXXXXA", where "XXXX" is the document number and "A" is the revision level of the document.

For the most up-to-date information on development tools, see the MPLAB® IDE on-line help. Select the Help menu, and then Topics to open a list of available on-line help files.

INTRODUCTION

This chapter contains general information that will be useful to know before using the SOT-223-5 Voltage Regulator Evaluation Board. Items discussed in this chapter include:

- Document Layout
- Conventions Used in this Guide
- Recommended Reading
- The Microchip Web Site
- Customer Support
- Document Revision History

DOCUMENT LAYOUT

This document describes how to use the SOT-223-5 Voltage Regulator Evaluation Board. The manual layout is as follows:

- **Chapter 1. "Product Overview"** – Important information about the SOT-223-5 Voltage Regulator Evaluation Board.
- **Chapter 2. "Installation and Operation"** – This chapter includes a detailed description of each function of the demo board and instructions for how to begin using the board.
- **Appendix A. "Schematic and Layouts"** – Shows the schematic and layout diagrams for the SOT-223-5 Voltage Regulator Evaluation Board.
- **Appendix B. "Bill Of Materials (BOM)"** – Lists the parts used to build the SOT-223-5 Voltage Regulator Evaluation Board.

SOT-223-5 Voltage Regulator Evaluation Board User's Guide

CONVENTIONS USED IN THIS GUIDE

This manual uses the following documentation conventions:

DOCUMENTATION CONVENTIONS

Description	Represents	Examples
Arial font:		
Italic characters	Referenced books	<i>MPLAB[®] IDE User's Guide</i>
	Emphasized text	...is the <i>only</i> compiler...
Initial caps	A window	the Output window
	A dialog	the Settings dialog
	A menu selection	select Enable Programmer
Quotes	A field name in a window or dialog	"Save project before build"
Underlined, italic text with right angle bracket	A menu path	<u><i>File>Save</i></u>
Bold characters	A dialog button	Click OK
	A tab	Click the Power tab
N'Rnnnn	A number in verilog format, where N is the total number of digits, R is the radix and n is a digit.	4'b0010, 2'hF1
Text in angle brackets < >	A key on the keyboard	Press <Enter>, <F1>
Courier New font:		
Plain Courier New	Sample source code	#define START
	Filenames	autoexec.bat
	File paths	c:\mcc18\h
	Keywords	_asm, _endasm, static
	Command-line options	-Opa+, -Opa-
	Bit values	0, 1
	Constants	0xFF, 'A'
Italic Courier New	A variable argument	<i>file.o</i> , where <i>file</i> can be any valid filename
Square brackets []	Optional arguments	mcc18 [options] <i>file</i> [options]
Curly brackets and pipe character: { }	Choice of mutually exclusive arguments; an OR selection	errorlevel {0 1}
Ellipses...	Replaces repeated text	var_name [, var_name...]
	Represents code supplied by user	void main (void) { ... }

RECOMMENDED READING

This user's guide describes how to use SOT-223-5 Voltage Regulator Evaluation Board. Other useful documents are listed below. The following Microchip documents are available and recommended as supplemental reference resources.

MCP1790 Data Sheet, “70 mA, High Voltage Regulator“, DS22075

MCP1824 Data Sheet, “300 mA, Low Voltage, Low Quiescent Current LDO Regulator“, DS22070

MCP1825 Data Sheet, “500 mA, Low Voltage, Low Quiescent Current LDO Regulator“, DS22056

MCP1826 Data Sheet, “1000 mA, Low Voltage, Low Quiescent Current LDO Regulator“, DS22057

These datasheets provide useful information regarding voltage regulator parameters that may be validated using this evaluation board.

THE MICROCHIP WEB SITE

Microchip provides online support via our web site at www.microchip.com. This web site is used as a means to make files and information easily available to customers. Accessible by using your favorite Internet browser, the web site contains the following information:

- **Product Support** – Data sheets and errata, application notes and sample programs, design resources, user's guides and hardware support documents, latest software releases and archived software
- **General Technical Support** – Frequently Asked Questions (FAQs), technical support requests, online discussion groups, Microchip consultant program member listing
- **Business of Microchip** – Product selector and ordering guides, latest Microchip press releases, listing of seminars and events, listings of Microchip sales offices, distributors and factory representatives

CUSTOMER SUPPORT

Users of Microchip products can receive assistance through several channels:

- Distributor or Representative
- Local Sales Office
- Field Application Engineer (FAE)
- Technical Support
- Development Systems Information Line

Customers should contact their distributor, representative or field application engineer (FAE) for support. Local sales offices are also available to help customers. A listing of sales offices and locations is included in the back of this document.

Technical support is available through the web site at: <http://support.microchip.com>

DOCUMENT REVISION HISTORY

Revision A (July 2008)

- Initial Release of this Document.

SOT-223-5 Voltage Regulator Evaluation Board User's Guide

NOTES:



SOT-223-5 VOLTAGE REGULATOR EVALUATION BOARD USER'S GUIDE

Chapter 1. Product Overview

1.1 INTRODUCTION

The SOT-223-5 Voltage Regulator Evaluation Board is designed to provide functional evaluation of Microchip Voltage Regulators that utilize the SOT223-5 package and the following device pinout:

Pin 1 = $\overline{\text{SHDN}}$

Pin 2 = V_{IN}

Pin 3 = GND

Pin 4 = V_{OUT}

Pin 5 = PWRGD / ADJ

The SOT-223-5 Voltage Regulator Evaluation Board does not come with a voltage regulator soldered onto the board. This allows the users to attach the voltage regulator of their choosing to the board and perform quiescent current, ground current, PSRR, and other desired tests.

The SOT-223-5 Voltage Regulator Evaluation Board is based upon a modular concept that will allow the user to plug in additional boards to increase the test capability of the voltage regulator. Planned additional modular plugin boards currently consist of an Input Voltage Linestep Board, Output Voltage Loadstep Board, and several other device packages.

1.2 WHAT IS THE SOT-223-5 VOLTAGE REGULATOR EVALUATION BOARD?

The SOT-223-5 Voltage Regulator Evaluation Board is designed to evaluate and test voltage regulators. By soldering the desired device to the evaluation board, the user can easily validate several parameters of the device.

1.2.1 Functional Blocks

The SOT-223-5 Voltage Regulator Evaluation Board can be broken up into 6 functional blocks. The blocks are:

- Input Capacitance
- Shutdown Control
- Ground Current Measurement
- Voltage Adjust
- Power Good
- Load Resistor

1.2.2 Input Capacitance

Jumper JP1 connects the input capacitance to the circuit. The input capacitor is disconnected when performing Power Supply Ripple Rejection tests. By default, C_1 is populated with a 1 μF , 50V, XR7 ceramic capacitor.

1.2.3 Shutdown Control

Jumper JP2 allows the user to select the Shutdown ($\overline{\text{SHDN}}$) pin voltage level. The voltage level may be set to V_{IN} , GND, or open, depending on the placement of the JP2 jumper. When the jumper is not connecting pins 1 and 2, or pins 2 and 3 of JP2, the voltage level may be set by attaching a signal to TP5. This allows the user to enable, disable, or pulse the shutdown pin of the device.

The board comes with R_1 populated with a 10 k Ω resistor.

1.2.4 Ground Current Measurement

Jumper JP3 allows measurement of ground current. When a current meter is connected to TP6 and TP7 and jumper JP3 is removed, the ground current of the device may be measured.

1.2.5 Voltage Adjust

For Adjustable Output Voltage devices, R_2 and R_3 may be populated with appropriate values to provide the desired output voltage.

The board comes with R_2 populated with a 68.5 k Ω resistor.

1.2.6 Power-Good (PWRGD)

For devices with a Power-Good (PWRGD) output, either R_2 or R_4 is populated, depending on the desired pullup source voltage.

- R_2 selects V_{OUT} as the pull-up source voltage.
- R_4 selects V_{IN} as the pull-up source voltage.

The board comes with R_2 populated with a 68.5 k Ω resistor.

1.2.7 Load Resistor

R_5 and R_6 may be populated with the desired load resistor values for the device being evaluated. JP4 connects R_5 to the device output, JP5 connects R_6 to the device output.

1.2.8 Output Capacitor

C_2 may be populated with the desired output capacitance. By default, C_2 is populated with a 1 μF , 6.3V, XR7 ceramic capacitor.

1.2.9 Power Supply

J1 or TP1 and TP2 are connected to the user's power supply.

1.3 WHAT THE SOT-223-5 VOLTAGE REGULATOR EVALUATION BOARD KIT INCLUDES.

This SOT-223-5 Voltage Regulator Evaluation Board kit includes:

- SOT-223-5 Voltage Regulator Evaluation Board, 102-00198
- Microchip Analog and Interface Products Demonstration Boards CD-ROM (DS21912)
 - SOT-223-5 Voltage Regulator Evaluation Board User's Guide, (DS51751)



SOT-223-5 VOLTAGE REGULATOR EVALUATION BOARD USER'S GUIDE

Chapter 2. Installation and Operation

2.1 INTRODUCTION

The SOT-223-5 Voltage Regulator Evaluation Board is designed to be used to facilitate the evaluation of Microchip's voltage regulators or to be used as a standalone voltage regulator board. Jumpers have been placed on the board to facilitate testing of specific voltage regulator parameters. The jumpers may also be used to select pull-up and pull-down voltage levels.

The SOT-223-5 Voltage Regulator Evaluation Board kit comes with a 1 μ F ceramic input and output capacitor soldered to the board. A 10 $k\Omega$ resistor in series with the SHDN pin is also populated on the board. The PWRGD/ADJ pin has a 69.8 $k\Omega$ resistor soldered to the board. The board has four more unpopulated resistor locations that may be used for loads and voltage adjustments.

2.2 FEATURES

The SOT-223-5 Voltage Regulator Evaluation Board has the following features:

- Input and Output headers for future connection to Line Step and Load Step modules
- Ample testpoints to attach multimeters, power supplies, and loads
- Jumper to select ground current measurement
- Jumper to select input capacitor
- Jumper to select two different load resistors
- Jumper to select shutdown pin input: V_{DD} , GND, or use test point
- Jumper to connect input capacitor to circuit
- SMT0805 PCB footprints for user Power-Good pull-up resistor
- SMT0805 PCB footprints for user Adjustable Voltage resistor divider
- SMT0805 PCB footprints for user Bypass Capacitor

SOT-223-5 Voltage Regulator Evaluation Board User's Guide

2.3 GETTING STARTED

The SOT-223-5 Voltage Regulator Evaluation Board is fully assembled and tested. All that is required for operating is a user supplied voltage regulator and a supply voltage source. Some of the tests that may be completed using the SOT-223-5 Voltage Regulator Evaluation Board shall now be described.

2.3.1 Ground Current and Quiescent Current

When measuring ground current, jumper JP3 should be removed, otherwise leave jumper JP3 on. To measure ground current, perform the following steps.

1. Add desired load resistors to R₅ and R₆.
2. Remove jumpers JP3, JP4, and JP5.
3. Connect an Ampere Meter across test points TP6(+) and TP7(-). Select the appropriate meter scale for the device being evaluated.
4. Connect a voltmeter across testpoints TP9(+) and TP10(-).
5. Add jumper JP1.
6. Add jumper JP2 to pins 1 and 2.
7. Apply source voltage to test points TP1(+) and TP2(-).
8. Verify the voltage across test points TP6 and TP7 is within the expected range of the device being tested.
9. Read the Ground Current directly from the ampere meter connected to test points TP6 and TP7.
10. Vary the input voltage to obtain data for ground current versus input voltage. With no load attached to the output of the voltage regulator, the measured **ground current** is also called the **quiescent current** of the regulator.
11. Add a load selection jumper, JP4 or JP5.
12. Read the Ground Current directly from the ampere meter connected to test points TP6 and TP7.
13. The data collected will be the **ground current** versus load current.

2.3.2 Adjustable Output Voltage

The output voltage of some adjustable voltage regulators may be adjusted by selecting appropriate resistor divider values connected to the Adjust (ADJ) pin. R₂ and R₃ pads are available to be used as voltage divider.

2.3.3 Shutdown Input Selection

The Shutdown ($\overline{\text{SHDN}}$) input selection may be set to V_{IN} , GND, or a user supplied voltage using test point TP5. To select V_{IN} as the $\overline{\text{SHDN}}$ voltage, place a jumper across pins JP2-1 and JP2-2. To select GND as the $\overline{\text{SHDN}}$ voltage, place a jumper across pins JP2 and JP3. To select a user specified input such as a function generator, remove the jumper from JP2 and connect the external voltage source positive lead (+) to test point TP5 and the negative lead (-) to test point TP4.

2.3.4 Power-Good (PWRGD)

The Power-Good (PWRGD) output pin has the ability to be pulled up to either V_{IN} or V_{OUT} . Populating R_2 (and removing R_4) with the desired pull-up resistor causes PWRGD to be pulled up to V_{OUT} . Populating R_4 (and removing R_2) with the desired pull-up resistor causes PWRGD to be pulled up to V_{IN} .

When PWRGD is pulled up to V_{OUT} , the device current will be minimal when \overline{SHDN} is active. When PWRGD is pulled up to V_{IN} , the device current will be higher when \overline{SHDN} is active, because the current will flow through R_4 and the PWRGD pin to ground. When low operating currents are critical, PWRGD should be pulled up to V_{OUT} . That will keep current consumption at a minimum when \overline{SHDN} is active because the output voltage will be low.

2.3.5 Load Resistance

R_5 and R_6 are used to set desired load values. One choice is to set R_5 to the minimum current desired for testing. R_6 would then be set to a value desired for specific tests. Either value may be selected by adding the respective jumpers.

2.3.6 Line Step

Dynamic Line Step response may be evaluated by connecting an electronically switched input voltage to test points TP1(+) and TP2(-) or to connector J1. An oscilloscope is connected to TP3(Ch1 Trigger), TP9(Ch2) and TP10(GND). An appropriate load is selected using R_5 and JP4 or R_6 and JP5. The input voltage is then electronically switched from a low voltage to a high voltage. The corresponding voltage waveform data of the voltage regulator response is captured by the oscilloscope. Microchip will be offering a Line Step module that connects directly to connector J1. The Line Step module will be capable of switching between two voltage levels that the user supplies.

2.3.7 Load Step

The Dynamic Load Step response may be evaluated by connecting an electronically switched load to test points TP9(+) and TP10(-) or to connector P1. An oscilloscope is connected to the electronic load switch signal (Ch1 Trigger) and to TP9(Ch2) and TP10(Gnd). The load is then electronically switched from a high resistance to a low resistance. The corresponding voltage waveform data of the voltage regulator response is captured by the oscilloscope. Microchip will be offering a Load Step module that connects directly to connector P1. The Load Step module will have several selectable load values populated onboard to cover a wide range of loads. The load will have the ability to be electronically or manually switched.

2.3.8 Power Supply Rejection Ratio (PSRR)

Power Supply Rejection Ratio tests are performed by removing the input capacitor jumper, JP1, and connecting an appropriate PSRR analyzer to the SOT-223-5 Voltage Regulator Evaluation Board. The PSRR analyzer may then sweep the input voltage frequencies and record the corresponding output voltages.

SOT-223-5 Voltage Regulator Evaluation Board User's Guide

NOTES:



SOT-223-5 VOLTAGE REGULATOR EVALUATION BOARD USER'S GUIDE

Appendix A. Schematic and Layouts

A.1 INTRODUCTION

This appendix contains the following schematics and layouts for the SOT-223-5 Voltage Regulator Evaluation Board:

- Board - Schematic
- Board - Top Silk
- Board - Top Solder
- Board - Bottom Solder

SOT-223-5 Voltage Regulator Evaluation Board User's Guide

A.2 BOARD - SCHEMATIC

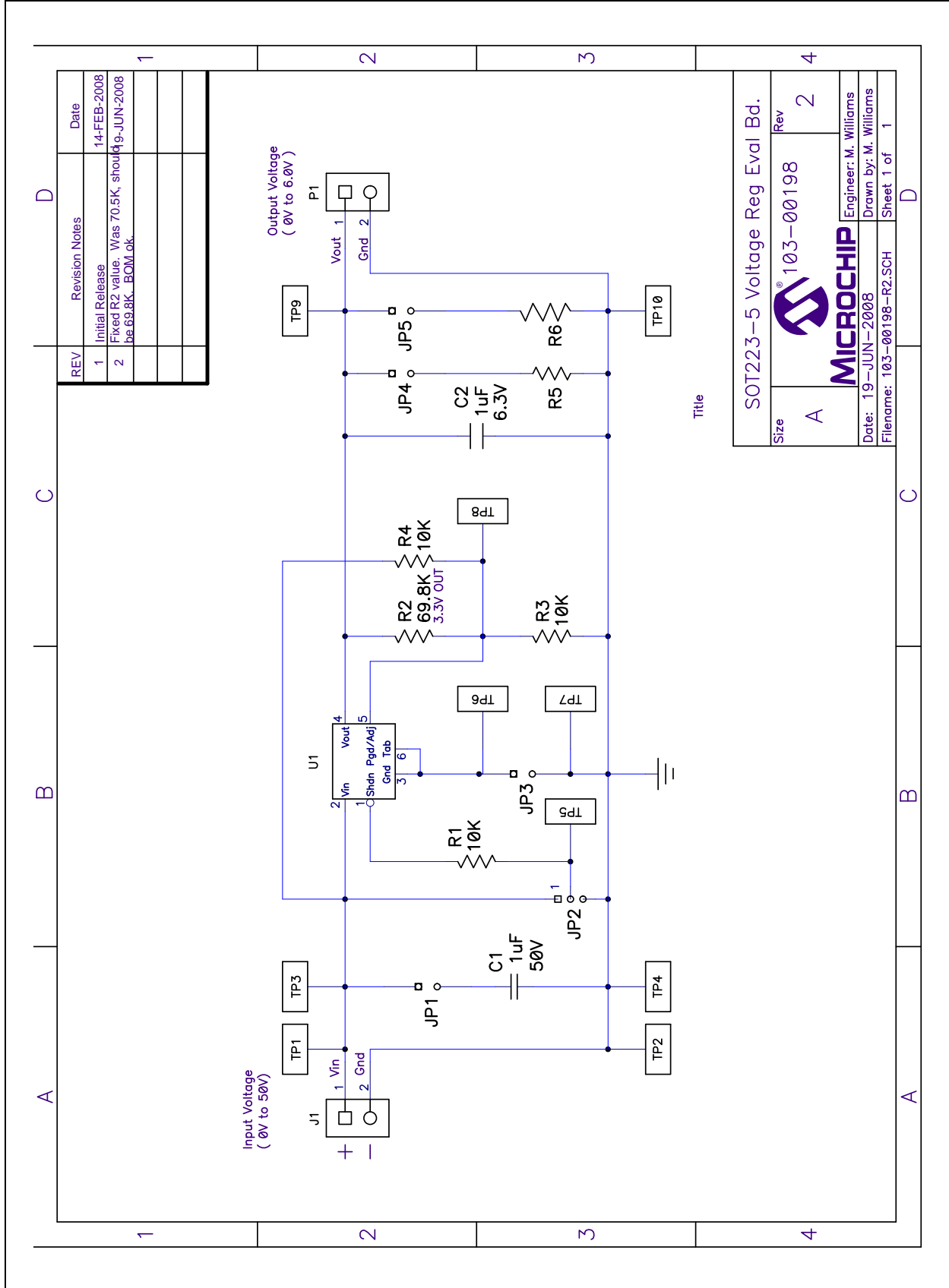

A.3 BOARD - TOP SILKSCREEN

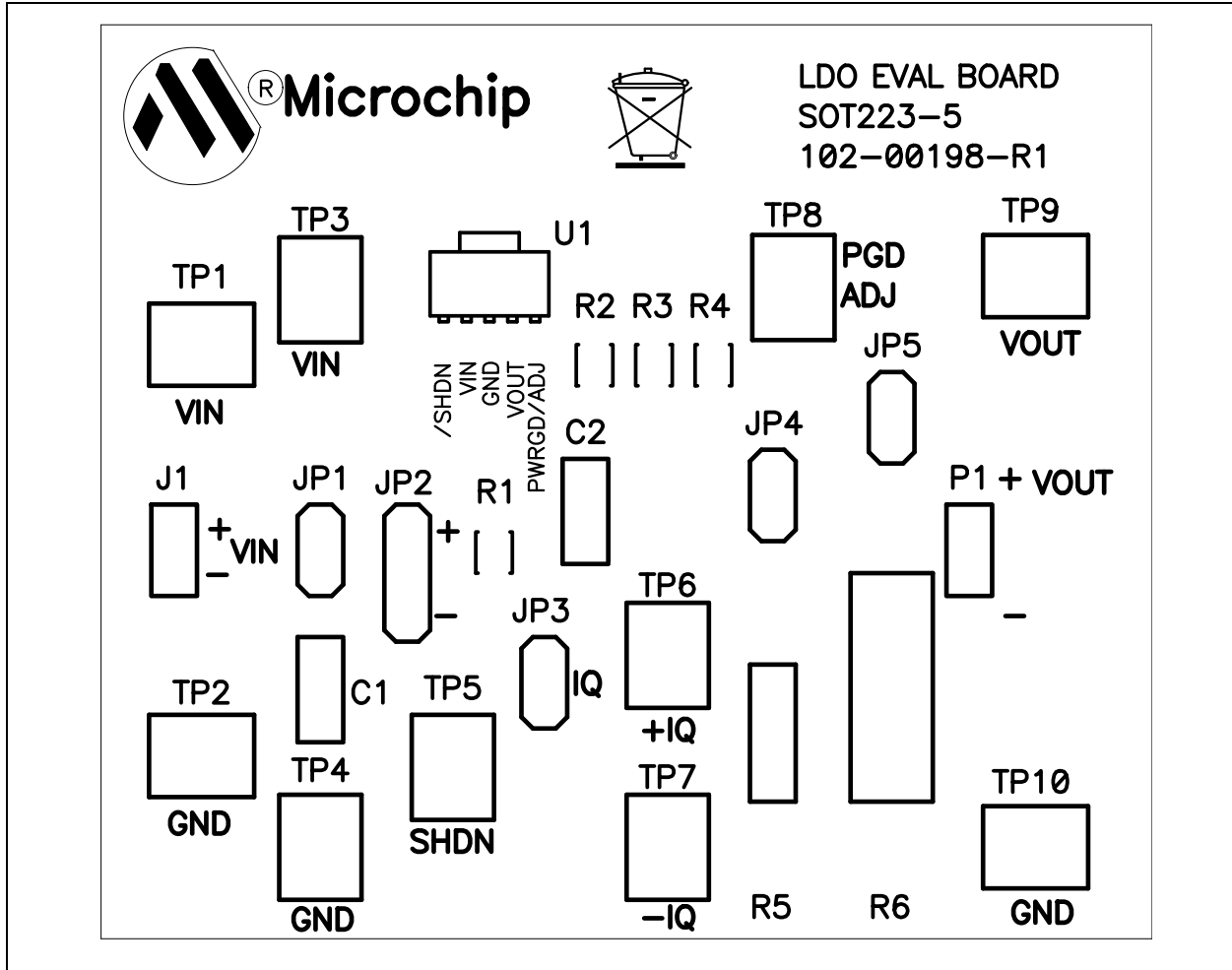

A.4 BOARD - TOP SOLDER

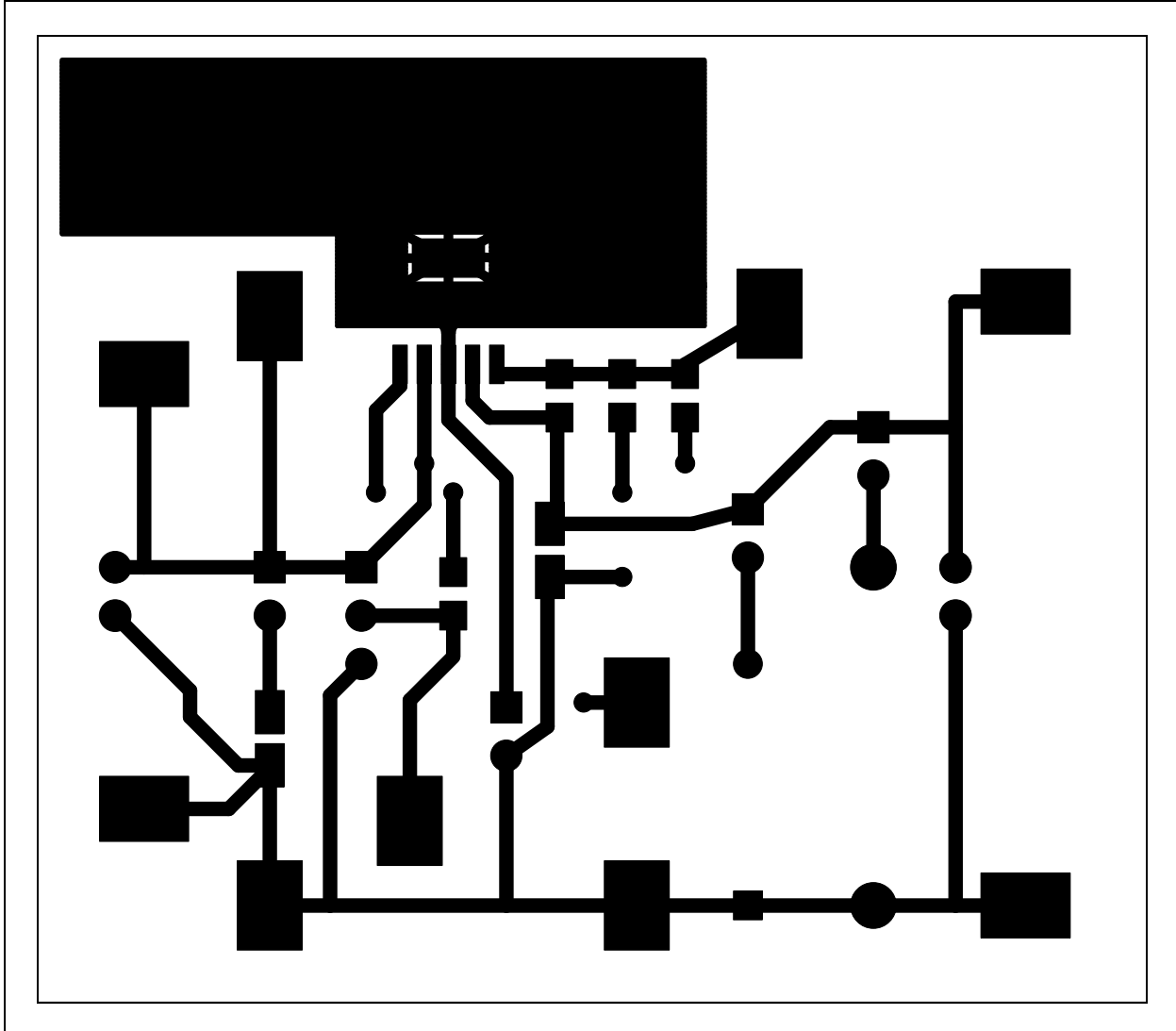

A.5 BOARD - BOTTOM SOLDER



SOT-223-5 Voltage Regulator Evaluation Board User's Guide

NOTES:



SOT-223-5 VOLTAGE REGULATOR EVALUATION BOARD USER'S GUIDE

Appendix B. Bill Of Materials (BOM)

TABLE B-1: BILL OF MATERIALS (BOM)

Qty	Reference	Description	Manufacturer	Part Number
1	C1	Capacitor, Ceramic, 1 uF, 50V, X7R, SMT 0805	Murata	GRM21BR71H105KA12L
1	C2	Capacitor, Ceramic, 1 uF, 16V, X7R, SMT 0805	Kemet [®] Electronics Corp	C0805C105K4RACTU
1	J1	2 pin RA header, 0.100 centers, 0.025 sq pins, 0.070 pcb to pin center height, 36 pins to a strip (yields 18 headers)	3M	929835-01-36-RK
4	JP1, JP3, JP4, JP5	2 pin header, 0.100 centers, 0.025 sq pins, 0.070 pcb to pin center height, 36 pins to a strip (yields 18 headers)	Molex [®] Electronics	22-28-4360
1	JP2	3 pin header, 0.100 centers, 0.025 sq pins, 0.070 pcb to pin center height, 36 pins to a strip (yields 12 headers)	Molex Electronics	22-28-4360
1	P1	RA socket, 0.100 centers, 0.025 sq pins, 0.070 pcb to pin center height	Sullins Electronics Inc.	PPPC021LGBN-RC
1	R1	10K Resistor, 1%, 1/8W, SMT 0805	Rohm CO., LTD	MCR10EZHF1002
1	PCB	Printed Circuit Board	Microchip Technology Inc.	104-00198
1	R2	69.8K Resistor, 1%, 1/8W, SMT 0805	Rohm CO., LTD	MCR10EZHF6982
10	TP1-TP10	SMT Testpoint	Keystone Electronics [®]	5016

Note: The components listed in this Bill of Materials are representative of the PCB assembly. The released BOM used in manufacturing uses all RoHS-compliant components.



WORLDWIDE SALES AND SERVICE

AMERICAS

Corporate Office

2355 West Chandler Blvd.
Chandler, AZ 85224-6199
Tel: 480-792-7200
Fax: 480-792-7277
Technical Support:
<http://support.microchip.com>
Web Address:
www.microchip.com

Atlanta

Duluth, GA
Tel: 678-957-9614
Fax: 678-957-1455

Boston

Westborough, MA
Tel: 774-760-0087
Fax: 774-760-0088

Chicago

Itasca, IL
Tel: 630-285-0071
Fax: 630-285-0075

Dallas

Addison, TX
Tel: 972-818-7423
Fax: 972-818-2924

Detroit

Farmington Hills, MI
Tel: 248-538-2250
Fax: 248-538-2260

Kokomo

Kokomo, IN
Tel: 765-864-8360
Fax: 765-864-8387

Los Angeles

Mission Viejo, CA
Tel: 949-462-9523
Fax: 949-462-9608

Santa Clara

Santa Clara, CA
Tel: 408-961-6444
Fax: 408-961-6445

Toronto

Mississauga, Ontario,
Canada
Tel: 905-673-0699
Fax: 905-673-6509

ASIA/PACIFIC

Asia Pacific Office

Suites 3707-14, 37th Floor
Tower 6, The Gateway
Harbour City, Kowloon
Hong Kong
Tel: 852-2401-1200
Fax: 852-2401-3431

Australia - Sydney

Tel: 61-2-9868-6733
Fax: 61-2-9868-6755

China - Beijing

Tel: 86-10-8528-2100
Fax: 86-10-8528-2104

China - Chengdu

Tel: 86-28-8665-5511
Fax: 86-28-8665-7889

China - Hong Kong SAR

Tel: 852-2401-1200
Fax: 852-2401-3431

China - Nanjing

Tel: 86-25-8473-2460
Fax: 86-25-8473-2470

China - Qingdao

Tel: 86-532-8502-7355
Fax: 86-532-8502-7205

China - Shanghai

Tel: 86-21-5407-5533
Fax: 86-21-5407-5066

China - Shenyang

Tel: 86-24-2334-2829
Fax: 86-24-2334-2393

China - Shenzhen

Tel: 86-755-8203-2660
Fax: 86-755-8203-1760

China - Wuhan

Tel: 86-27-5980-5300
Fax: 86-27-5980-5118

China - Xiamen

Tel: 86-592-2388138
Fax: 86-592-2388130

China - Xian

Tel: 86-29-8833-7252
Fax: 86-29-8833-7256

China - Zhuhai

Tel: 86-756-3210040
Fax: 86-756-3210049

ASIA/PACIFIC

India - Bangalore

Tel: 91-80-4182-8400
Fax: 91-80-4182-8422

India - New Delhi

Tel: 91-11-4160-8631
Fax: 91-11-4160-8632

India - Pune

Tel: 91-20-2566-1512
Fax: 91-20-2566-1513

Japan - Yokohama

Tel: 81-45-471- 6166
Fax: 81-45-471-6122

Korea - Daegu

Tel: 82-53-744-4301
Fax: 82-53-744-4302

Korea - Seoul

Tel: 82-2-554-7200
Fax: 82-2-558-5932 or
82-2-558-5934

Malaysia - Kuala Lumpur

Tel: 60-3-6201-9857
Fax: 60-3-6201-9859

Malaysia - Penang

Tel: 60-4-227-8870
Fax: 60-4-227-4068

Philippines - Manila

Tel: 63-2-634-9065
Fax: 63-2-634-9069

Singapore

Tel: 65-6334-8870
Fax: 65-6334-8850

Taiwan - Hsin Chu

Tel: 886-3-572-9526
Fax: 886-3-572-6459

Taiwan - Kaohsiung

Tel: 886-7-536-4818
Fax: 886-7-536-4803

Taiwan - Taipei

Tel: 886-2-2500-6610
Fax: 886-2-2508-0102

Thailand - Bangkok

Tel: 66-2-694-1351
Fax: 66-2-694-1350

EUROPE

Austria - Wels

Tel: 43-7242-2244-39
Fax: 43-7242-2244-393

Denmark - Copenhagen

Tel: 45-4450-2828
Fax: 45-4485-2829

France - Paris

Tel: 33-1-69-53-63-20
Fax: 33-1-69-30-90-79

Germany - Munich

Tel: 49-89-627-144-0
Fax: 49-89-627-144-44

Italy - Milan

Tel: 39-0331-742611
Fax: 39-0331-466781

Netherlands - Drunen

Tel: 31-416-690399
Fax: 31-416-690340

Spain - Madrid

Tel: 34-91-708-08-90
Fax: 34-91-708-08-91

UK - Wokingham

Tel: 44-118-921-5869
Fax: 44-118-921-5820