

## BRUSHLESS DC MOTOR FAMILY

### Series NT DYNAMO<sup>®</sup> Brushless DC Permanent Magnet Motor



The NT DYNAMO<sup>®</sup> is designed to provide:

- Maximum application flexibility
- Increased reliability
- Affordable Servo Control
- Smooth motion quality
- Matched motor and drive performance
- Plug-n-Play

Perfect for applications in office automation, instrumentation and medical equipment:

- High speed copiers and printers
- ATM machines
- Medical analyzers
- Mail processing and sorter
- General purpose equipment

#### NT DYNAMO<sup>®</sup> BLDC Motor Specifications

- Standardized Modules
  - Brings high volume pricing to low volume orders
  - Makes product performance easy to specify
  - Ensures maximum product quality
- Flexible Performance
  - Operates from 12-48Vdc power sources
  - Operates in speed or torque mode
  - 4 quadrant closed loop or 2 quadrant open loop
  - Compact integrated encoder option

### Electrical

- Integral Motor Controls Matched to a Motor Winding
- 2 or 4 Quadrant Operation
- 10Vdc-48Vdc Range (depending on motor control)
- Up to 50 oz-in [282 mN-m] Torque (with no gearing)
- Ultra Smooth Precision Motion Quality
-  Approved Class B Insulation System
- 100% Final Tested
- Custom Windings Available

### Mechanical

- Long Life Ball Bearing System
- Size 17 and NEMA 23 Mounting Flange
- Neodymium Ring Magnets (not arcs)
- Stainless Steel Shaft
- Over 20,000 Hours of Design Life @ Rated Torque
- Standard Molex<sup>®</sup> Connectors
- Small Package Size with Low Rotor Inertia
- Up to 6000 RPM Operation

### Reliability

- Over 1.5 Million Hours of Combined Life and Reliability Testing
- In Use at Major OEM's in Demanding Applications
- Our Proven Design can Help Reduce the Test Time Needed to Validate Your Design
- Contact Hurst for Detailed Life and Reliability Data

### Integral Motor Control and Encoders

- External Motor Module
  - For Use with Customer Supplied Motor Control
  - Provides Hall Sensor and/or Encoder Outputs
- Analog Motor Control
  - Economical Control via a Simple Speed Pot or a 0-5Vdc Control Signal
- PWM Motor Control
  - Control via Customer Generated PWM Signal
- Encoders – 100, 250, 256 with Index Pulse, 400, or 1000 Line Resolution

## INTEGRATED CONTROL DRAWINGS

### SIZE 17 MOUNTING

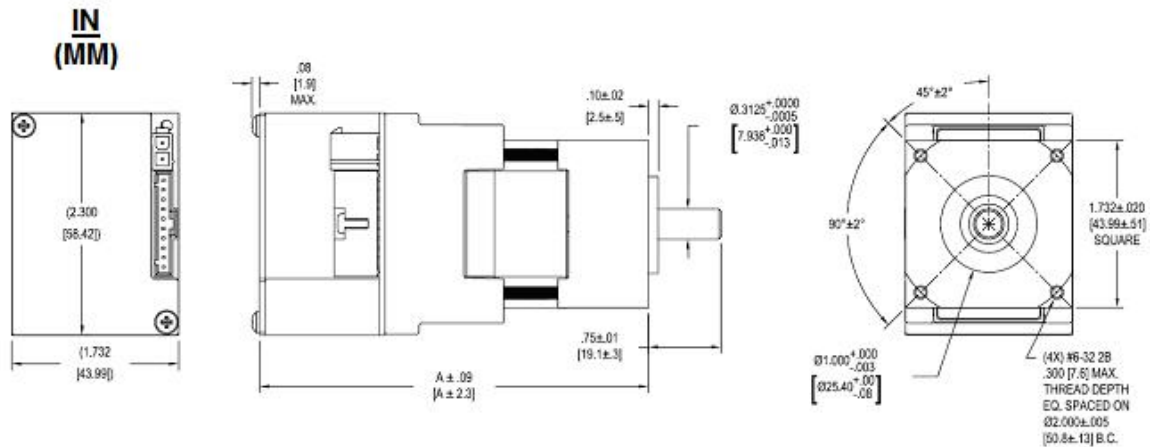

Model	Overall Length (A)
1	3.79 [96.3]
2	4.04 [102.6]

Model	Overall Length (A)
3	4.79 [121.7]
4,5,6	6.29 [159.7]

### NEMA 23 MOUNTING

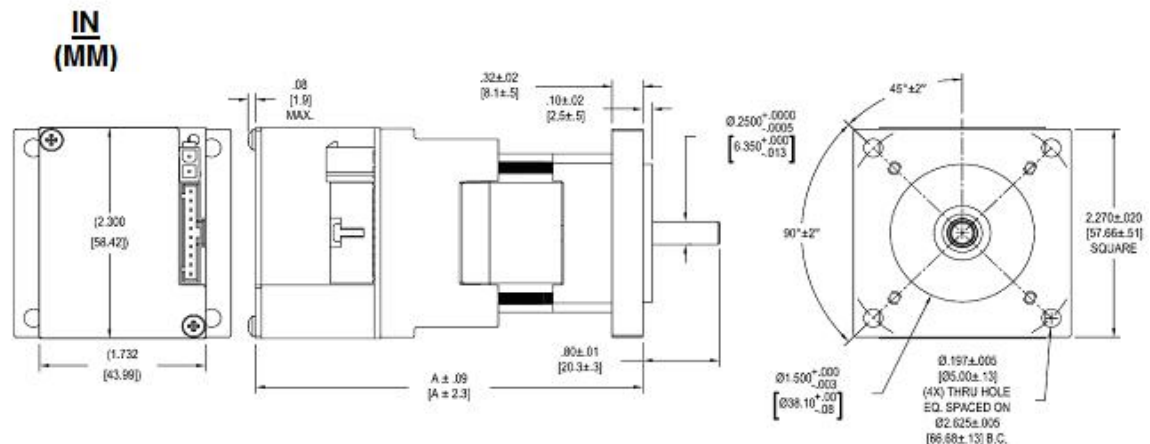

Model	Overall Length (A)
1	3.79 [96.3]
2	4.04 [102.6]

Model	Overall Length (A)
3	4.79 [121.7]
4,5,6	6.29 [159.7]

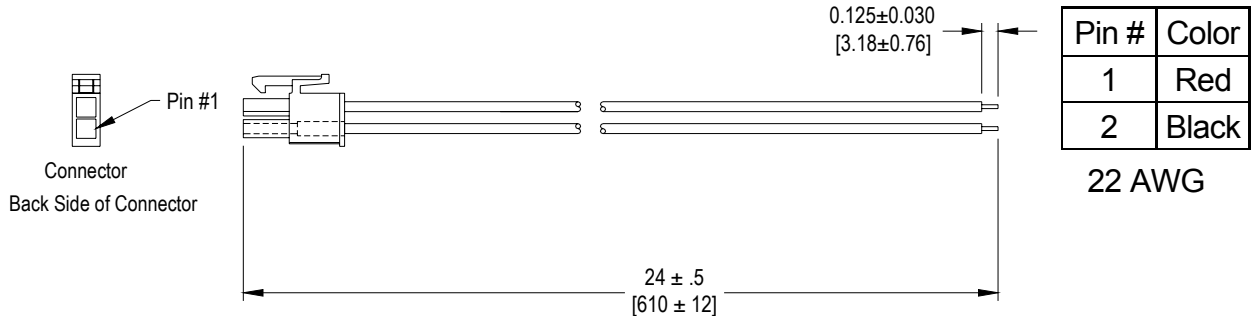

Description	Manufacturer	Manufacturer Part #
Connector	Molex	39-01-2020
Terminal	Molex	39-00-0038 (chain)
	Molex	39-00-0039 (loose)

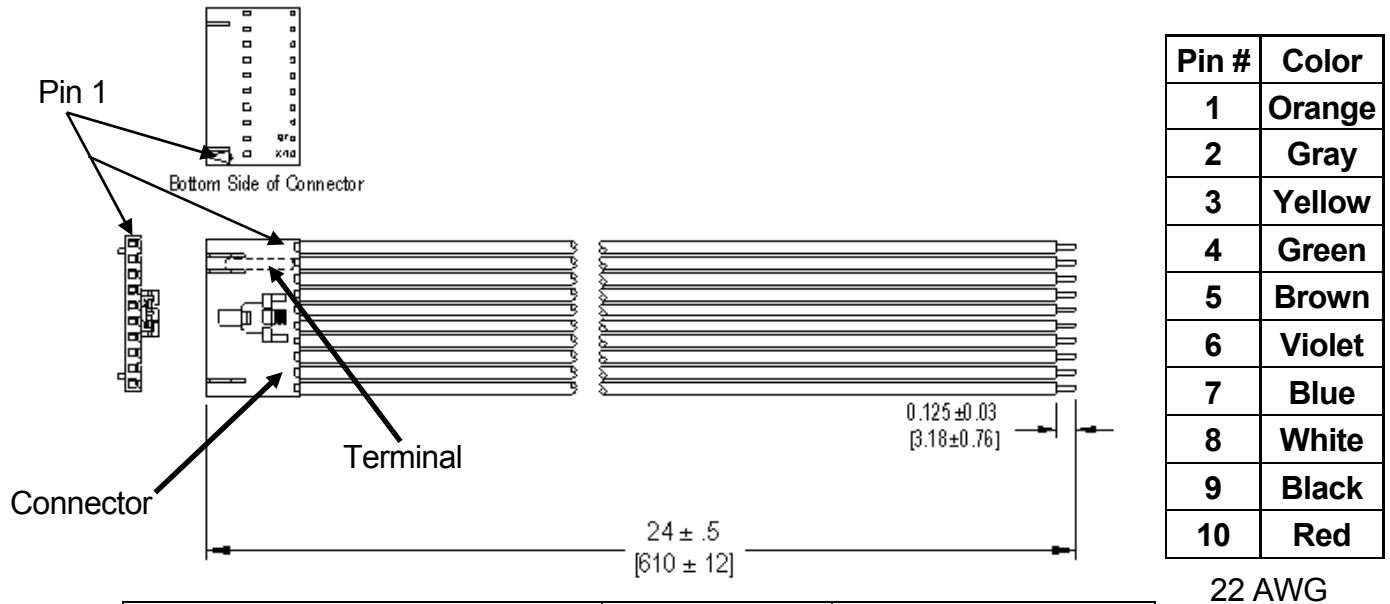

Description	Manufacturer	Manufacturer Part #
Connector	Molex	50-57-9410
Terminal	Molex	16-02-0087 (chain)
	Molex	16-02-0103 (loose)

## NOTICE

Minimum Gauge Size is recommended to be 22 AWG or greater.

## EXTERNAL CONTROL DRAWINGS

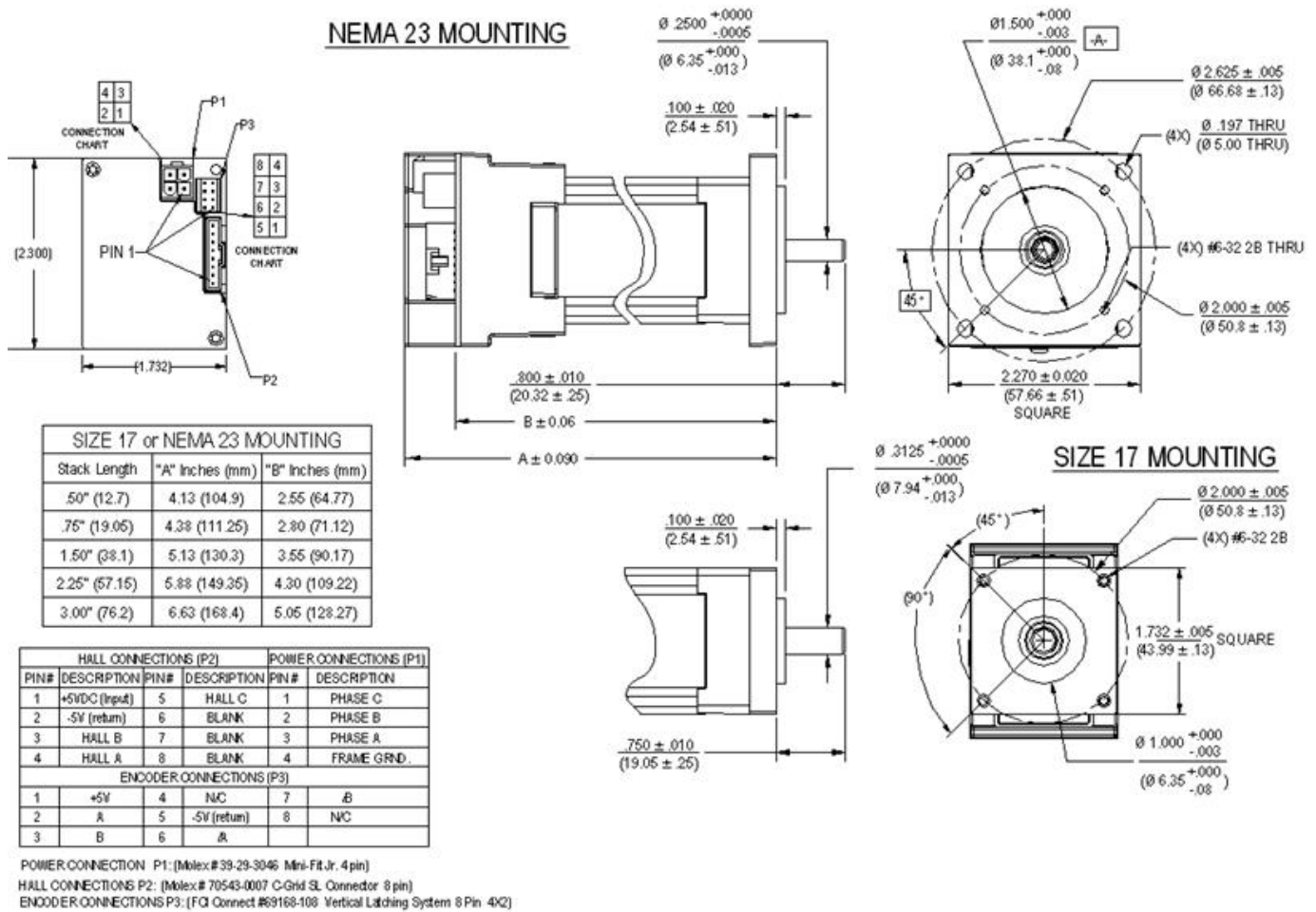

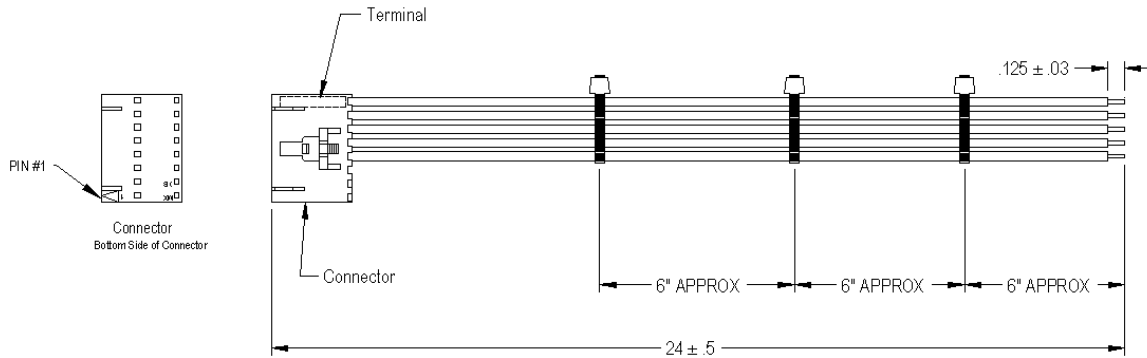

Pin #	Color
1	Red
2	Black
3	Brown
4	White
5	Green

Description	Manufacturer	Manufacturer Part #
Connector	Molex	50-57-9408
Terminal		16-02-0087 (chain) 16-02-0103 (loose)
22 AWG Wire, Red	Belden	32822 0025000
22 AWG Wire, Black	Belden	32822 0105000
22 AWG Wire, Brown	Belden	32822 0015000
22 AWG Wire, White	Belden	32822 0095000
22 AWG Wire, Green	Belden	32822 0055000
Cable Tie		

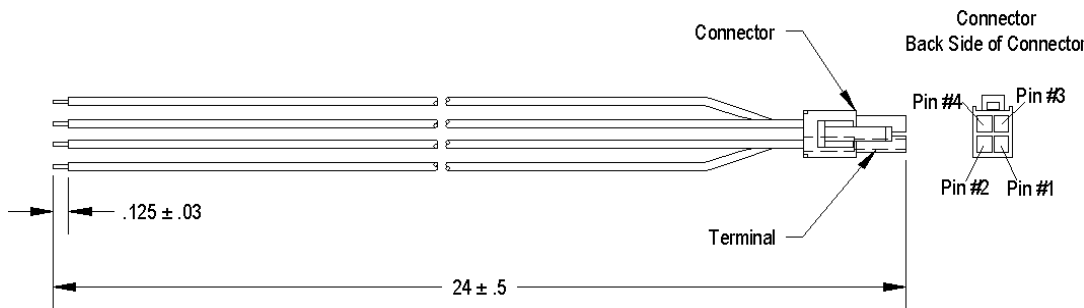

Pin #	Color
1	Red
2	Black
3	White
4	Green

Description	Manufacturer	Manufacturer P/N
Connector	Molex	39-01-2040
Terminal	Molex	39-00-0038 (chain) 39-00-0039 (loose)
22 AWG Wire, Red	Belden	32822 0025000
22 AWG Wire, Black	Belden	32822 0105000
22 AWG Wire, White	Belden	32822 0095000
22 AWG Wire, Green	Belden	32822 0055000

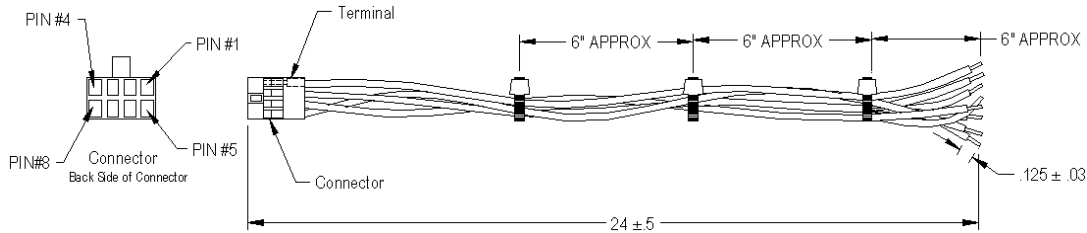

Pin #	Color
1	Red
2	White
3	Blue
4	Gray
5	Black
6	Orange
7	Brown
8	Green

Description	Manufacturer	Manufacturer Part #
Connector	FCI	65846-016
Terminal	FCI	48051-000 (chain)
		48236-000 (loose)
22 AWG Wire, Red	Belden	32822 0025000
22 AWG Wire, White	Belden	32822 0095000
22 AWG Wire, Blue	Belden	32822 0135000
22 AWG Wire, Gray	Belden	32822 0085000
22 AWG Wire, Black	Belden	32822 0105000
22 AWG Wire, Orange	Belden	32822 0035000
22 AWG Wire, Brown	Belden	32822 0015000
22 AWG Wire, Green	Belden	32822 0055000
Cable Tie		

## NOTICE

Minimum Gauge Size is recommended to be 22 AWG or greater.