

# AS5132

## 360 Step (8.5 bit) Programmable High Speed Magnetic Position Sensor

### General Description

The AS5132 is a contactless magnetic position sensor for accurate angular measurement over a full turn of 360 degrees. It is a system-on-chip, combining integrated Hall elements, analog frontend and digital signal processing in a single device. To measure the angle, only a simple two-pole magnet, rotating over the center of the chip is required.

The absolute angle measurement provides instant indication of the magnet's angular position with a resolution of 8.5 bit = 360 positions per revolution. This digital data is available as serial output over the interface and as a pulse width modulated (PWM) signal.

An additional U,V,W output can be used for a block commutation for a brushless DC motor. An incremental signal is available as an option.

In addition to the angle information, the strength of the magnetic field is also available as a 5-bit code.

A one time programmable (OTP) memory is used for permanent zero angle position programming. The magnet does not need to be aligned mechanically.

*Ordering Information and Content Guide appear at end of datasheet.*

### Key Benefits & Features

The benefits and features of AS5132, 360 Step (8.5 bit) Programmable High Speed Magnetic Position Sensor are listed below:

**Figure 1:**  
Added Value of Using AS5132

Benefits	Features
<ul style="list-style-type: none"> <li>Complete system-on-chip, no calibration required</li> </ul>	<ul style="list-style-type: none"> <li>360° contactless angular position sensing</li> </ul>
<ul style="list-style-type: none"> <li>Multiple data output formats</li> </ul>	<ul style="list-style-type: none"> <li>Serial synchronous interface</li> <li>Pulse width modulated output (PWM)</li> <li>Incremental output formats</li> </ul>

Benefits	Features
<ul style="list-style-type: none"> <li>• Ideal for applications in harsh environments due to magnetic sensing principle</li> </ul>	<ul style="list-style-type: none"> <li>• High reliability due to non-contact sensing</li> </ul>
<ul style="list-style-type: none"> <li>• Robust system, tolerant to horizontal misalignment, airgap variations, temperature variations and external magnetic stray fields</li> </ul>	<ul style="list-style-type: none"> <li>• Wide magnetic field input range: 20 – 80 mT (typical)</li> <li>• Wide temperature range: -40°C to 150°C</li> <li>• Fully automotive qualified to AEC-Q100, grade 0</li> </ul>

## Applications

The AS5132 is suitable for:

- Contactless rotary position sensing
- Rotary switches (human machine interface)
- AC/DC motor position control
- Brushless DC motor position control

### Block Diagram

The functional blocks of this device are shown below:

**Figure 2:**  
AS5132 Block Diagram

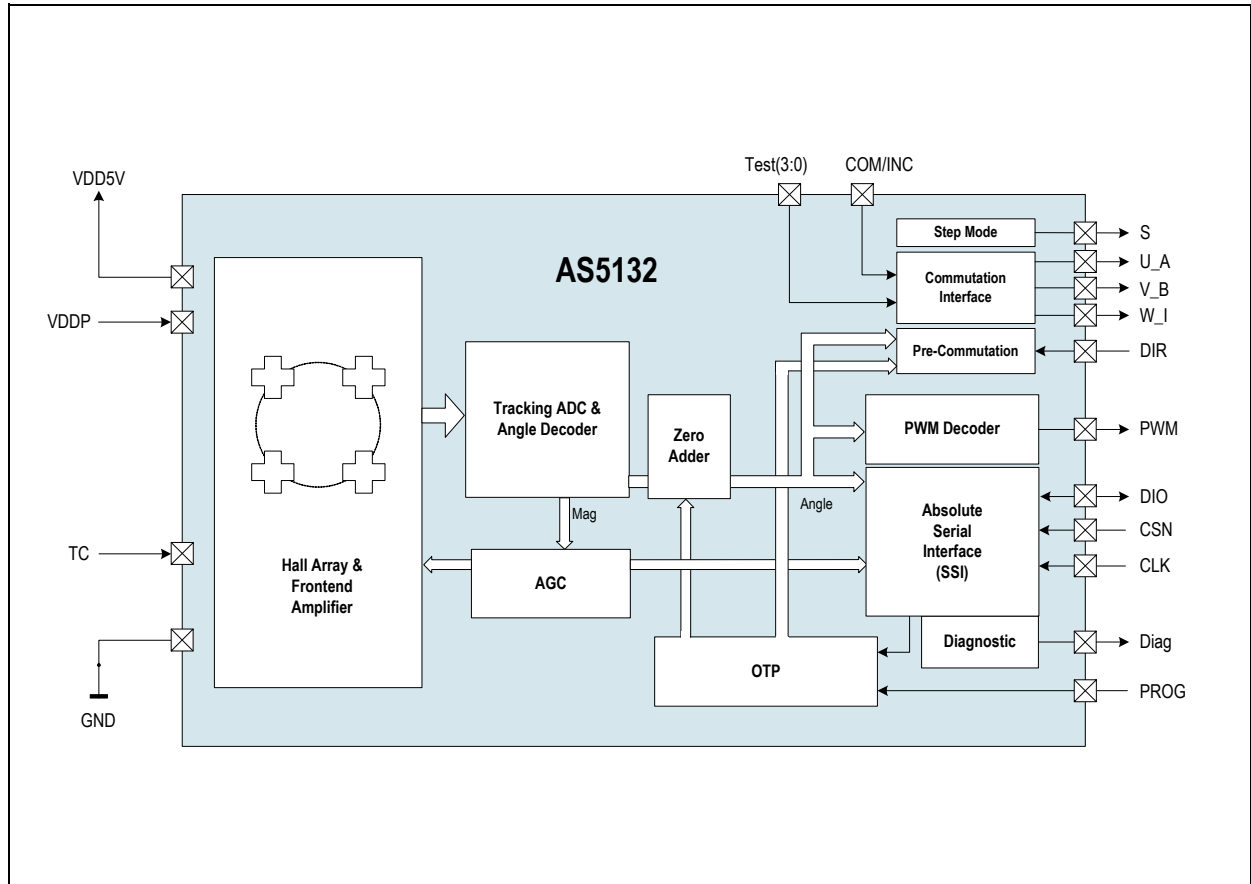

### Pin Assignment

The AS5132 pin assignments are described below.

**Figure 3:**  
Pin Diagram

**Pin Assignments (Top View):**  
Package drawing is not to scale.

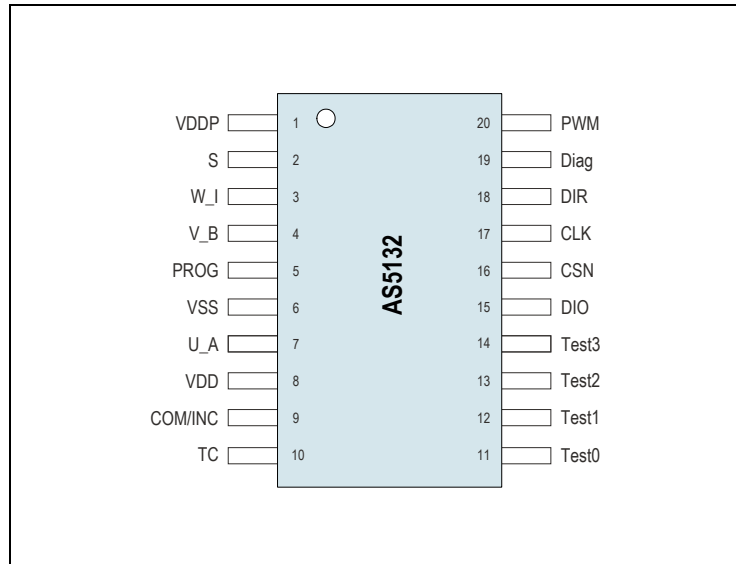

**Figure 4:**  
Pin Description

Pin Number	Pin Name	Pin Type	Description
1	VDDP	Supply	Supply voltage for the selected pins <sup>(1)</sup>
2	S	Digital output	Step output (8mA, VDDP)
3	W_I		Commutation output or incremental output
4	V_B		
5	PROG	Analog Input / Output	Programming voltage input. Do not connect this pin to VSS. Connectivity for programming see <a href="#">Figure 24</a>
6	VSS	Supply	Supply ground
7	U_A	Digital output	Commutation output or incremental output
8	VDD	Supply	Positive supply voltage
9	COM / INC	Digital input / Schmitt-Trigger	Selection of the output mode. This pin is also used for external clock mode (VDDP)
10	TC	Analog input	Test pin. Connect to VSS in application

Pin Number	Pin Name	Pin Type	Description
11	Test0	Analog input /output	Test pin, selection of output format for incremental or step mode
12	Test1		
13	Test2		
14	Test3		
15	DIO	Bi-directional digital	Data I/O for serial interface (VDDP)
16	CSN	Digital input / Schmitt-Trigger	Chip select input (active low) (VDDP) (connected to a pull-up resistor if not used in application)
17	CLK		Clock input for serial interface (VDDP)
18	DIR		Input signal for the pre-commutation at start-up (VDDP)
19	Diag	Digital output / Open Drain	Diagnostic output (open drain)
20	PWM	Digital output	PWM output (8mA, VDDP)

**Note(s):**

1. VDDP can be customized to the voltage levels of the peripheral circuitry to economize voltage level drivers.
2. Typ. CSN Pull\_up resistor of 10kOhm necessary. Floating state of a digital input is not allowed.

## Absolute Maximum Ratings

Stresses beyond those listed in [Absolute Maximum Ratings](#) may cause permanent damage to the device. These are stress ratings only, and functional operation of the device at these or any other conditions beyond those indicated in [Electrical Characteristics](#) is not implied. Exposure to absolute maximum rating conditions for extended periods may affect device reliability.

**Figure 5:**  
Absolute Maximum Ratings

Symbol	Parameter	Min	Max	Units	Comments
<b>Electrical Parameters</b>					
V <sub>DD</sub>	Supply voltage	-0.3	7	V	Except during OTP programming
V <sub>DDP</sub>	DC supply voltage	0.3	7	V	Cannot be higher than V <sub>DD</sub> +0.3
V <sub>IN</sub>	Input pin voltage	V <sub>SS</sub> -0.5	V <sub>DD</sub>	V	
I <sub>scr</sub>	Input current (latch up immunity)	-100	100	mA	Norm: EIA/JESD78 Class II Level A
<b>Electrostatic Discharge</b>					
ESD <sub>HBM</sub>	Electrostatic discharge	±2		kV	Norm: JESD22-A114E
<b>Temperature Ranges and Storage Conditions</b>					
T <sub>strg</sub>	Storage temperature	-55	150	°C	
T <sub>body</sub>	Body temperature		260	°C	The reflow peak soldering temperature (body temperature) specified is in accordance with <i>IPC/JEDEC J-STD-020 "Moisture/Reflow Sensitivity Classification for Non-Hermetic Solid State Surface Mount Devices"</i> . The lead finish for Pb-free leaded packages is matte tin (100% Sn).
RH <sub>NC</sub>	Relative humidity (non-condensing)	5	85	%	
MSL	Moisture sensitivity level	3			Represents a maximum floor time of 168h

## Electrical Characteristics

All limits are guaranteed. The parameters with min and max values are guaranteed with production tests or SQC (Statistical Quality Control) method.

$T_{AMB} = -40^{\circ}\text{C}$  to  $150^{\circ}\text{C}$ ,  $V_{DD} = 4.5\text{V}$  to  $5.5\text{V}$ , all voltages referenced to  $V_{SS}$ , unless otherwise noted.

## Operating Conditions

**Figure 6:**  
Operating Conditions

Symbol	Parameter	Conditions	Min	Typ	Max	Units
$V_{DD}$	Positive supply voltage		4.4		5.5	V
$V_{DDP}$	Positive supply voltage periphery		3.0		5.5	V
$I_{DD}$	Operating current	No load on outputs. Supply current can be reduced by using stronger magnets.		15	22	mA

## System Parameters

**Figure 7:**  
System Parameters

Symbol	Parameter	Conditions	Min	Typ	Max	Units
N	Resolution			8.5		Bit
				1		Deg
$T_{PwrUp}$	Power up time				$\leq 4100$	$\mu\text{s}$
$t_s$	Tracking rate	Step rate of tracking ADC; 1 step = $1^{\circ}$			5.2	$\mu\text{s}/\text{step}$
$INL_{cm}$	Accuracy	Centered magnet	-2		2	Deg
		Within horizontal displacement radius	-3		3	
$t_{delay}$	Propagation delay	Internal signal processing time			22	$\mu\text{s}$
TN	Transition noise	peak-peak			1.41	Deg

## Magnet Specifications

**Figure 8:**  
Magnet Specifications

Symbol	Parameter	Conditions	Min	Max	Units
$B_Z$	Magnetic input range	At die surface	20	80	mT
$V_i$	Magnet rotation speed	To maintain locked state <sup>(1)</sup>		72,900	rpm

**Note(s):**

- Maximum rotation speed is dependent on the internal time reference.  
Maximum value is calculated with lowest sequence over all operating conditions.

## Programming Parameters

**Figure 9:**  
Programming Parameters

Symbol	Parameter	Conditions	Min	Max	Units
$V_{PROG}$	Programming voltage	Static voltage at pin PROG	8	8.5	V
$I_{PROG}$	Programming current	During programming		100	mA
$T_{ambPROG}$	Programming ambient temperature		0	85	°C
$t_{PROG}$	Programming time		2	4	μs
$V_{R,prog}$	Analog readback voltage	During analog readback mode at pin PROG		0.5	V
$V_{R,unprog}$			2	3.5	

## DC Characteristics of Digital Inputs

**Figure 10:**  
CMOS Inputs COM/INC, CSN, CLK, DIO, DIR

Symbol	Parameter	Min	Max	Units	Note
$V_{IH}$	High level input voltage	$0.7 \cdot V_{DDP}$	$V_{DDP}$	V	COM/INC refer to VDD
$V_{IL}$	Low level input voltage	0	$0.3 \cdot V_{DDP}$	V	
$I_{LEAK}$	Input leakage current		1	μA	



## DC Characteristics of Digital Outputs

**Figure 11:**  
CMOS Outputs S, U\_A, V\_B, W\_I, PWM, DIO

Symbol	Parameter	Min	Max	Units	Note
V <sub>OH</sub>	High level output voltage	VDDP-0.5	VDDP	V	PWM and S have 8mA output load, DIO has 4mA output load.
		VDD-0.5	VDD		U_A, V_B, W_I have 4mA output load.
V <sub>OL</sub>	Low level output voltage	0	VSS+0.4	V	PWM and S have 8mA output load, DIO, U_A, V_B, W_I has 4mA output load.
CL	Capacitive load		35	pF	

## Timing Characteristics

**Figure 12:**  
Timing Characteristics

Symbol	Parameter	Min	Typ	Max	Units
f <sub>CLK</sub>	Clock frequency normal operation		5	6	MHz
f <sub>CLKP</sub>	Clock frequency during OTP programming	200		650	kHz
t <sub>1</sub>	CSn to positive edge of CLK	150			ns
t <sub>2</sub>	CSn to drive bus externally	0			ns
t <sub>3</sub>	Setup time command bit (data valid to positive edge of CLK)	50			ns
t <sub>4</sub>	Hold time command bit (data valid after positive edge of CLK)	15			ns
t <sub>5</sub>	Float time (positive edge of CLK for last command bit to bus float)			0.5 * 1/f <sub>CLK</sub>	ns
t <sub>6</sub>	Bus driving time (positive edge of CLK for last command bit to bus drive)	0.5 * 1/f <sub>CLK</sub>			ns
t <sub>7</sub>	Data valid time (positive edge of CLK to bus valid)	0.5 * 1/f <sub>CLK</sub>		0.5 * 1/f <sub>CLK</sub> + 50	ns
t <sub>8</sub>	Hold time data bit (data valid after positive edge of CLK)	0.5 * 1/f <sub>CLK</sub>			ns

Symbol	Parameter	Min	Typ	Max	Units
$t_9$	Hold time CSn (positive edge of last CLK to negative edge of CSn)	$0.5 * 1/f_{CLK}$			ns
$t_{10}$	Bus floating time (positive edge of CSn to float bus)			50	ns
$t_{11}$	Setup time data bit @ write access (data valid to positive edge of CLK)	50			ns
$t_{12}$	Hold time data bit @ write access (data valid after positive edge of CLK)	15			ns
$t_{13}$	Bus floating time (positive edge of CSn to float bus)			50	ns
$t_{14}$	CSn high time	2			$\mu$ s

## Detailed Description

**Figure 13:**  
Typical Arrangement of AS5132 and Magnet

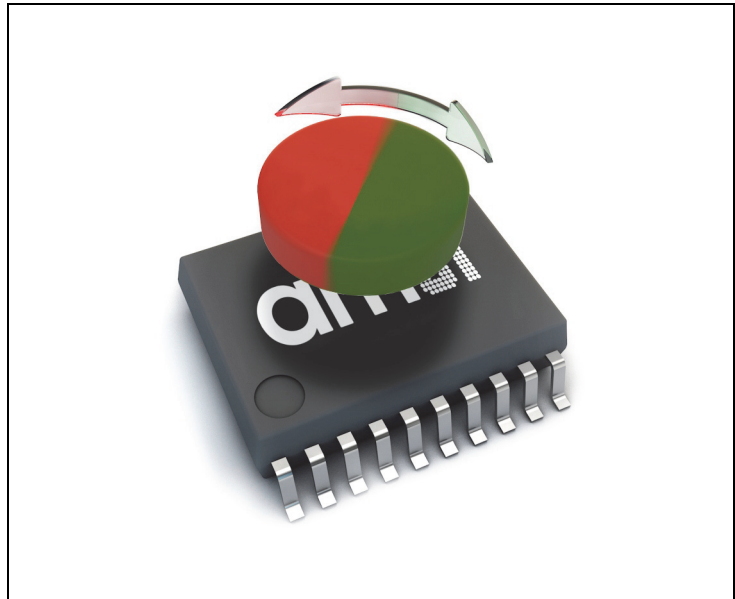

### Synchronous Serial Interface (SSI)

The absolute angle data can be read out over the synchronous serial interface using the pins **CSN**, **DIO** and **CLK**. It is a bidirectional interface therefore a read or write access is possible. The organization of the protocol is byte wise and starts with the command byte followed by the data information.

**Figure 14:**  
Read / Write Serial Data Transmission

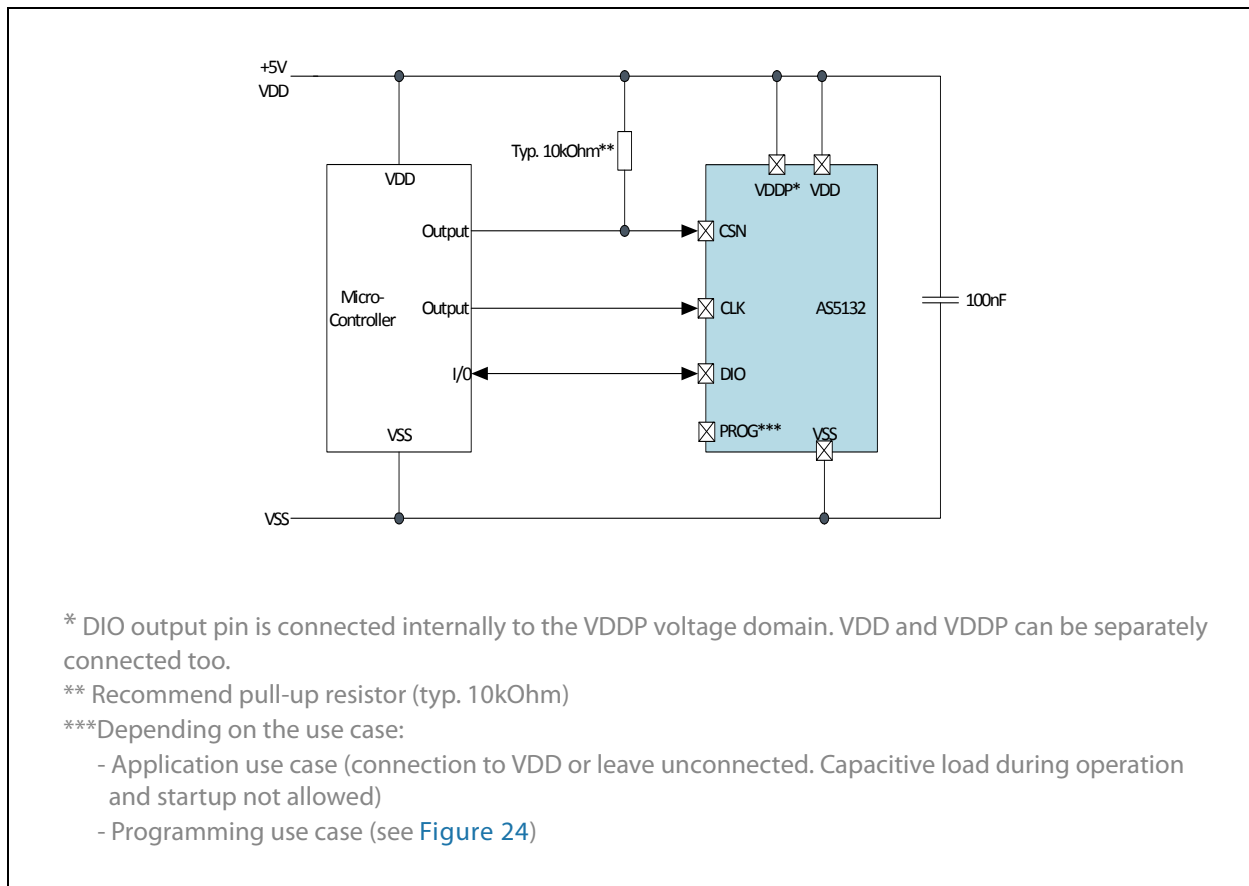

Figure 14 shows the connection of the AS5132 to a micro controller. Depending on the command byte are different access types possible. In normal mode the number of clocks is equal the number of data bits.

**Figure 15:**  
Data Organization of the SSI Protocol 16-Bit Data

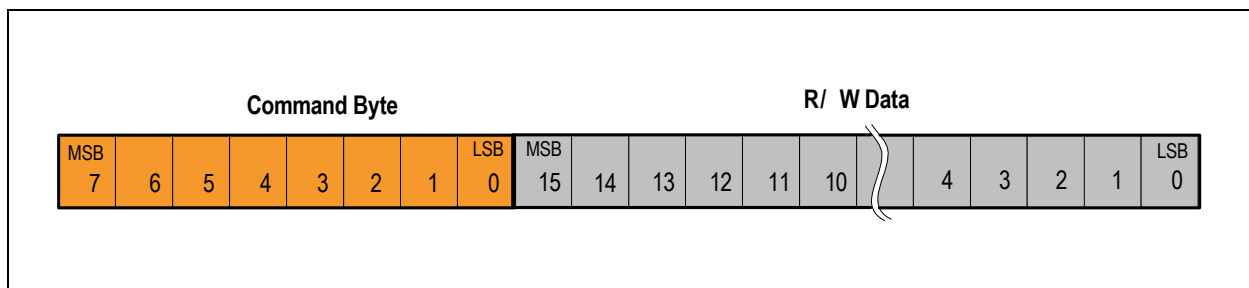
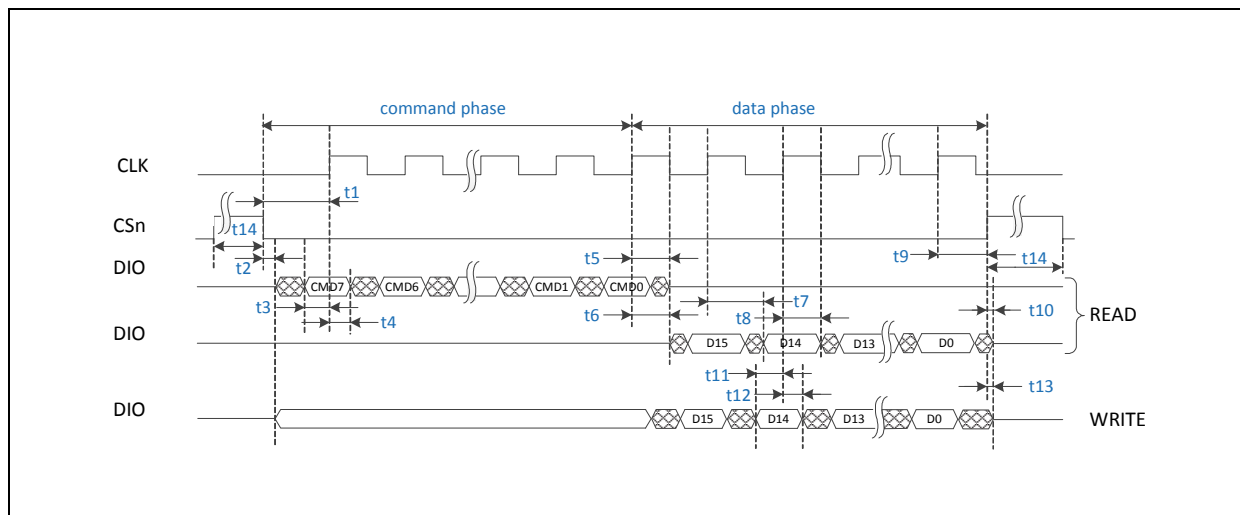

Figure 15 shows the organization of the data. The first section is used to setup the operating mode and the address. During write mode the micro controller drives the data line and generates in addition the CSn and CLK signal. Figure 16 shows SSI Read and write operations in normal mode.

**Figure 16:**  
SSI Normal Read and Write Mode



The first 8 command data bits are written by the microcontroller. After the command data the device takes over the **DIO** line and writes the data information. A high impedance phase must be considered before the device drives the output line.

**Commands of the SSI in Normal Mode**

**Figure 17:**  
Read/Write Interface Commands in Normal Mode

Command Name	Command Data	Access Mode	MSB 15	14	13	12	11	10	9	8	7	6	5	4	3	2	1	LSB 0	
WRITE CONFIG	0001_0111	write		GEN RST	Hyst Dis	PRE_COM_DYN<5:0>					MTC2	MTC1							
SET MT COUNTER	0001_0100	write	MT - COUNTER <8:0>																
EN PROG	1000_0100	write	0	1	1	0	0	1	0	1	0	1	1	1	0	0	0	0	
RD MT COUNTER	0000_0100	read	MT - COUNTER <8:0>								EZ ERR								P
RD_ANGLE	0000_0000	read	ANGLE <8:0>								LOCK ADC	AGC <5:1>					P		

**Note(s):**

- 1. Gray bits can be ignored by the user.

**GEN RST:** A HI generates a reset of the AS5132. GEN RST must be set to LO after reset.

**Hyst\_Dis:** Hysteresis disable.

**PRE\_COM\_DYN <5:0>:** Absolute dynamic pre-commutation value. Depending on the setup of the pole pairs, a mechanical angle offset can be adjusted. The range is 0 to 63 mechanical degrees (LSBs).

**MT-COUNTER <8:0>:** The multiturn counter can be set or read over the interface.

**EN PROG:** This command with the data content enables the access to the OTP register in extended mode. OTP Programming mode is only possible in extended mode with special connection Figure 24 on page 18.

**EZ ERR:** Indicates a wrong operation of the OTP memory after programming at room temperature. This bit is not intended for OTP diagnostic in the application over life time. This bit lose also validity over a time.

**ANGLE <8:0>:** Absolute angle information with angular true resolution (360 steps).

**LOCK ADC:** Indicates a locked ADC. An angle value is only valid in case of a locked ADC. During sleep mode is the LOCK ADC bit LO.

**AGC <5:1>:** Automatic gain control value indicates the magnetic field strength.

**P:** Parity information of the 15 data bits. Odd parity.

### Extended Synchronous Serial Interface Mode

The absolute angle data can be read out over the synchronous serial interface using the pins **CSN**, **DIO** and **CLK**. It is a bidirectional interface therefore a read or write access is possible. The organization of the protocol is byte wise and starts with the command byte followed by the data information.

**Figure 18:**  
Connectivity During Programming in Extended Mode

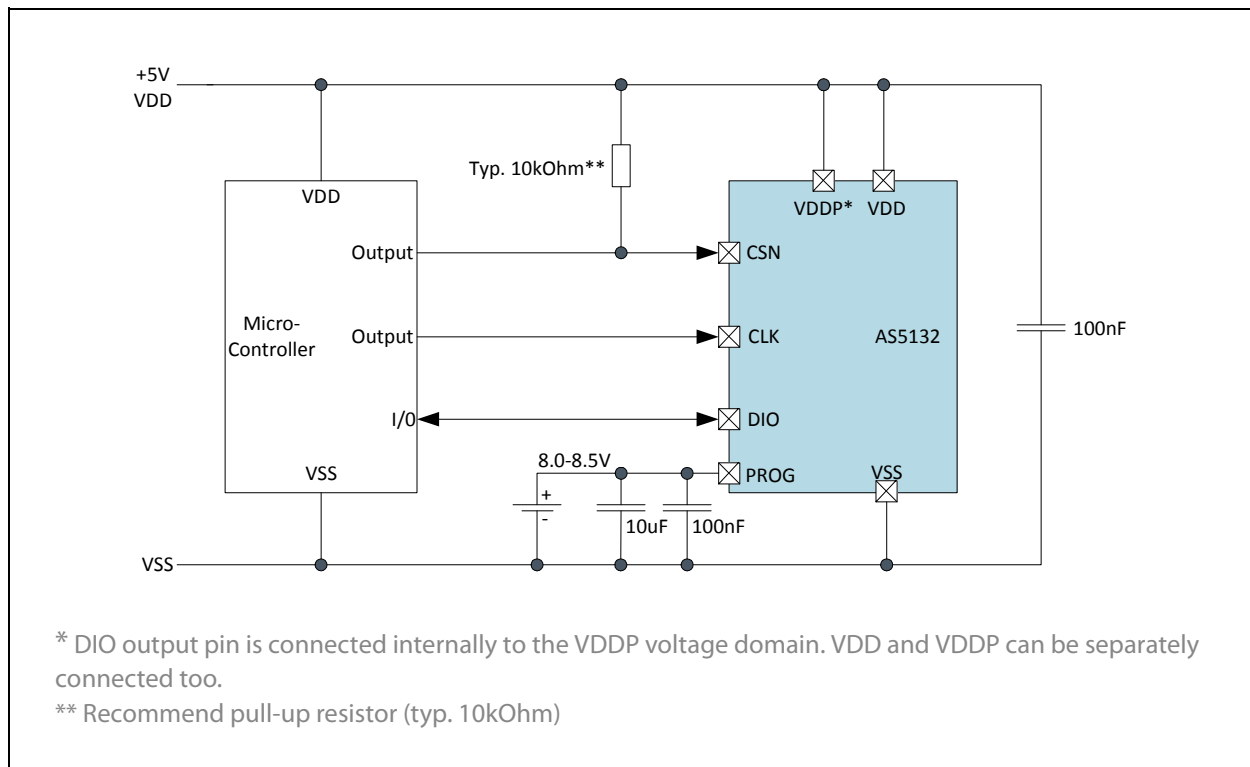

**Figure 19:**  
SSI Extended Read and Write Mode

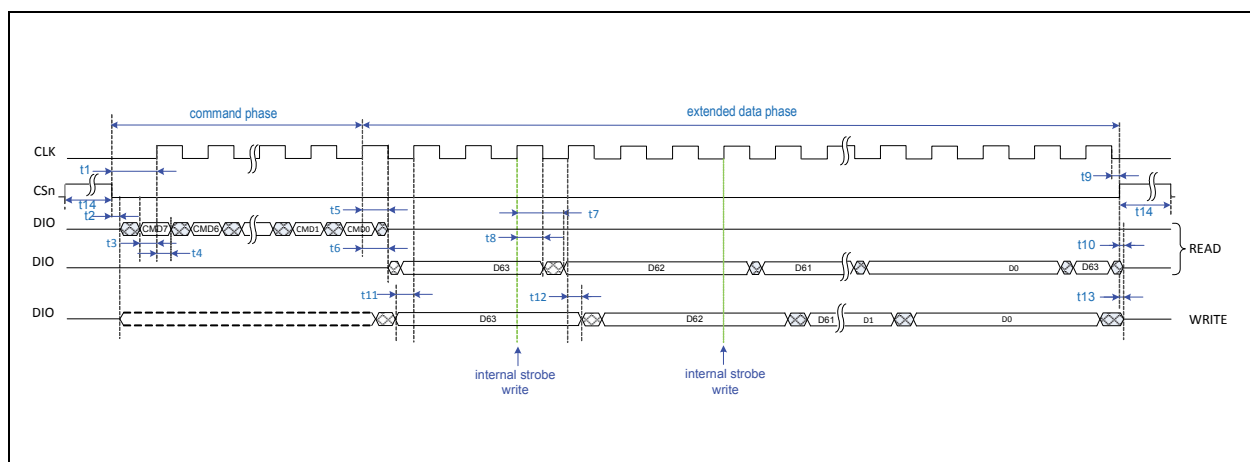

In extended mode the digital interface requires four clocks per data bit. During this time the device is able to handle internal signals for special access.

**Figure 20:**  
Read/Write Interface Commands in Extended Mode

Command Name	Command Data	Access Mode	MSB 63	...	17	16	15	14	13	12	11	10	9	8	...	LSB 0
WRITE OTP	0001_1111	ext. write	TST<46:0>			SENSITIVITY <1:0>		ext. CLK EN	PRE_COM_STAT <1:0>	UVW <2:0>			ZERO ANGLE <8:0>			
PROG OTP	0001_1001	ext. write	TST<46:0>			SENSITIVITY <1:0>		ext. CLK EN	PRE_COM_STAT <1:0>	UVW <2:0>			ZERO ANGLE <8:0>			
READ OTP	0000_1111	ext. write	TST<46:0>			SENSITIVITY <1:0>		ext. CLK EN	PRE_COM_STAT <1:0>	UVW <2:0>			ZERO ANGLE <8:0>			
READ ANA	0000_1001	ext. read	TST<46:0>			SENSITIVITY <1:0>		ext. CLK EN	PRE_COM_STAT <1:0>	UVW <2:0>			ZERO ANGLE <8:0>			

**Note(s):**

1. TST is pre-programmed by ams AG and used for test purpose.

*Programming Parameters*

**ZERO ANGLE <8:0>:** Zero position value. This value is permanent added to the internal absolute position. Use range 0 to 359.

**UVW <2:0>:** Setup of the number of pole pairs. In the step mode configuration, the bit UVW<2> is used to invert the step mode output signal.

**Figure 21:**  
Possible Settings for UVW Outputs

UVW <2:0>			Number of Pole Pairs
0	0	0	1
0	0	1	2
0	1	0	3
0	1	1	4
1	0	0	5
1	0	1	6
1	1	0	6
1	1	1	6



**SENSITIVITY <1:0>:** Setup of the amplification within the internal signal path. The sensitivity adjustment can be used to center the AGC value at default conditions.

**Figure 22:**  
Setup of the Sensitivity

SENSITIVITY <1:0>		Sensitivity Setting		
		Min	Typ	Max
0	0	1.6	1.65	1.75
0	1	1.79	1.88	1.98
1	0	2.01	2.11	2.22
1	1	2.23	2.35	2.47

**Figure 23:**  
Setup Parameters for the Static Pre-Commutation

PRE_COM_STAT <1:0>		Static Pre-commutation Value in Mechanical Degrees
0	0	0
0	1	2
1	0	4
1	1	8

**Ext. CLK EN:** Enables the external CLK mode for the PWM output. The external CLK mode is only possible in commutation mode. The state of the pin COM/INC is not considered in this case for mode selection.

**Figure 24:**  
**OTP Programming Connection**

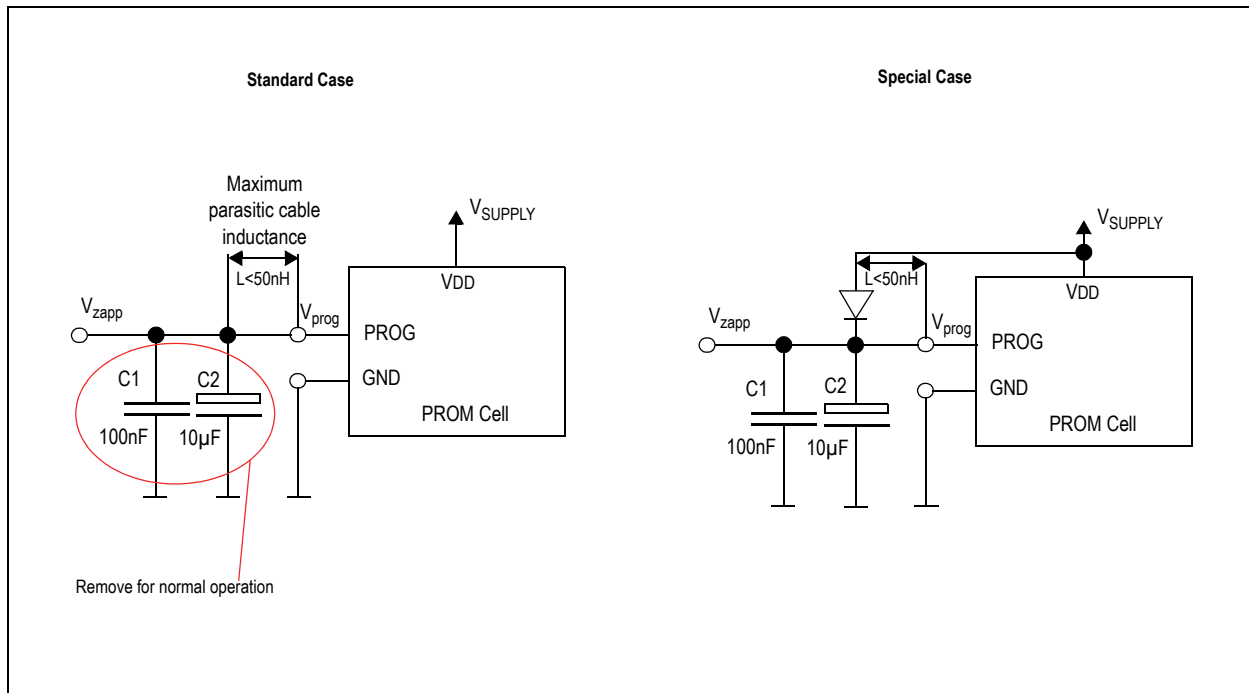

The maximum capacitive load at PROG in normal operation should be less than 20pF. However, during programming the capacitors C1+C2 are needed to buffer the programming voltage during current spikes, but they must be removed for normal operation. To overcome this contradiction, the recommendation is to add a diode (4148 or similar) between PROG and VDD as shown in [Figure 24](#) (special case setup), if the capacitors can not be removed at final assembly. Due to D1, the capacitors C1+C2 are loaded with  $V_{DD}-0.7V$  at startup, hence not influencing the readout of the internal OTP registers. During programming the OTP, the diode ensures that no current is flowing from PROG (8V to 8.5V) to VDD (5V). In the standard case (see [Figure 24](#)), the verification of a correct OTP readout must be done by analog readback. The special case setup provides the analog readback of the OTP as well. As long as the PROG pin is accessible it is recommended to use standard setup. In case the PROG pin is not accessible at final assembly, the special setup is recommended.

### Programming Verification

The verification of the OTP programming is mandatory using following methods:

**Digital Verification:** Checking the EZ\_ERR bit (0 = OK, 1 = error)

- Restricted to temperature range: 25 °C ± 20 °C
- Right after the programming (max. 1 hour with same conditions 25°C ± 20 °C)

Figure 25 shows the correct digital verification flow. The EZ\_ERR bit is valid only after a power on reset. This bit becomes invalid after a OTP write or read access.

**Figure 25:**  
Programming & Digital Verification Flow

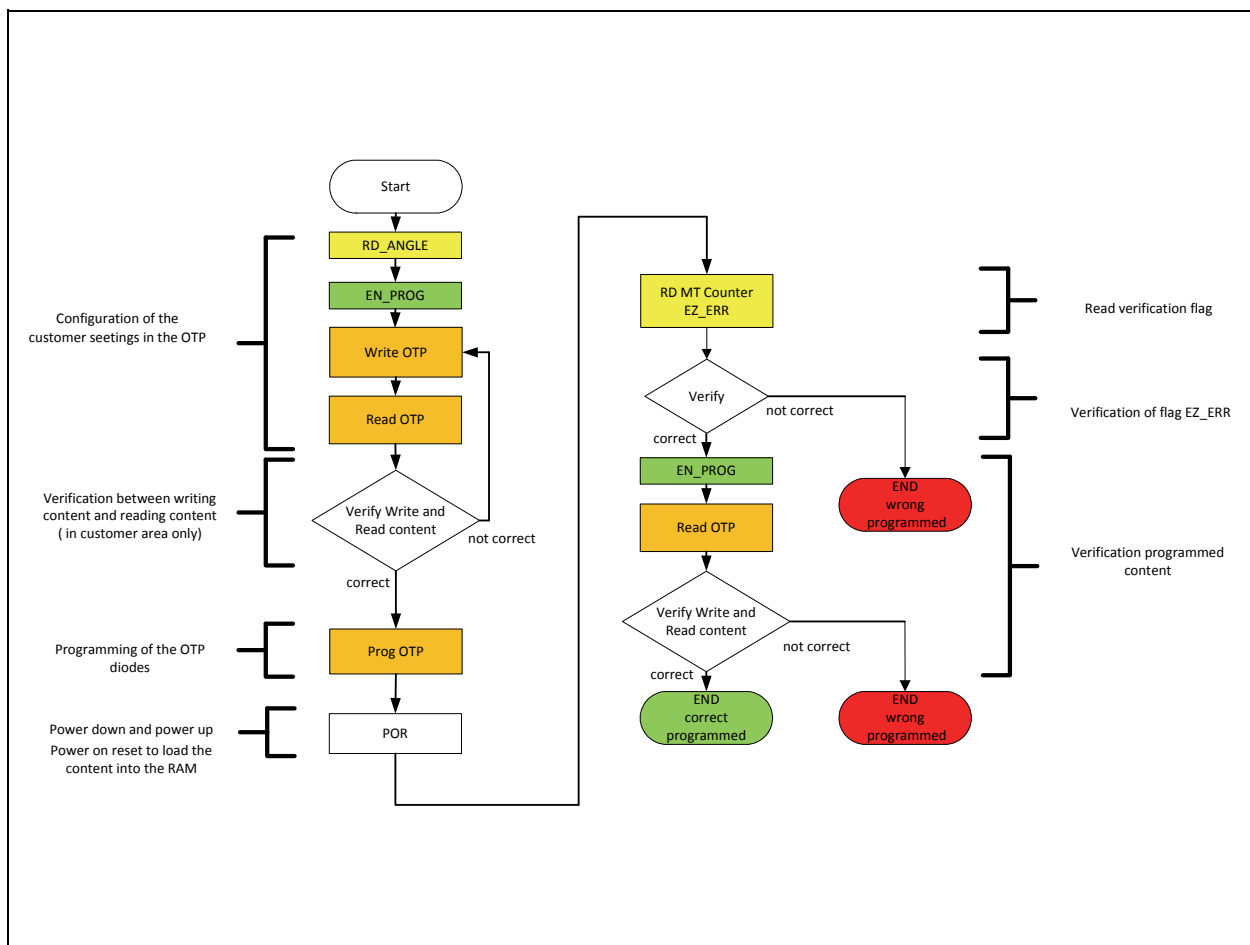

**Analog Verification:** By switching into Extended Mode and sending a READ ANA command, the pin PROG becomes an output sending an analog voltage with each clock representing a sequence of the bits in the OTP register (starting with D61). A voltage of <500mV indicates a correctly programmed bit ("1") while a voltage level between 2V and 3.5V indicates a correctly unprogrammed bit ("0"). Any voltage level in between indicates incorrect programming.

**Figure 26:**  
Analog OTP Verification

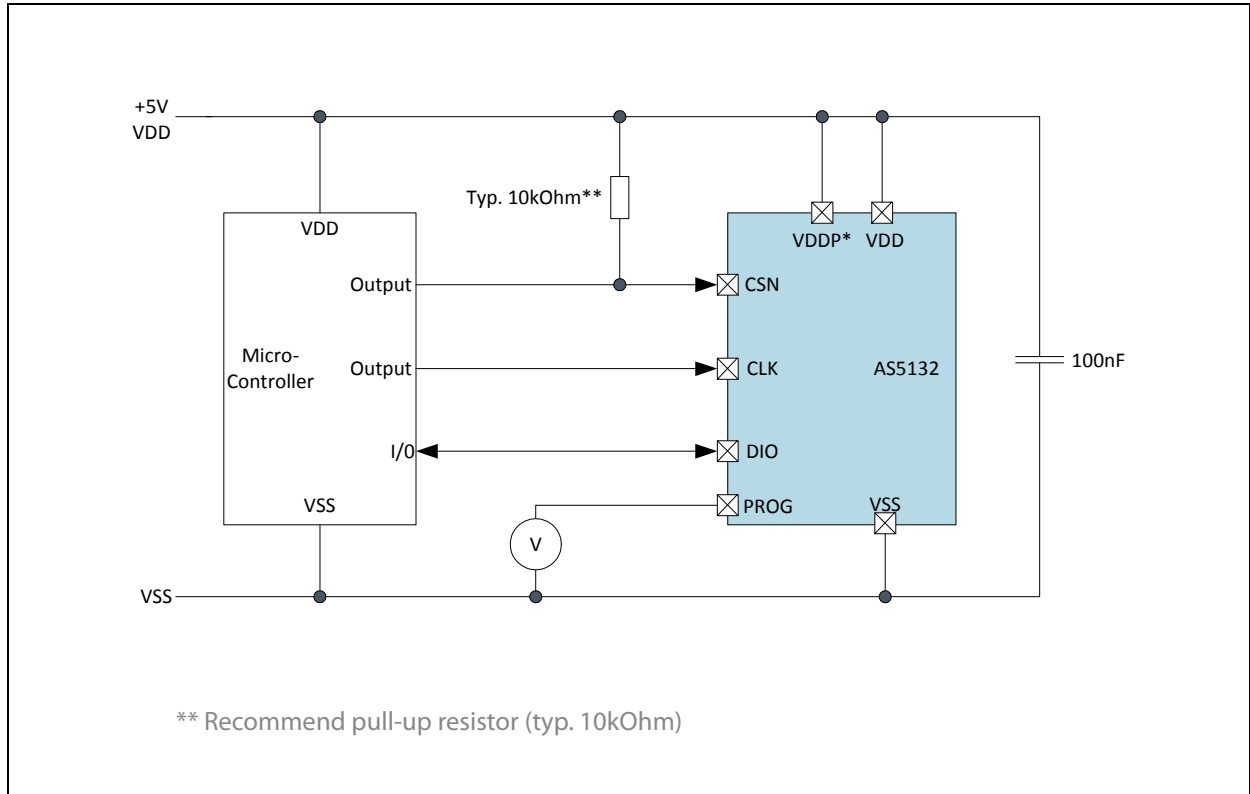

## Pulse Width Modulation (PWM) Output

The AS5132 provides a pulse width modulated output (PWM), whose duty cycle is proportional to the absolute angle position. [Figure 29](#) shows the output format. In case of an internal error the high pulse contains 12 steps. An error can be easily identified by the external microcontroller. The zero degree angle position is build with 16 steps (12 + 4) high and 359 steps low followed by 8 exit steps.

**Figure 27:**  
PWM Output

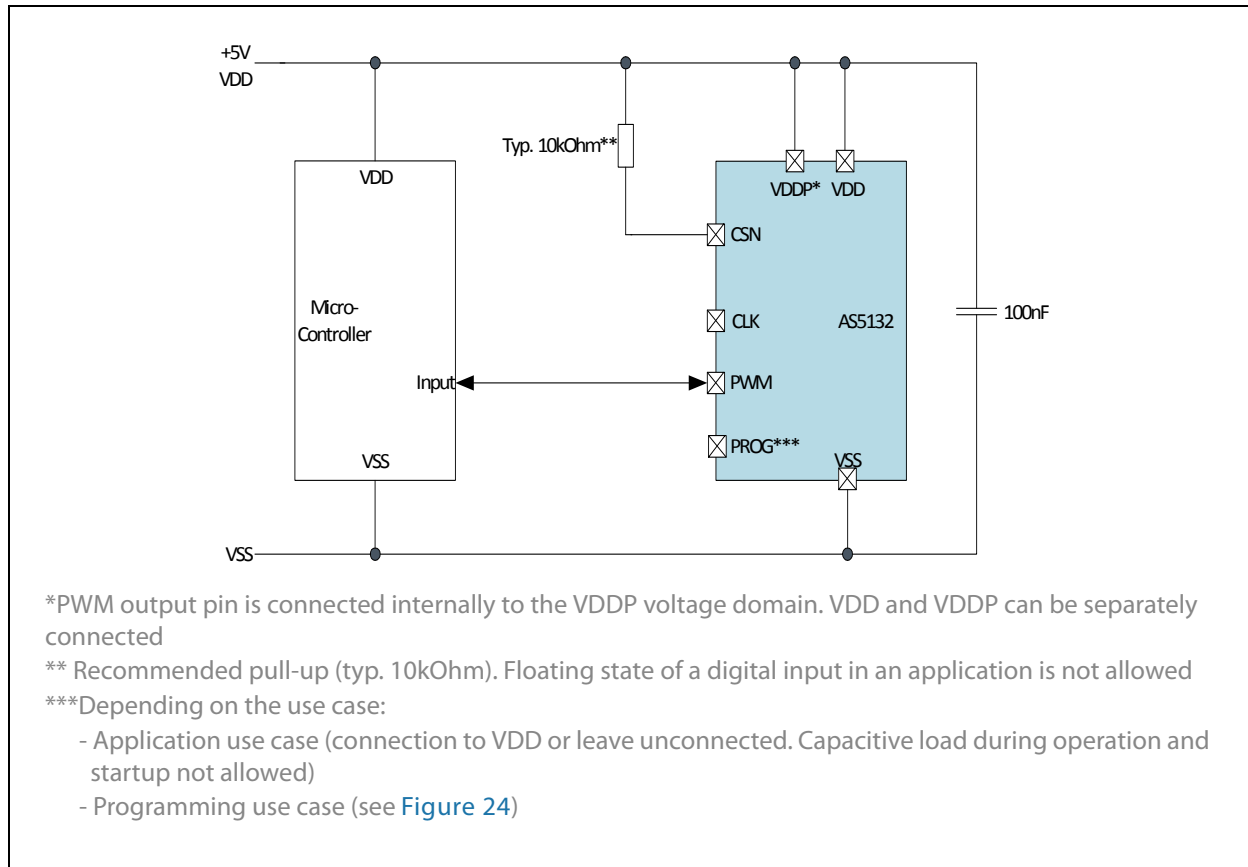

## PWM External Clock

The PWM period depends on the setting of the OTP bit **Ext. CLK EN**. By default the internal clock source is used as a reference. An external clock can be connected to the pin COM/INC.

In case Ext. CLK EN is set, the output-mode which is determined by the states of {COM/INC, Test3, Test2, Test1, Test0} [Figure 31](#) on page 23 during start-up is overwritten and U,V,W commutation mode signals are activated.

After internal power on reset (POR\_en), the OTP is read out. When the Ext. CLK EN is programmed successfully, the COM/INC pin is used as external clock for the PWM block. After 4 clock cycles of Ext. CLK EN, the reset of TADC (TADC\_rst) and the PWM block is released.

**Figure 28:**  
Start-Up Procedure

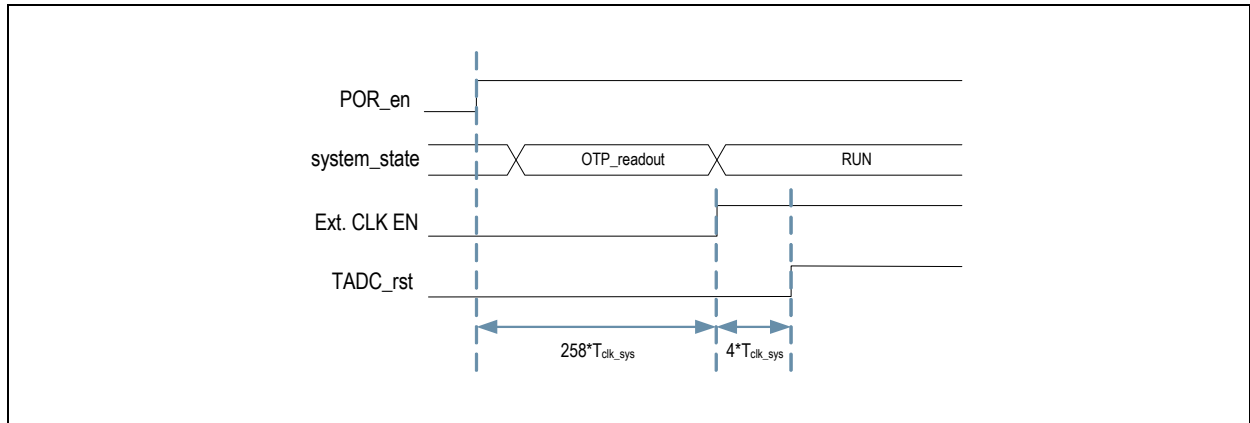

The reset for the PWM block is synchronized to the external PWM clock. This ensures a save reset also in case the external clock on COM/INC is already running during start-up.

**Figure 29:**  
PWM Output Signal

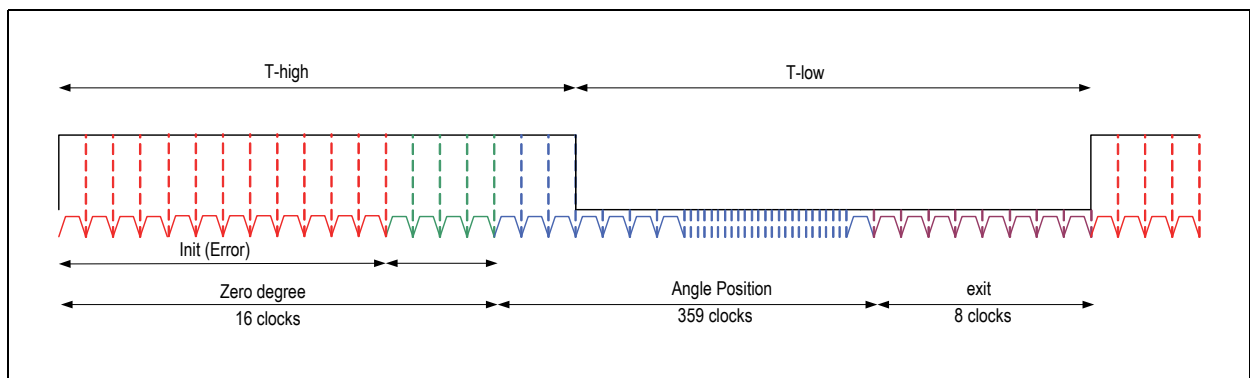

**Figure 30:**  
PWM Timing with Internal and External CLK Source

Symbol	Parameter	Min	Typ	Max	Unit	Note
$T_{PWMint}$	PWM Period internal	600	750	900	$\mu s$	Internal clock source
$T_{PWMext}$	PWM Period external	383 / $CLK_{PWM}$			$\mu s$	External clock provided over COM / INC pin
$CLK_{PWM}$	Clock external mode	0		766	kHz	

## Incremental Outputs

Two different incremental output modes are possible. Quadrature A/B mode and selectable Step Mode can be selected by the pins **TEST0**, **TEST1**, **TEST2**, **TEST3** and **COM / INC**.

**Figure 31:**  
Configuration of the Incremental Output Modes

COM / INC	TEST3	TEST2	TEST1	TEST0	Output Mode	Pin Assignment
1	0	0	0	0	Quadrature A/B/I Mode 90 pulses per channel	A → U_A B → V_B I → W_I '0' → S
1	0	0	0	1	Stepmode 24 pulses and Index width 2	'0' → U_A '0' → V_B '0' → W_I S_24_2 → S
1	0	0	1	0	Stepmode 60 pulses and Index width 2	'0' → U_A '0' → V_B '0' → W_I S_60_2 → S
1	0	0	1	1	Stepmode 90 pulses and Index width 2	'0' → U_A '0' → V_B '0' → W_I S_90_2 → S
1	0	1	0	0	Stepmode 180 pulses and Index width 2	'0' → U_A '0' → V_B '0' → W_I S_180_2 → S
0	0	0	0	0	U,V,W Commutation Mode (OTP setting)	U → U_A V → V_B W → W_I '0' → S

**Note(s):**

1. The pin setting COM / INC has priority. In case of a low state the device is exclusively in the commutation mode. Not specified states of TEST3, TEST2, TEST1 and TEST0 in incremental mode will enable the quadrature A/B/I mode. This configuration is only read once at startup. It is not recommended to change the state during operation.

### Quadrature A/B Output

**Figure 32:**  
Incremental Output of the AS5132

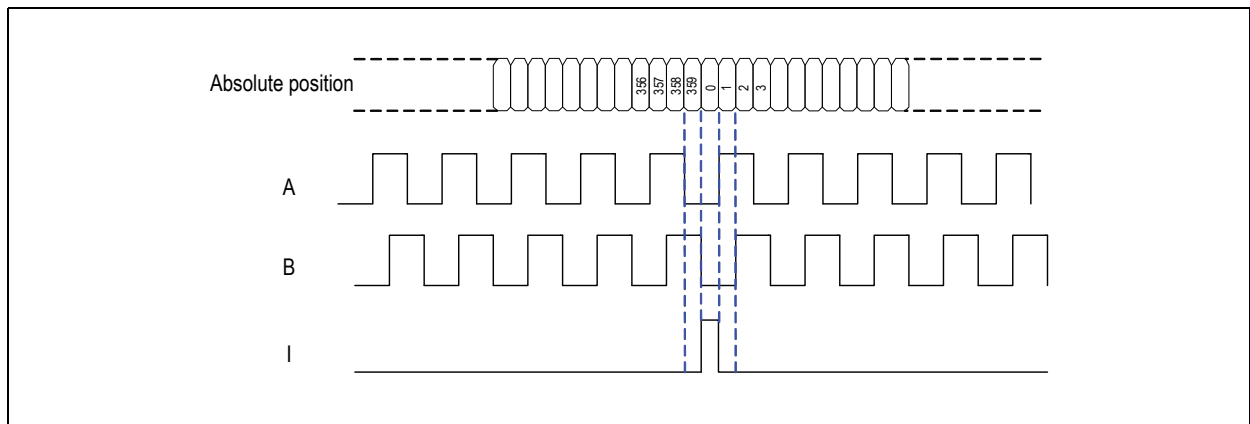

Figure 32 shows the two-channel quadrature output. The index position is mapped to the absolute mechanical zero position. The phase shift between channel A and B indicates the direction of the magnet movement. Channel A leads channel B at a clockwise rotation of the magnet (top view) by 90 electrical degrees. Channel B leads channel A at a counter-clockwise rotation.



### Step Output Mode

Step Output mode provides a specific combination of the **A** incremental signal and the index signal **I**. The number of pulse can be configured with the input pattern of the test input pins.

**Figure 33:**  
Step Mode of the AS5132 with Different Number of Pulses

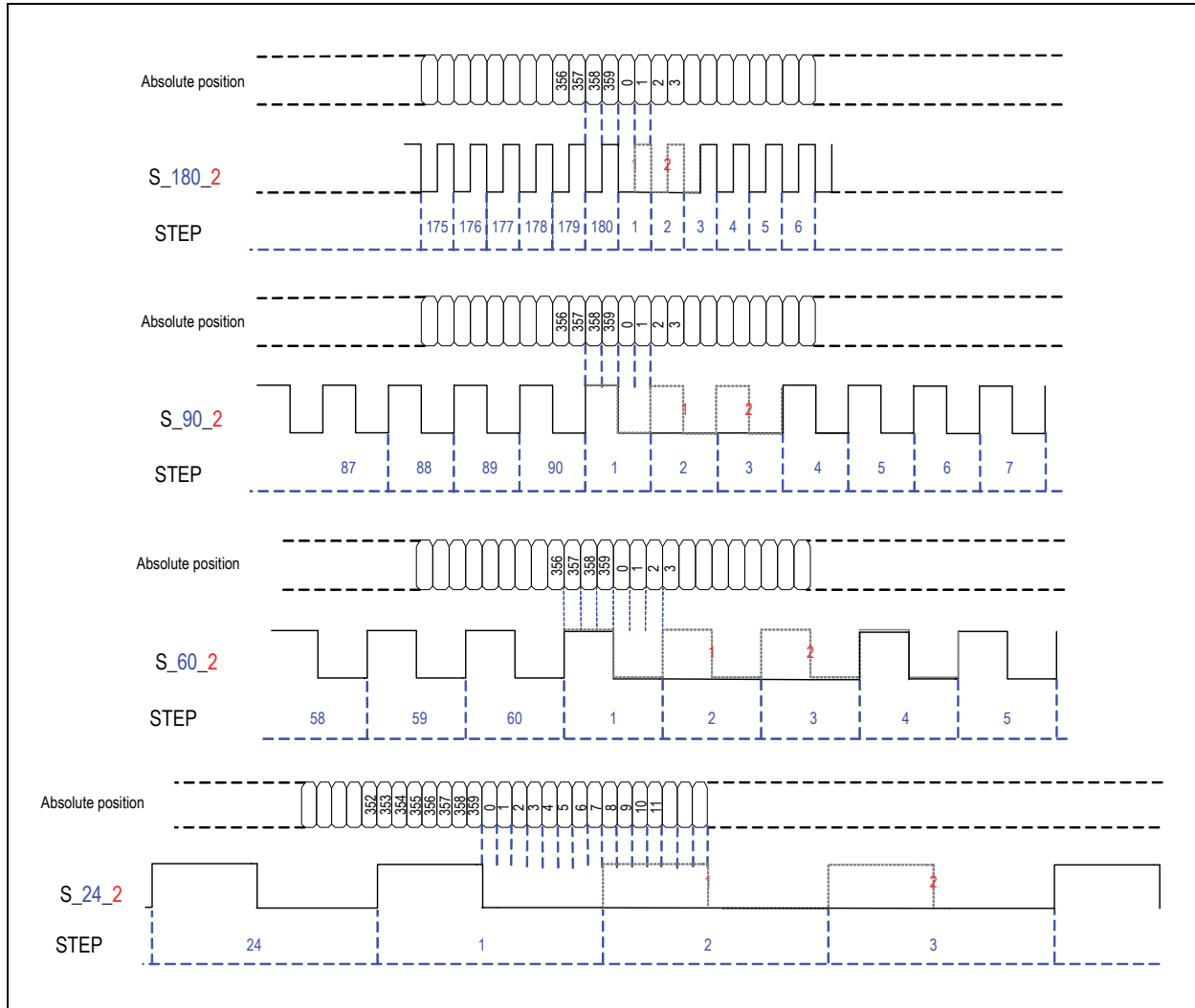

**Pre-Commutation Function**

This feature can be used to optimize the torque characteristic at a certain speed of the BLDC motor. The output signals **U**, **V** and **W** can be shifted by a specific number of degrees back and forward. The AS5132 distinguish between the static and dynamic pre commutation value. The static value is similar to an additional zero programming and can be programmed only once. The dynamic value is stored in the interface register and can be changed during operation.

The pin **DIR** defines if the value of pre-commutation is added or subtracted. The dynamic commutation register will be set to zero after a rotation change indicated by the external pin **DIR**. Due to internal synchronization, the outputs U,V,W will change 3 internal clock cycles after the change of **DIR** input signal.

**Figure 34:**  
Definition of the Pre-Commutation Direction

DIR	Rotation	Consequence
0	Clock wise	PRE_COM values added to absolute angle
1	Counter clock wise	PRE_COM values subtracted from absolute angle

**Figure 35:**  
Block Diagram of the Pre-Commutation Function

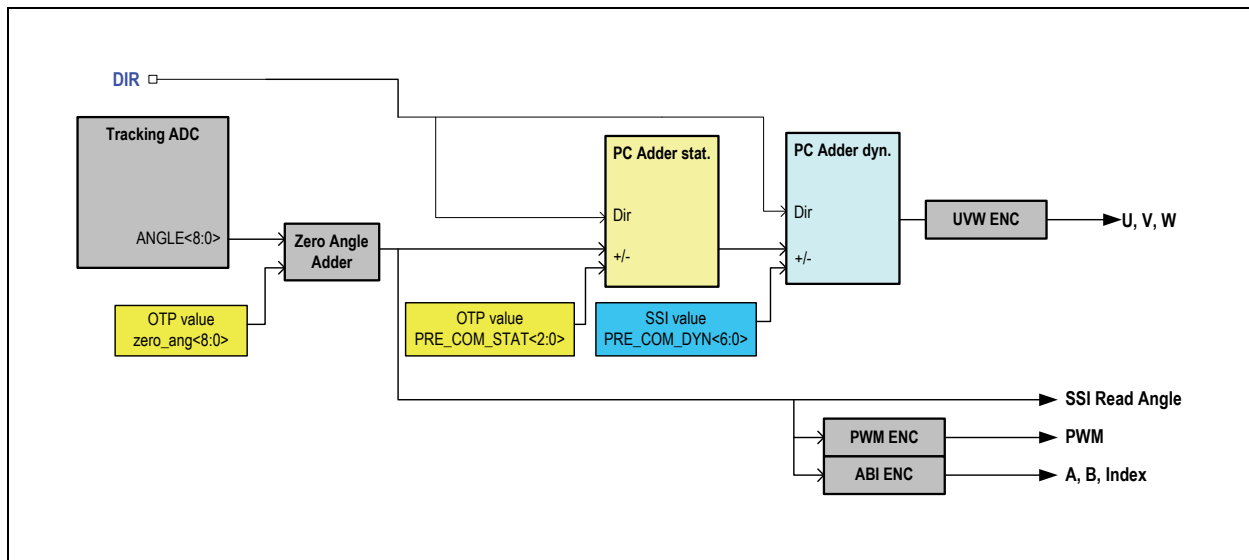

**Note(s):**

1. The dynamic pre-commutation is set to zero always if the direction is changed over the pin **DIR**. A new value **PRE\_COM\_DYN** must be written again. The static pre-commutation is always enabled and will shift the output.

### Commutation Output UVW

The pre-commutation function is used only at the U,V,W output. Figure 36 shows the transition on the outputs U,V,W in case of a two pole pair configuration. The static pre-commutation value was set to 12 degrees.

**Figure 36:**  
UVW Output Transitions with Pre-Commutation

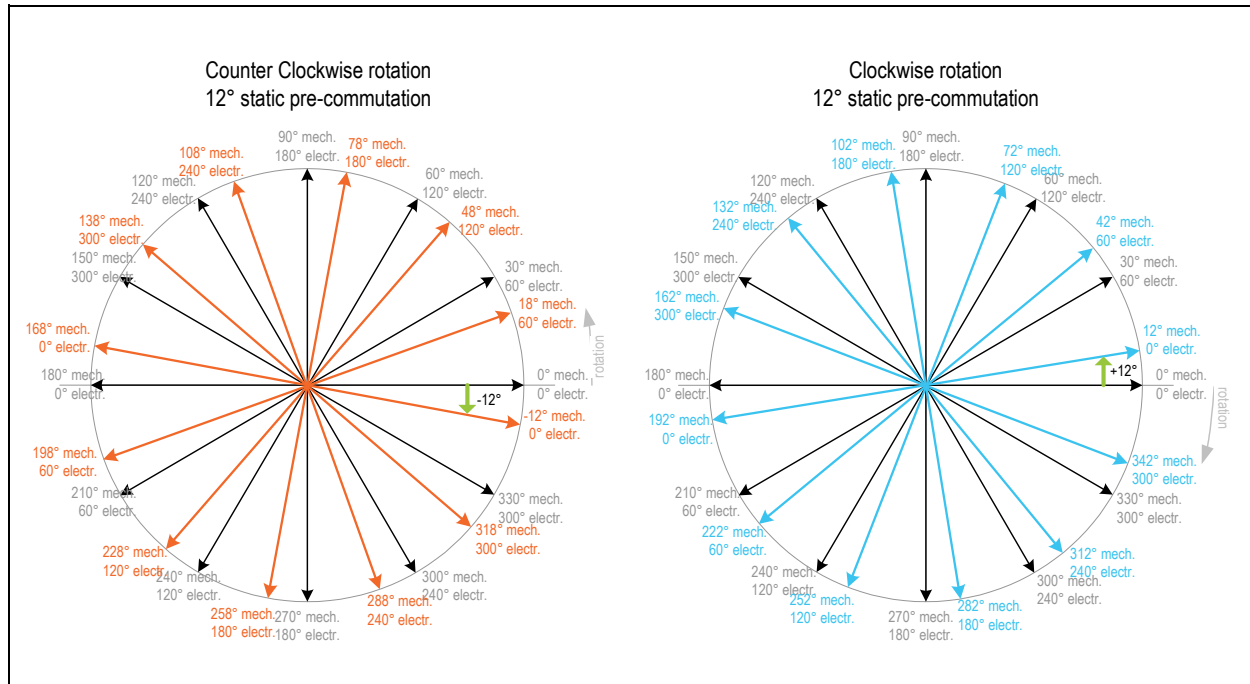

**Figure 37:**  
**Dynamic and Static Pre-Commutation**

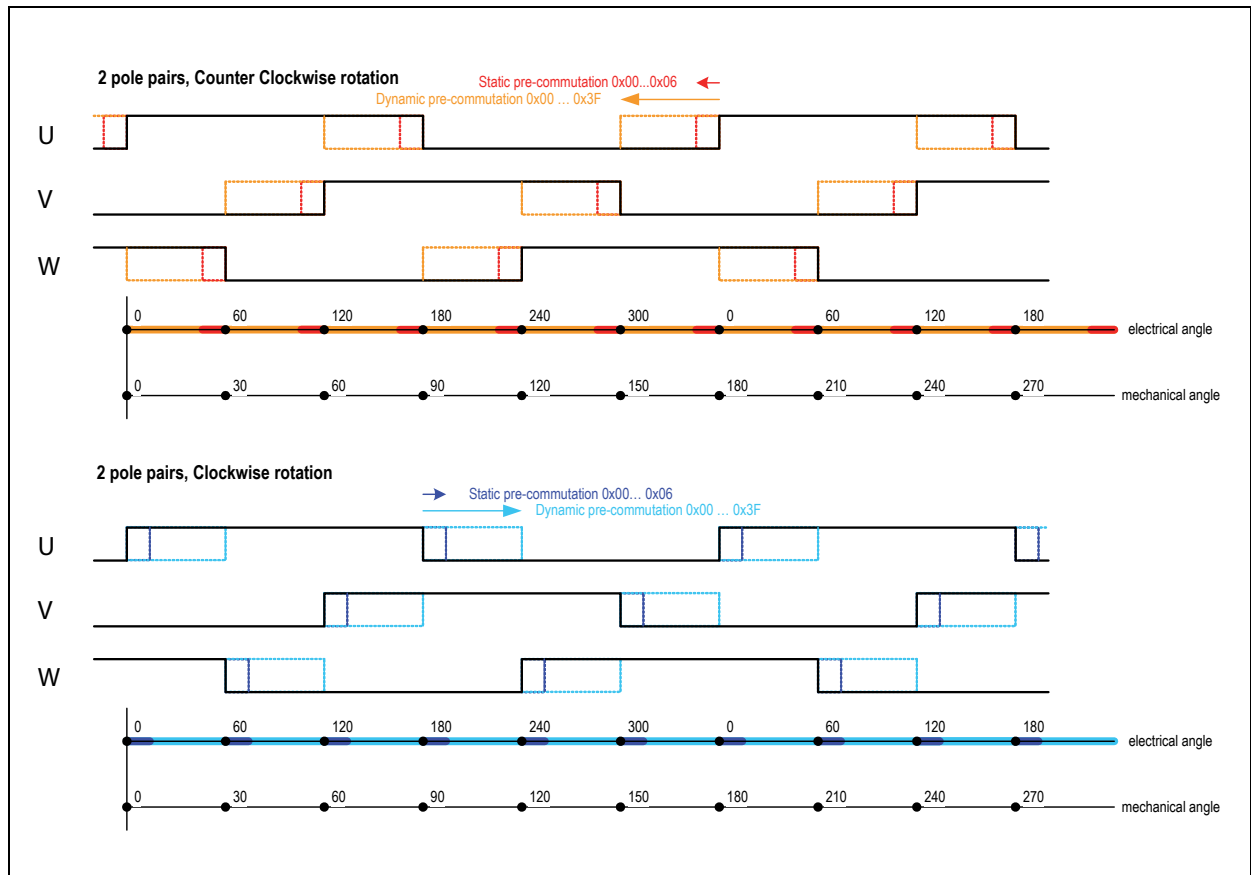

### Hysteresis of the Incremental Outputs

A hysteresis is implemented to get a stable output value at the SSI command and to reduce jitter at the PWM and UVW outputs. At start up the hysteresis counter is at 0, the range is  $\pm 1$  LSB. The hysteresis can be deactivated by setting OTP bit **Hyst\_dis**.

**Figure 38:**  
Hysteresis of the Outputs

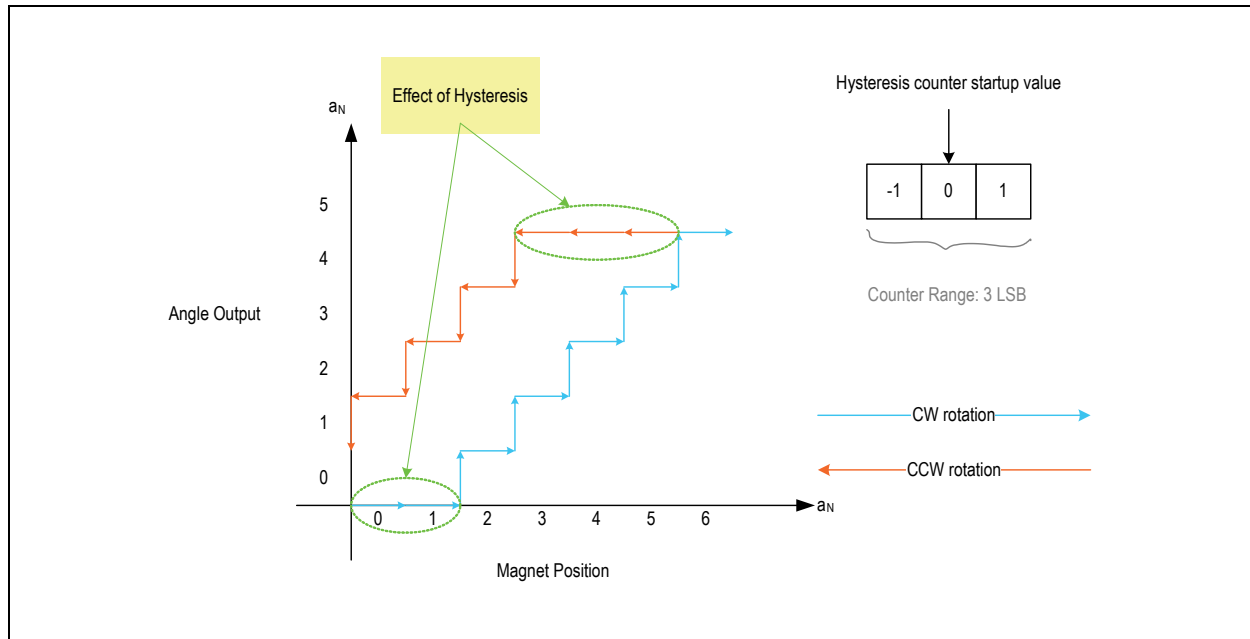

### Multi Turn Counter

A 9-bit register is used for counting the magnet's revolutions. With each zero transition in any direction, the output of a special counter is incremented or decremented. The initial value after reset is 0 LSB. Clockwise rotation gives increasing angle values and positive turn count. Counter clockwise rotation exhibits decreasing angle values and a negative turn count respectively.

The counter output can be reset by using command 20 – SET MT Counter. It is immediately reset by the rising clock edge of this bit. Any zero crossing between the clock edge and the next counter readout changes the counter value.

### High Speed Operation

The AS5132 is using a fast tracking ADC (TADC) to determine the angle of the magnet. The TADC is tracking the angle of the magnet with cycle time of  $2\mu\text{s}$  (typ. 1.4). Once the TADC is synchronized with the angle, it sets the LOCK bit in the status register. Once it is locked, it requires only one cycle [ $2\mu\text{s}$  (typ. 1.4)] to track the moving magnet. The AS5132 can operate in locked mode at rotational speeds up to max. 72,900 rpm.

### ***Propagation Delay***

The propagation delay is the time required from reading the magnetic field by the Hall sensors to calculating the angle and making it available on the serial or PWM interface. While the propagation delay is usually negligible on low speeds, it is an important parameter at high speeds. The longer the propagation delay, the larger becomes the angle error for a rotating magnet as the magnet is moving while the angle is calculated. The position error increases linearly with speed.

### ***Error Detection***

The following errors are detected by the system:

- Lock bit → The TADC has not yet found a valid angular position
- AGC alarm → The AGC <5:1> value is “1 1111 binary”. Magnetic field is too weak.

By default, Lock bit error should activate the error condition at the outputs. The AGC alarm is permanently available at the DIAG pin.

Error condition at commutation and incremental outputs:

- U, V and W outputs all ‘0’
- A, B and I outputs all ‘1’

## Application Information

### Physical Placement of the Magnet

The best linearity can be achieved by placing the center of the magnet exactly over the defined center of the IC package as shown in Figure 39.

**Figure 39:**  
Defined IC Center and Magnet Displacement Radius

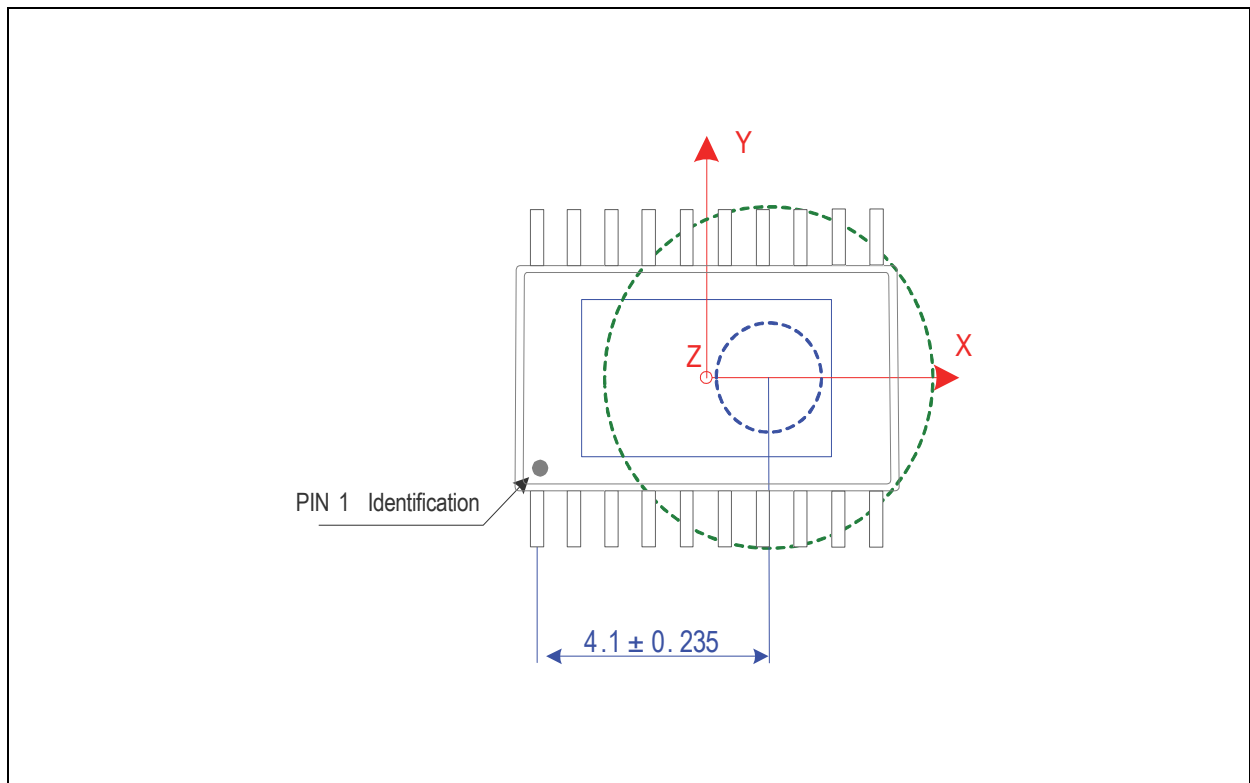

The centre of the Hall sensor array is shifted by a constant value in x axis indicated by the blue circle. In the application it is important to refer to this point.

**Figure 40:**  
Vertical Cross Section of SSOP-20

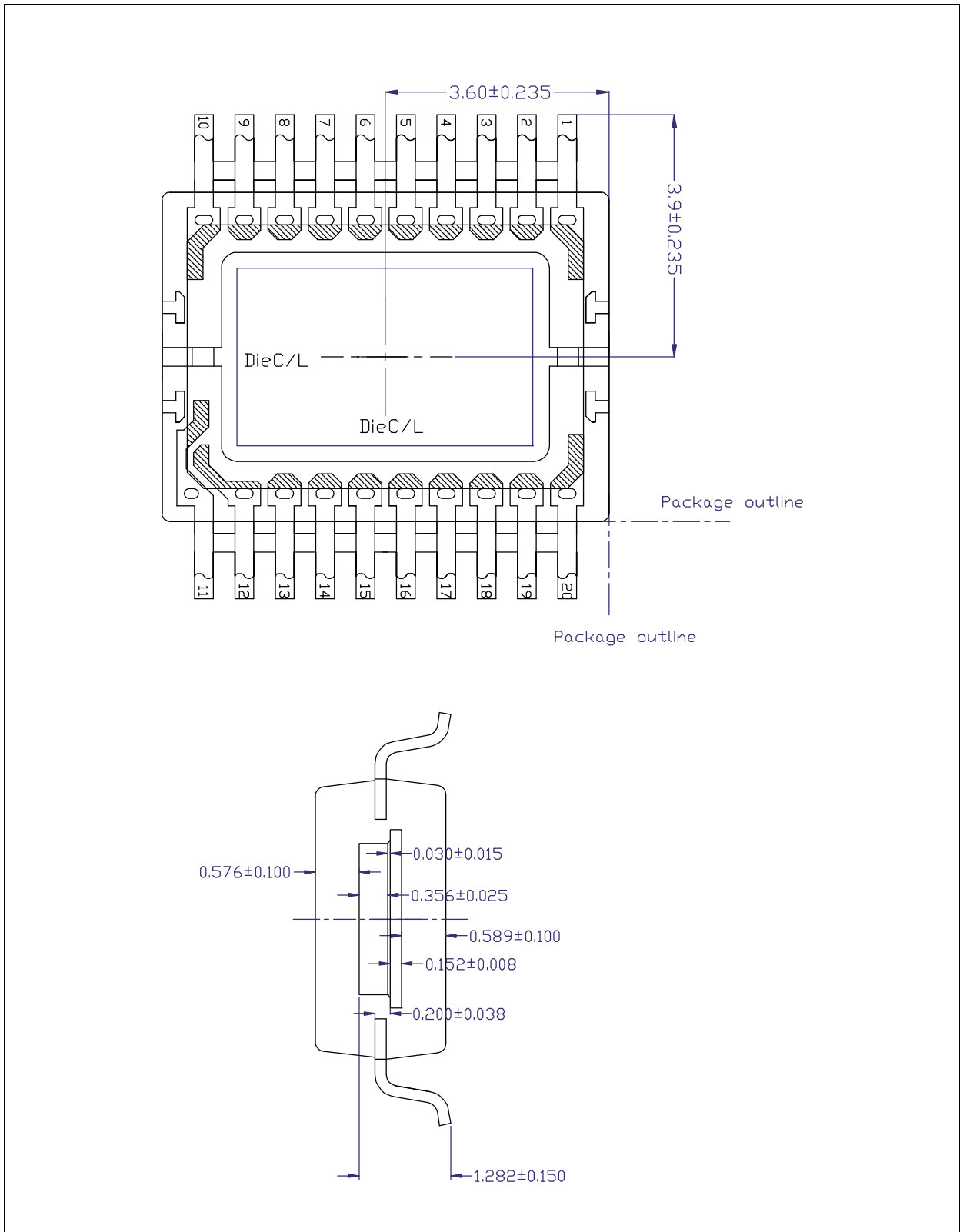

**Note(s):**

1. All dimensions in mm.
2. Die is slightly off centered.



### Package Drawings & Markings

The device is available in a 20-Lead Shrink Small Outline package.

**Figure 41:**  
Package Drawings and Dimensions

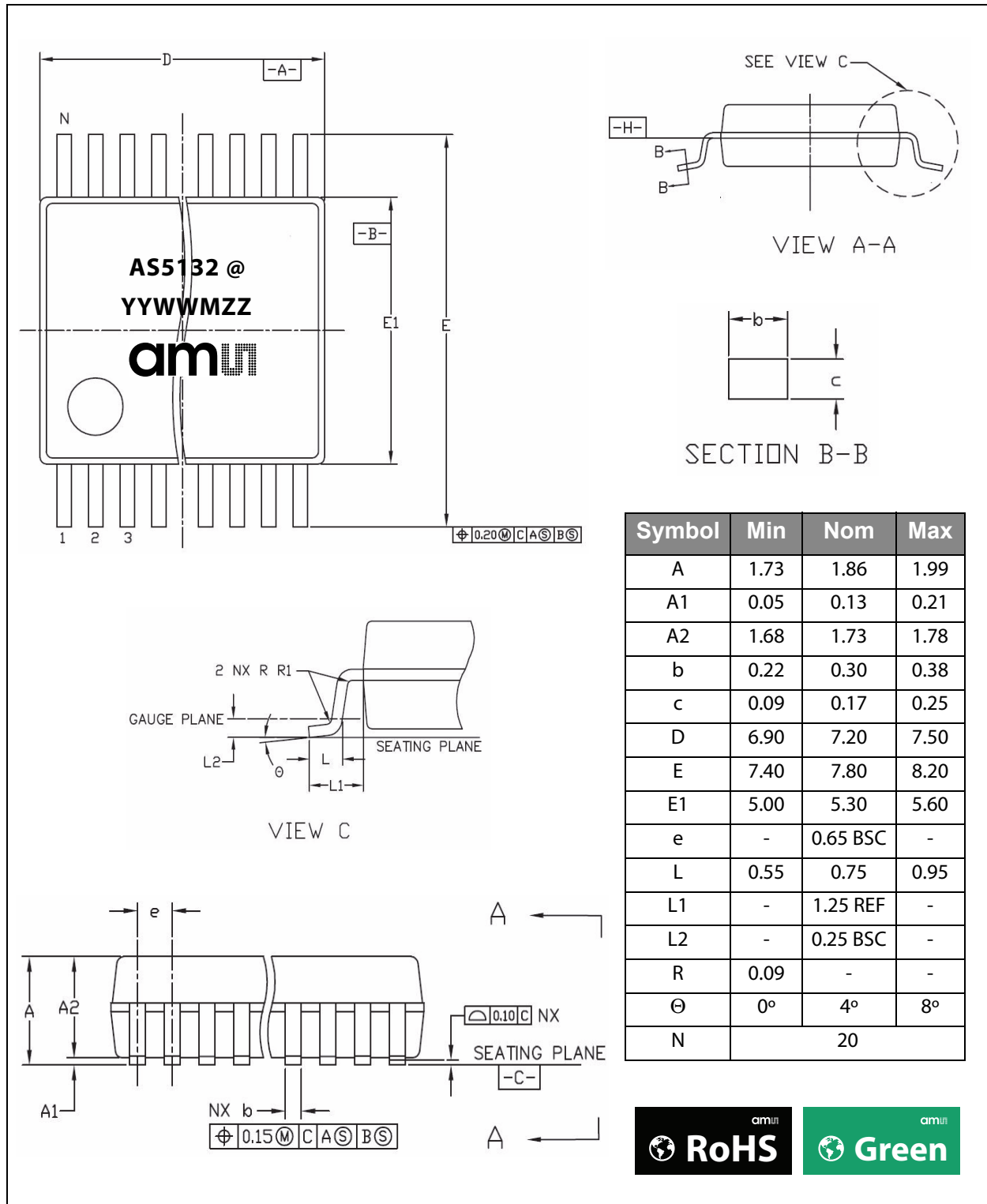

**Note(s):**

1. Dimensions and tolerancing conform to ASME Y14.5M-1994.
2. All dimensions are in millimeters. Angles are in degrees.

**Figure 42:**  
Marking: @YYWMZZ

@	YY	WW	M	ZZ
Sublot identifier	Last two digits of the manufacturing year	Manufacturing week	Plant identifier	Assembly traceability code

**Recommended PCB Footprint**

**Figure 43:**  
PCB Footprint

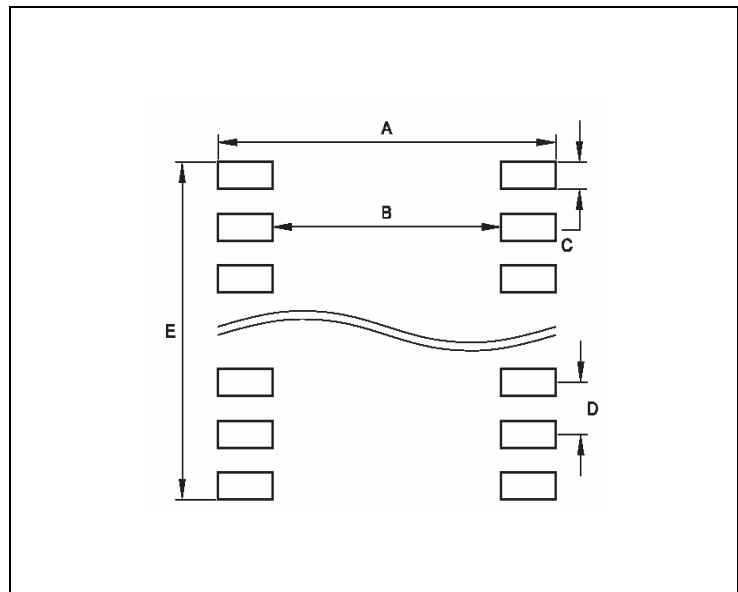

Recommended Footprint Data		
Symbol	mm	inch
A	9.02	0.355
B	6.16	0.242
C	0.46	0.018
D	0.65	0.025
E	6.31	0.248

**Ordering & Contact Information**

The devices are available as the standard products shown in Figure 44.

**Figure 44:**  
**Ordering Information**

Ordering Code	Package	Marking	Delivery Form	Delivery Quantity
AS5132-HSST	SSOP-20	AS5132	13" Tape & Reel in dry pack	2000
AS5132-HSSM	SSOP-20	AS5132	7" Tape & Reel in dry pack	500

Buy our products or get free samples online at:

[www.ams.com/ICdirect](http://www.ams.com/ICdirect)

Technical Support is available at:

[www.ams.com/Technical-Support](http://www.ams.com/Technical-Support)

Provide feedback about this document at:

[www.ams.com/Document-Feedback](http://www.ams.com/Document-Feedback)

For further information and requests, e-mail us at:

[ams\\_sales@ams.com](mailto:ams_sales@ams.com)

For sales offices, distributors and representatives, please visit:

[www.ams.com/contact](http://www.ams.com/contact)

**Headquarters**

ams AG  
Tobelbaderstrasse 30  
8141 Premstaetten  
Austria, Europe

Tel: +43 (0) 3136 500 0

Website: [www.ams.com](http://www.ams.com)

## RoHS Compliant & ams Green Statement

**RoHS:** The term RoHS compliant means that ams AG products fully comply with current RoHS directives. Our semiconductor products do not contain any chemicals for all 6 substance categories, including the requirement that lead not exceed 0.1% by weight in homogeneous materials. Where designed to be soldered at high temperatures, RoHS compliant products are suitable for use in specified lead-free processes.

**ams Green (RoHS compliant and no Sb/Br):** ams Green defines that in addition to RoHS compliance, our products are free of Bromine (Br) and Antimony (Sb) based flame retardants (Br or Sb do not exceed 0.1% by weight in homogeneous material).

**Important Information:** The information provided in this statement represents ams AG knowledge and belief as of the date that it is provided. ams AG bases its knowledge and belief on information provided by third parties, and makes no representation or warranty as to the accuracy of such information. Efforts are underway to better integrate information from third parties. ams AG has taken and continues to take reasonable steps to provide representative and accurate information but may not have conducted destructive testing or chemical analysis on incoming materials and chemicals. ams AG and ams AG suppliers consider certain information to be proprietary, and thus CAS numbers and other limited information may not be available for release.

## Copyrights & Disclaimer

Copyright ams AG, Tobelbader Strasse 30, 8141 Premstaetten, Austria-Europe. Trademarks Registered. All rights reserved. The material herein may not be reproduced, adapted, merged, translated, stored, or used without the prior written consent of the copyright owner.

Devices sold by ams AG are covered by the warranty and patent indemnification provisions appearing in its General Terms of Trade. ams AG makes no warranty, express, statutory, implied, or by description regarding the information set forth herein. ams AG reserves the right to change specifications and prices at any time and without notice. Therefore, prior to designing this product into a system, it is necessary to check with ams AG for current information. This product is intended for use in commercial applications. Applications requiring extended temperature range, unusual environmental requirements, or high reliability applications, such as military, medical life-support or life-sustaining equipment are specifically not recommended without additional processing by ams AG for each application. This product is provided by ams AG "AS IS" and any express or implied warranties, including, but not limited to the implied warranties of merchantability and fitness for a particular purpose are disclaimed.

ams AG shall not be liable to recipient or any third party for any damages, including but not limited to personal injury, property damage, loss of profits, loss of use, interruption of business or indirect, special, incidental or consequential damages, of any kind, in connection with or arising out of the furnishing, performance or use of the technical data herein. No obligation or liability to recipient or any third party shall arise or flow out of ams AG rendering of technical or other services.

## Document Status

Document Status	Product Status	Definition
Product Preview	Pre-Development	Information in this datasheet is based on product ideas in the planning phase of development. All specifications are design goals without any warranty and are subject to change without notice
Preliminary Datasheet	Pre-Production	Information in this datasheet is based on products in the design, validation or qualification phase of development. The performance and parameters shown in this document are preliminary without any warranty and are subject to change without notice
Datasheet	Production	Information in this datasheet is based on products in ramp-up to full production or full production which conform to specifications in accordance with the terms of ams AG standard warranty as given in the General Terms of Trade
Datasheet (discontinued)	Discontinued	Information in this datasheet is based on products which conform to specifications in accordance with the terms of ams AG standard warranty as given in the General Terms of Trade, but these products have been superseded and should not be used for new designs

## Revision Information

Changes from 2-04 (2014-Sep-05) to current revision 2-06 (2016-Jan-26)	Page
<b>2-04 (2014-Sep-05) to 2-05 (2016-Jan-22)</b>	
Updated text under General Description section	1
Updated Figure 1	1
Updated Figure 4	4
Updated Figure 14	12
Updated text under Figure 17	13
Updated Figure 18	15
Updated Programming Verification section	19
Updated Figure 27	21
<b>2-05 (2016-Jan-22) to 2-06 (2016-Jan-26)</b>	
Updated Figure 4	4
Updated Figure 14	12
Updated Figure 27	21

**Note(s):**

1. Page and figure numbers for the previous version may differ from page and figure numbers in the current revision.
2. Correction of typographical errors is not explicitly mentioned.

## Content Guide

<b>1</b>	<b>General Description</b>
1	Key Benefits & Features
2	Applications
3	Block Diagram
<b>4</b>	<b>Pin Assignment</b>
<b>6</b>	<b>Absolute Maximum Ratings</b>
<b>7</b>	<b>Electrical Characteristics</b>
7	Operating Conditions
7	System Parameters
8	Magnet Specifications
8	Programming Parameters
8	DC Characteristics of Digital Inputs
9	DC Characteristics of Digital Outputs
9	Timing Characteristics
<b>11</b>	<b>Detailed Description</b>
12	Synchronous Serial Interface (SSI)
13	Commands of the SSI in Normal Mode
15	Extended Synchronous Serial Interface Mode
19	Programming Verification
21	Pulse Width Modulation (PWM) Output
21	PWM External Clock
23	Incremental Outputs
24	Quadrature A/B Output
25	Step Output Mode
26	Pre-Commutation Function
27	Commutation Output UVW
29	Hysteresis of the Incremental Outputs
29	Multi Turn Counter
29	High Speed Operation
30	Propagation Delay
30	Error Detection
<b>31</b>	<b>Application Information</b>
31	Physical Placement of the Magnet
<b>33</b>	<b>Package Drawings &amp; Markings</b>
34	Recommended PCB Footprint
<b>35</b>	<b>Ordering &amp; Contact Information</b>
<b>36</b>	<b>RoHS Compliant &amp; ams Green Statement</b>
<b>37</b>	<b>Copyrights &amp; Disclaimer</b>
<b>38</b>	<b>Document Status</b>
<b>39</b>	<b>Revision Information</b>