

FEATURES

Integrated photodiode + TIA
Differential responsivity: 5.5 mV/μW
50 μm diameter germanium photodiode
Input sensitivity: -19.5 dBm @ 6.144 Gbps
Wavelength range: 830 nm to 1560 nm
Single 3.3 V supply
Power dissipation: 65 mW
Differential output swing: 240 mV p-p
On-chip power monitor function
Die size: 0.835 mm × 0.675 mm

APPLICATIONS

Optical receivers up to 6.5 Gbps
6G CPRI, OBSAI, and 8G short range and LTE receivers
Receiver optical subassemblies (ROSA)

GENERAL DESCRIPTION

The ADN3000-06 is a complete high speed optical receiver featuring a proprietary large-area germanium PIN photodiode integrated with a transimpedance amplifier (TIA). The integration of the photodiode eliminates bond wires between the diode and TIA that provides guaranteed performance and improved manufacturing reliability. The ADN3000-06 supports data rates of up to 6.5 Gbps for telecommunication and point-to-point LAN applications, and a wide range of operating wavelengths from 830 nm to 1560 nm.

FUNCTIONAL BLOCK DIAGRAM

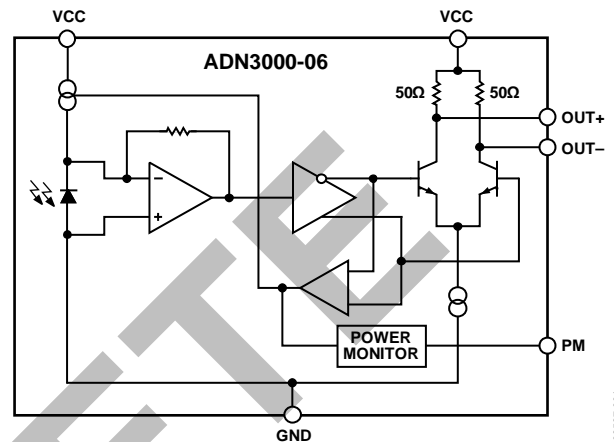

Figure 1.

The ADN3000-06 also features an optical average power monitoring circuit that generates a voltage output proportional to the average photodiode current.

Typical power consumption of ADN3000-06 is 65 mW from a single 3.3 V supply. In saturated output, the signal has a typical differential amplitude of 240 mV p-p.

The ADN3000-06 is available in die form, and it is operational over the extended industrial temperature range of -40°C to +85°C.

Rev. Sp0

Information furnished by Analog Devices is believed to be accurate and reliable. However, no responsibility is assumed by Analog Devices for its use, nor for any infringements of patents or other rights of third parties that may result from its use. Specifications subject to change without notice. No license is granted by implication or otherwise under any patent or patent rights of Analog Devices. Trademarks and registered trademarks are the property of their respective owners.

NOTES

OBSOLETE