

FEATURES

High performance, triaxial digital output accelerometer
 $\pm 14.2\text{ g}$ full-scale range at 16-bit resolution (0.434 mg/LSB)
2 kHz output sample rate with optional data FIFOs
Programmable filter response
20 Hz, 46 Hz, 92 Hz, 184 Hz
Continuous electromechanical self-test
Additional key-on and on demand self-test routines
Temperature compensated, high precision zero-g bias and sensitivity performance
X-/Y-/Z-axis offset adjust
Low quiescent current draw
High linearity performance
 -40°C to $+105^{\circ}\text{C}$ temperature range
Qualified for automotive applications

APPLICATIONS

Vehicle dynamic control (VDC)
Electronic stability program (ESP)
Electronic chassis control
Platform stabilization/leveling

GENERAL DESCRIPTION

The **ADXL700** device is a high precision, triaxial accelerometer designed for electronic stability control and other high performance applications. A built in temperature compensation routine ensures sensitivity stability to better than $\pm 3\%$ across the entire temperature range. The **ADXL700** is designed with selectable -3 dB filter corner frequencies to satisfy a range of applications, and the 2 kHz output data rate allows sufficient oversampling of the acceleration information.

The acceleration data output from the device is a true 16-bit word and is contained in a 32-bit SPI transaction. The SPI interface contains additional fault detection bits and data formatting bits designed to assist high reliability applications. SPI communications are compatible up to 8 MHz. The 16-bit acceleration data-word offers a resolution of 0.434 mg/LSB for the $\pm 14.2\text{ g}$ full-scale range of the device.

The **ADXL700** is available in an SOIC package with an inverted paddle for improved EMI/RFI robustness. The **ADXL700** operates at both 3.3 V and 5 V, and is specified to operate across the full automotive temperature range of -40°C to $+105^{\circ}\text{C}$.

FUNCTIONAL BLOCK DIAGRAM

Figure 1.

For more information about the **ADXL700**, please contact the Analog Devices, Inc., *Customer Interaction Center* at http://www.analog.com/en/content/technical_support_page/fca.html to connect with a technical support specialist.

Rev. Sp0

Document Feedback

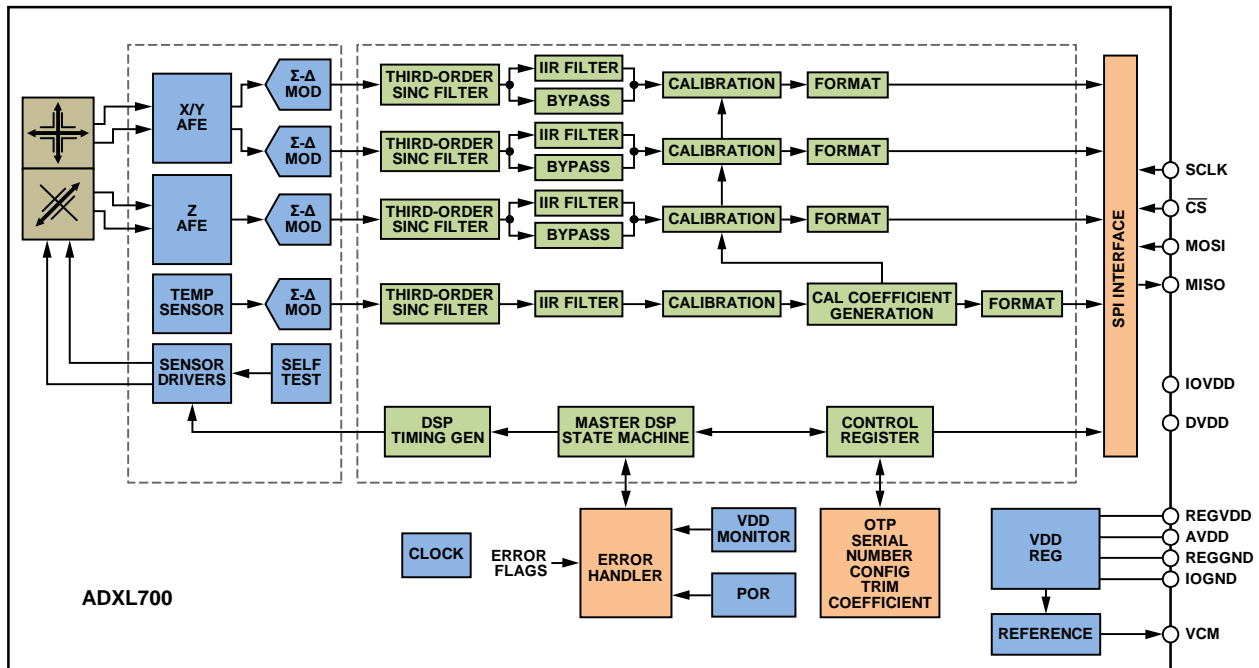
Information furnished by Analog Devices is believed to be accurate and reliable. However, no responsibility is assumed by Analog Devices for its use, nor for any infringements of patents or other rights of third parties that may result from its use. Specifications subject to change without notice. No license is granted by implication or otherwise under any patent or patent rights of Analog Devices. Trademarks and registered trademarks are the property of their respective owners.

One Technology Way, P.O. Box 9106, Norwood, MA 02062-9106, U.S.A.
 Tel: 781.329.4700 ©2015 Analog Devices, Inc. All rights reserved.
Technical Support www.analog.com

ADXL700* PRODUCT PAGE QUICK LINKS

Last Content Update: 02/23/2017

COMPARABLE PARTS

View a parametric search of comparable parts.

DOCUMENTATION

Data Sheet

- ADXL700: High Precision, Low-g, Digital Triaxial Accelerometer Data Sheet

DESIGN RESOURCES

- adxl700 Material Declaration
- PCN-PDN Information
- Quality And Reliability
- Symbols and Footprints

DISCUSSIONS

View all adxl700 EngineerZone Discussions.

SAMPLE AND BUY

Visit the product page to see pricing options.

TECHNICAL SUPPORT

Submit a technical question or find your regional support number.

DOCUMENT FEEDBACK

Submit feedback for this data sheet.

NOTES