

## GaAs PIN MMIC VOLTAGE-VARIABLE ATTENUATOR, 36 - 50 GHz

### Typical Applications

This HMC-VVD106 is ideal for:

- Short Haul / High Capacity Radios
- Automotive Radar
- Test Equipment
- SATCOM
- Military
- Point-to-Point Radios
- Point to Multi-Point Radios

### Features

- Low Insertion Loss: 1.5 dB
- Wide Dynamic Range: 22 dB
- Balanced Topology
- High Input IP3: +17 dBm
- Analog Control Voltage: 0 to +4V
- Die Size: 1.47 x 1.5 x 0.1 mm

### Functional Diagram

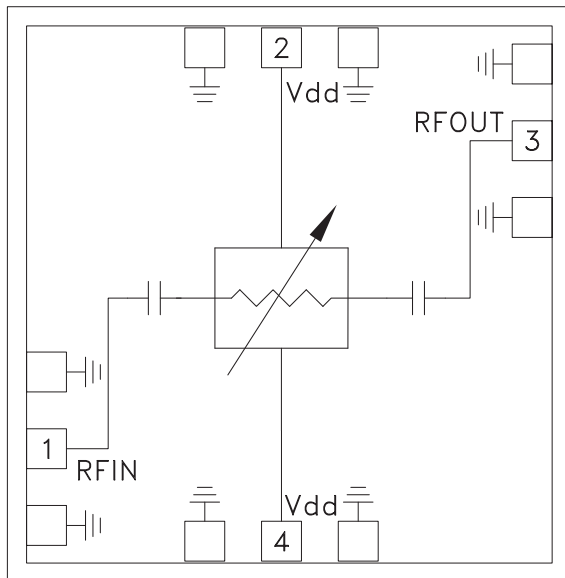

### General Description

The HMC-VVD106 is a monolithic GaAs PIN diode based Voltage Variable Attenuator (VVA) which exhibits low insertion loss, high IP3, and wide dynamic range. The balanced topology delivers excellent return loss while the single control voltage can be applied to either side of the die. All bond pads and the die backside are Ti/Au metallized, and the PIN diode devices are fully passivated for reliable operation. This wideband VVA MMIC is compatible with conventional die attach methods, as well as thermocompression and thermosonic wirebonding, making it ideal for MCM and hybrid microcircuit applications. All data shown herein is measured on chip in a 50 Ohm environment and contacted with RF probes.

### Electrical Specifications, $T_A = +25^\circ\text{C}$ , 50 Ohm System

Parameter	Min.	Typ.	Max.	Units
Frequency Range		36 - 50		GHz
Insertion Loss		1.5	2	dB
Attenuation Range		21		dB
Return Loss		15		dB
IM3 @ Pin = 0 dBm / Tone	30			dBc

\*Unless otherwise indicated, all measurements are from probed die

# HMC-VVD106\* PRODUCT PAGE QUICK LINKS

Last Content Update: 02/23/2017

---

## COMPARABLE PARTS

View a parametric search of comparable parts.

## DOCUMENTATION

### Data Sheet

- HMC-VVD106 Data Sheet

## TOOLS AND SIMULATIONS

- HMC-VVD106 S-Parameter

## REFERENCE MATERIALS

### Technical Articles

- 38, 60 & 82 GHz MMICs for High Capacity Communication Links

## DESIGN RESOURCES

- HMC-VVD106 Material Declaration
- PCN-PDN Information
- Quality And Reliability
- Symbols and Footprints

## DISCUSSIONS

View all HMC-VVD106 EngineerZone Discussions.

## SAMPLE AND BUY

Visit the product page to see pricing options.

## TECHNICAL SUPPORT

Submit a technical question or find your regional support number.

## DOCUMENT FEEDBACK

Submit feedback for this data sheet.

---

**GaAs PIN MMIC VOLTAGE-VARIABLE  
ATTENUATOR, 36 - 50 GHz**

**Minimum Attenuation vs. Frequency**

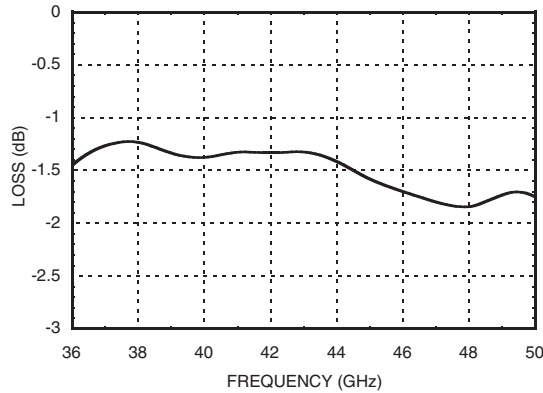

**Maximum Attenuation vs. Frequency**

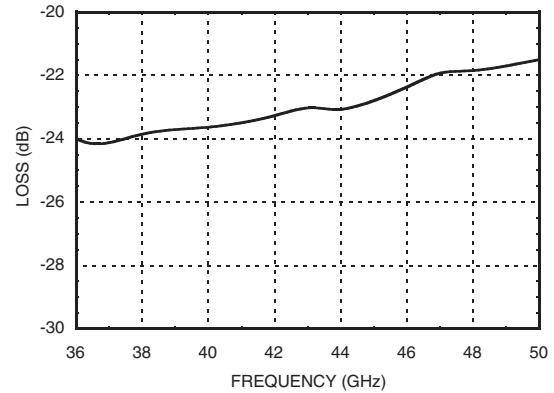

**Return Loss vs. Frequency @ Minimum Attenuation**

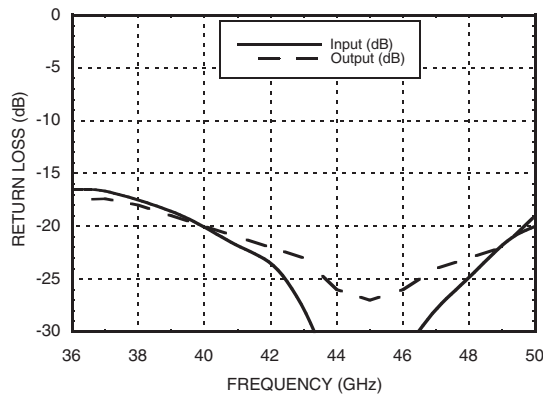

**Return Loss vs. Frequency @ Maximum Attenuation**

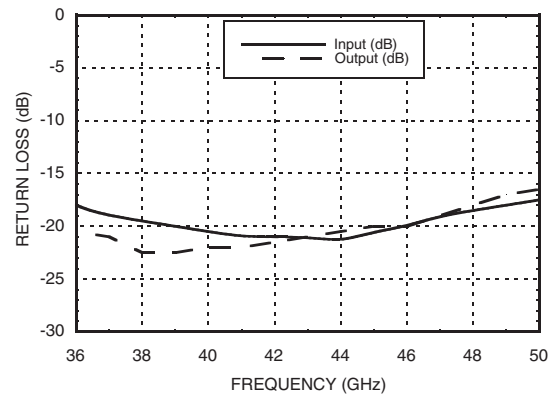

**IM3 vs. Vdd @ 38.5 GHz**

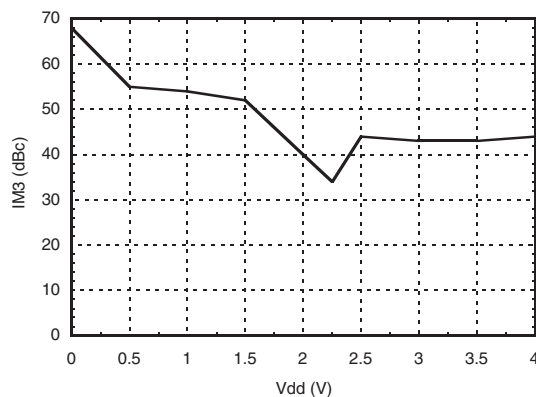

Information furnished by Analog Devices is believed to be accurate and reliable. However, no responsibility is assumed by Analog Devices for its use, nor for any infringements of patents or other rights of third parties that may result from its use. Specifications subject to change without notice. No license is granted by implication or otherwise under any patent or patent rights of Analog Devices. Trademarks and registered trademarks are the property of their respective owners.

For price, delivery, and to place orders: Analog Devices, Inc., One Technology Way, P.O. Box 9106, Norwood, MA 02062-9106 Phone: 781-329-4700 • Order online at [www.analog.com](http://www.analog.com) Application Support: Phone: 1-800-ANALOG-D

## GaAs PIN MMIC VOLTAGE-VARIABLE ATTENUATOR, 36 - 50 GHz

### Absolute Maximum Ratings

Control Voltage Range (Vdd)	-6V to +6V Vdc
Storage Temperature	-65 to +150 °C
Operating Temperature	-55 to +85 °C
Bias Current (Idd)	20 mA



ELECTROSTATIC SENSITIVE DEVICE  
OBSERVE HANDLING PRECAUTIONS

### Outline Drawing

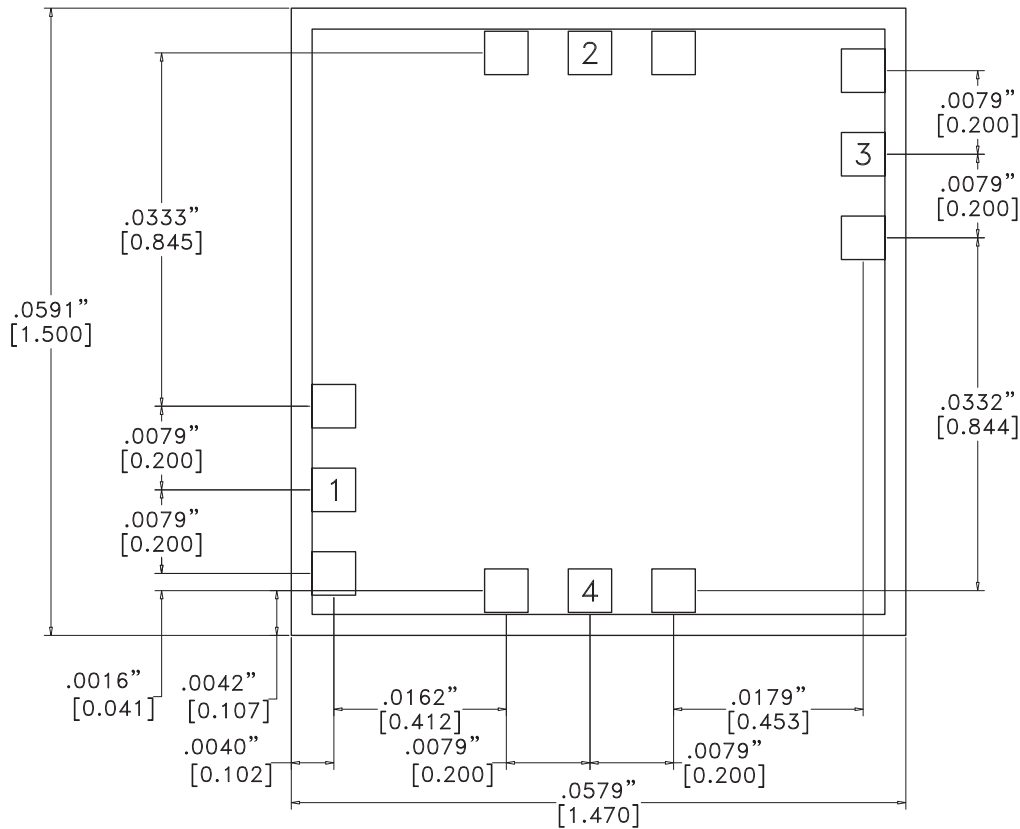

### Die Packaging Information [1]

Standard	Alternate
GP-2 (Gel Pack)	[2]



[1] Refer to the "Packaging Information" section for die packaging dimensions.

[2] For alternate packaging information contact Hittite Microwave Corporation.

#### NOTES:

1. ALL DIMENSIONS ARE IN INCHES [MM].
2. TYPICAL BOND PAD IS .004" SQUARE.
3. BACKSIDE METALLIZATION: GOLD.
4. BACKSIDE METAL IS GROUND.
5. BOND PAD METALLIZATION: GOLD.
6. CONNECTION NOT REQUIRED FOR UNLABELED BOND PADS.
7. OVERALL DIE SIZE ±.002"

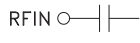
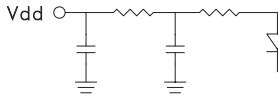
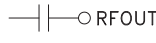
**GaAs PIN MMIC VOLTAGE-VARIABLE  
ATTENUATOR, 36 - 50 GHz**
**Pad Descriptions**

Pad Number	Function	Pad Description	Interface Schematic
1	RFIN	This pin is DC blocked and matched to 50 Ohms.	
2, 4	Vdd	Control Input.	
3	RFOUT	This pin is DC blocked and matched to 50 Ohms.	
Die Bottom	GND	Die bottom must be connected to RF/DC ground.	

**GaAs PIN MMIC VOLTAGE-VARIABLE  
ATTENUATOR, 36 - 50 GHz**

**Assembly Diagram**

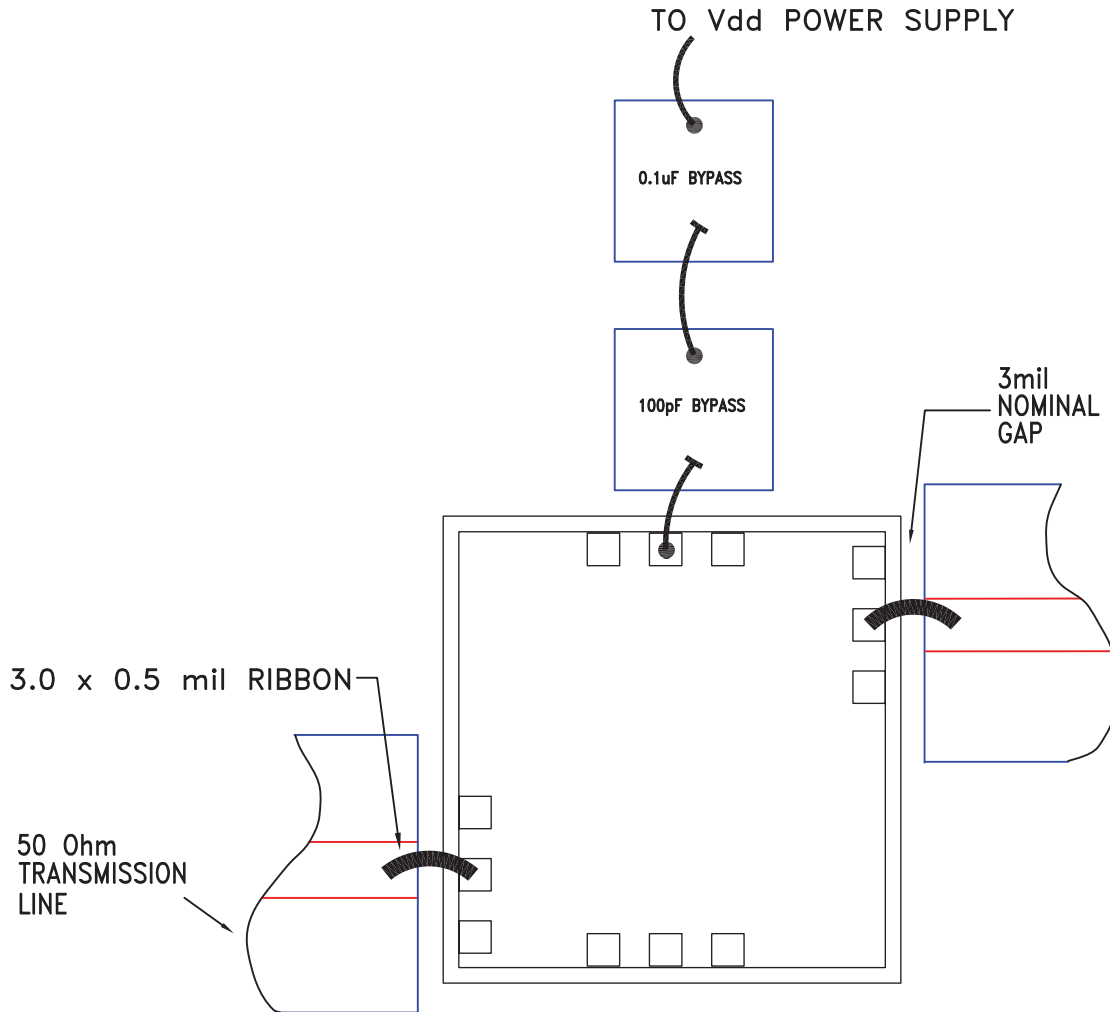

Note 1: Bypass caps should be 100 pF (approximately) ceramic (single-layer) placed no farther than 30 mils from the attenuator.

Note 2: Best performance obtained from use of <10 mil (long) by 1.5 by 0.5mil ribbons on input and output.

Note 3: Part can be biased from either side.

## GaAs PIN MMIC VOLTAGE-VARIABLE ATTENUATOR, 36 - 50 GHz

### Mounting & Bonding Techniques for Millimeterwave GaAs MMICs

The die should be attached directly to the ground plane eutectically or with conductive epoxy (see HMC general Handling, Mounting, Bonding Note).

50 Ohm Microstrip transmission lines on 0.127mm (5 mil) thick alumina thin film substrates are recommended for bringing RF to and from the chip (Figure 1). If 0.254mm (10 mil) thick alumina thin film substrates must be used, the die should be raised 0.150mm (6 mils) so that the surface of the die is coplanar with the surface of the substrate. One way to accomplish this is to attach the 0.102mm (4 mil) thick die to a 0.150mm (6 mil) thick molybdenum heat spreader (moly-tab) which is then attached to the ground plane (Figure 2).

Microstrip substrates should be placed as close to the die as possible in order to minimize bond wire length. Typical die-to-substrate spacing is 0.076mm to 0.152 mm (3 to 6 mils).

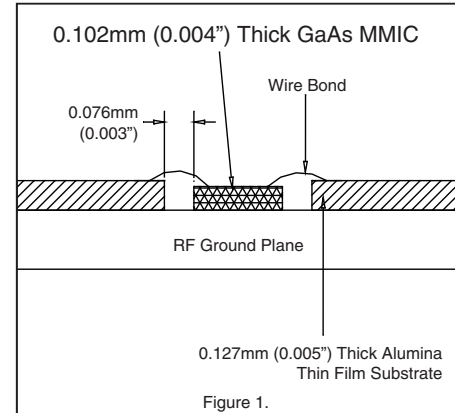

### Handling Precautions

Follow these precautions to avoid permanent damage.

**Storage:** All bare die are placed in either Waffle or Gel based ESD protective containers, and then sealed in an ESD protective bag for shipment. Once the sealed ESD protective bag has been opened, all die should be stored in a dry nitrogen environment.

**Cleanliness:** Handle the chips in a clean environment. DO NOT attempt to clean the chip using liquid cleaning systems.

**Static Sensitivity:** Follow ESD precautions to protect against ESD strikes.

**Transients:** Suppress instrument and bias supply transients while bias is applied. Use shielded signal and bias cables to minimize inductive pick-up.

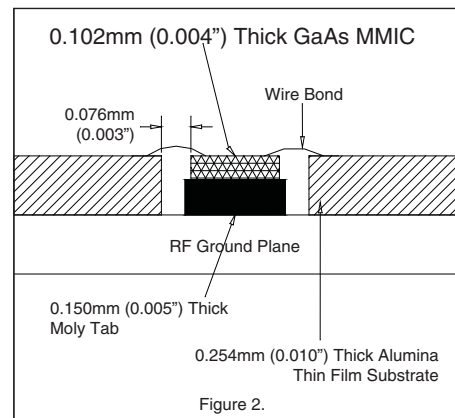

**General Handling:** Handle the chip along the edges with a vacuum collet or with a sharp pair of bent tweezers. The surface of the chip has fragile air bridges and should not be touched with vacuum collet, tweezers, or fingers.

### Mounting

The chip is back-metallized and can be die mounted with AuSn eutectic preforms or with electrically conductive epoxy. The mounting surface should be clean and flat.

**Eutectic Die Attach:** A 80/20 gold tin preform is recommended with a work surface temperature of 255 °C and a tool temperature of 265 °C. When hot 90/10 nitrogen/hydrogen gas is applied, tool tip temperature should be 290 °C. DO NOT expose the chip to a temperature greater than 320 °C for more than 20 seconds. No more than 3 seconds of scrubbing should be required for attachment.

**Epoxy Die Attach:** Apply a minimum amount of epoxy to the mounting surface so that a thin epoxy fillet is observed around the perimeter of the chip once it is placed into position. Cure epoxy per the manufacturer's schedule.

### Wire Bonding

RF bonds made with 0.003" x 0.0005" ribbon are recommended. These bonds should be thermosonically bonded with a force of 40-60 grams. DC bonds of 0.001" (0.025 mm) diameter, thermosonically bonded, are recommended. Ball bonds should be made with a force of 40-50 grams and wedge bonds at 18-22 grams. All bonds should be made with a nominal stage temperature of 150 °C. A minimum amount of ultrasonic energy should be applied to achieve reliable bonds. All bonds should be as short as possible, less than 12 mils (0.31 mm).