

② TOLERANCE

Length(meter)	Max-M	Mix-M
0.3	0.03	0.025
0.5	0.03	0.025
1	0.04	0.035
2	0.06	0.06
3	0.09	0.09
5	0.15	0.15
7	0.21	0.21
10	0.3	0.3
15	0.45	0.45
20	0.6	0.6
30	0.9	0.9

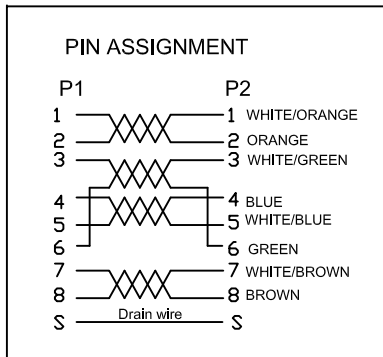

Order Code:

① A-MCSP-80XXX : color Grey

④② Order lengths in meter: 0.3,0.5,1,2,3,5,7,10,15,20,30

A-MCSP-80XXX/X

④② Order lengths in meter: 0.3,0.5,1,2,3,5,7,10,15,20,30 Order color:(R)Red,(Y)Yellow (G)Green,(B)Blue

Electrical
100% short,open,miswire test

3	mold	PVC,50P	9.0	G
2	plug	8P8C plating gold 3U" with metal shield	2	PCS
1	cable	FTP (26AWG*1P)*4+D+A+PVC, OD:5.2±0.2mm CAT5E	2.0	M
NO	PART NO	DESCRIPTION	QTY	UNIT

RoHS compliant
Unit:: mm

Scale	FREE	⑤	Add "CAT5E"	20.10.2017	Stephon	Date	Name
TOLERANCE		④	Add length for 20M and 30M	20.09.2017	Fred	Drawn	26.06.2015 Joanna
X.	±X	③	remove mark on the mould	29.06.2016	Joanna	Approved	20.10.2017 Stephon
X.X	±X	②	Add length for 300mm	18.05.2015	Joanna		
X.XX	±X	①	Add P/N and change tolerance	15.12.2015	Joanna		
DIM	TOL	①	Add P/N and change tolerance	15.12.2015	Joanna		
ANGLE	±X°	①	Drawn	26.06.2015	Joanna		
Angle	TOL	Id.	Modification	Date	Name		

Customer-No.	
ASSMANN WSW-No.	A-MCSP-80XXX/X
Drawing-No.	ASS 7425 CA
Replace	rev05
Sheet	