

---

**SAM9G15 / SAM9G25 / SAM9G35 / SAM9X25 / SAM9X35  
Evaluation Kit**

---

**USER GUIDE****Introduction**

---

This User Guide introduces the Evaluation Kit and describes the development and debugging capabilities running on Atmel® | SMART SAM9 ARM®-based Embedded MPUs as listed below:

- SAM9G15
- SAM9G25
- SAM9X25
- SAM9G35
- SAM9X35

The User Guide pertains to the following Evaluation Kit references:

- SAM9G15-EK
- SAM9G25-EK
- SAM9X25-EK
- SAM9G35-EK
- SAM9X35-EK

## Contents

---

- Board
  - One EK board
  - One of the five available CPU modules (CM)
    - SAM9G15-CM
    - SAM9G35-CM
    - SAM9X35-CM
    - SAM9G25-CM
    - SAM9X25-CM
  - One optional DM board featured in SAM9G15, SAM9G35, SAM9X35 kits only.
- Power supply
  - Universal input AC/DC power supply with US, Europe and UK plug adapters
  - One 3V Lithium Battery type CR1225
- Cables
  - One serial RS232 cable
  - One micro A/B-type USB cable
  - One RJ45 crossed cable
- A Welcome Letter

### Board Photo (Display module is optional)



## Related Documents

---

Title	Reference	Comment
SAM9G15 Datasheet	<a href="#">Atmel lit° 11052</a>	These documents provide technical support for each of the Atmel ARM-based Embedded MPU products supported by these Evaluation Kits.
SAM9G25 Datasheet	<a href="#">Atmel lit° 11032</a>	
SAM9X25 Datasheet	<a href="#">Atmel lit° 11054</a>	
SAM9G35 Datasheet	<a href="#">Atmel lit° 11053</a>	
SAM9X35 Datasheet	<a href="#">Atmel lit° 11055</a>	

The datasheets can be found on [www.atmel.com](http://www.atmel.com) at the SAM9G MPU and SAM9X MPU product sections.

## Table of Contents

---

<b>Introduction</b> .....	1
<b>Contents</b> .....	2
<b>Related Documents</b> .....	3
<b>Table of Contents</b> .....	4
<b>1. Specifications</b> .....	5
1.1 Kit Specifications .....	5
1.2 Board Specifications .....	5
<b>2. Power Up</b> .....	6
2.1 Power Up the Board .....	6
2.2 Sample Code and Technical Support .....	6
2.3 Recovery Procedure .....	7
<b>3. Hardware Overview</b> .....	8
3.1 Introduction .....	8
3.2 Computer Module (CM) .....	10
3.3 EK Board Description .....	28
3.4 Optional Display Module (DM) Board Hardware .....	82
<b>4. Revision History</b> .....	87

# 1. Specifications

## 1.1 Kit Specifications

Unpack and inspect the kit carefully. Contact your local Atmel distributor, should there be issues concerning the contents of the kit.

Figure 1-1. Unpacked Evaluation Kit



## 1.2 Board Specifications

Table 1-1. Evaluation Kit Specifications

Characteristics	Specifications
Clock speed	400 MHz PCK, 133 MHz MCK
Ports	Ethernet, USB, RS232, DBGU, JTAG, CAN, Audio, SD Card
Board supply voltage	5 VDC from connector
Temperature	
- operating	-10° to +50° C
- storage	-40° to +85° C
Relative humidity	0 to 90% (non condensing)
Dimensions	
EK (Evaluation Kit)	165 mm x 135 mm
CM (Computer Module)	67.6 mm x 35 mm
DM (Display Module)	135 mm x 80 mm
RoHS status	Compliant

## 2. Power Up

### 2.1 Power Up the Board

Unpack the board taking care to avoid electrostatic discharge. Unpack the power supply, select the right power plug adapter corresponding to that of your country, and insert it in the power supply.

Connect the power supply DC connector to the board and plug the power supply to an AC power plug.

For SAM9G15, SAM9G35, SAM9X35 kits which contain LCD, the screen should light up and display the welcome page of a graphic demo. Click or touch icons displayed on the screen and enjoy the demo.

For SAM9G25 and SAM9X25 which do not contain LCD, before power up, connect DBGU port J11 on the EK board (refer to [Section 3.3.3.4](#) for details) to RS232 port on your computer through the RS232 cable provided with the kit. It is recommended to open a communication session under HyperTerminal. After power up, a command-line based demo runs that can be monitored on HyperTerminal window.

### 2.2 Sample Code and Technical Support

After boot up, designers can run sample code or their own application, on the development kit. Users can download sample code and get technical support from the Atmel web site:

[http://www.atmel.com/products/at91/default.asp?category\\_id=163&family\\_id=605&source=global\\_nav](http://www.atmel.com/products/at91/default.asp?category_id=163&family_id=605&source=global_nav)

Figure 2-1. Atmel Web Site



Note: Different interfaces on the EK boards share the same connections to the CPU module. Therefore the actual usage depends on the CPU module featured in the evaluation kit.

## 2.3 Recovery Procedure

All EK boards have passed strict test procedures before shipment. These test procedures are contained in the SPI serial Flash in case users need to examine the boards again at any time.

If the contents of the SPI serial Flash have been deleted, follow the instructions below to recover the state as it was when shipped by Atmel.

1. Go to the page on [atmel.com](#) for the EK being used.
2. Locate the EK Design & Manufacturing Files as shown in [Figure 2-2](#).
3. Find the `xxx-EK_test_12_public.zip`, which is the file for Flash content burning.
4. Follow the step-by-step instructions in the file `SAM9X5_EK_Test_Software` to recover the content and to test each section of the boards.

**Figure 2-2. EK Design & Manufacturing Files**

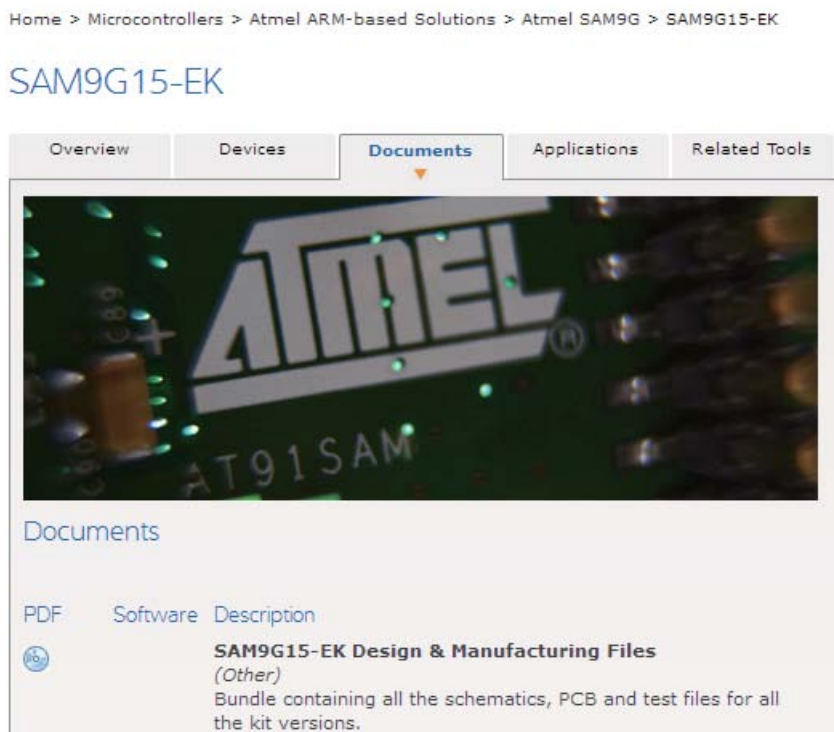

## 3. Hardware Overview

### 3.1 Introduction

The Evaluation Kit is a fully-featured evaluation platform for the Atmel MPU. The Evaluation Kit enables users to extensively evaluate, prototype and create application-specific designs.

The Evaluation Kit is a new platform architecture based on a Main Board (MB), a CPU Module (CM) equipped with one of the five processors and an optional Display Module (DM).

The Evaluation Kit consists of three boards:

1. The CPU Module (CM) board, is a single-board computer that integrates all the core components and is mounted onto an application-specific carrier board (EK board). The CPU Module has specified pinouts based on the SODIMM200 connector. It provides the functional requirements for an embedded application. These functions include, but are not limited to, graphics, audio, mass storage, network and multiple serial and USB ports. A single SODIMM200 connector provides an interface for the carrier board to carry all the I/O signals to and from the CPU Module.
2. The Evaluation Kit board (EK Main Board) provides all the interface connectors required to attach the system to the application specific peripherals. This versatility allows the designer to create a densely packed solution, which results in a more reliable product while simplifying system integration.
3. The optional Display Module (DM) board integrates LCD, TouchScreen and QTouch<sup>®</sup> technology.

[Table 3-1](#) lists the features provided on the Evaluation Kit:



**Table 3-1. Evaluation Kit Features**

Supported Modules			Product Name				
Expansion Slot	SO-DIMM200						
Processor Options			SAM9G15	SAM9G25	SAM9G35	SAM9X25	SAM9X35
LAN	MII/RMII Ethernet 10/100 w/PHY and three Led status	ETH0	–	X	X	X	X
	RMII Ethernet 10/100 w/PHY and three Led status	ETH1	–	–	–	X	–
USART/UART	RS232 four wires/RS485 Shared interface	COM0	X	X	X	X	X
	RS232 four wires	COM3	–	X	–	X	–
	RS232 two wires	DBGU	X	X	X	X	X
CAN	CAN interface Shared interface	CAN0	–	–	–	X	X
		CAN1	–	–	–	X	X
USB	2 * USB 2.0 Host	–	X	X	X	X	X
	1 * USB 2.0 Host/Device	–	X	X	X	X	X
SMD	Software Modem Device	–	X	X	X	X	X
Memory Card Support	µSD Card Slot Onboard	HSMCI0	X	X	X	X	X
	MMC/MMC+/SD/SDIO/CE-ATA	HSMCI1	X	X	X	X	X
ISI	–	–	–	X	–	–	–
LCD + Touch Screen	24-bit Output Mode	–	X	–	X	–	X
ZigBee®	–	–	X	X	X	X	X
SPI	–	–	X	X	X	X	X
TWI	–	–	X	X	X	X	X
DEBUG	JTAG Test Access Port	–	X	X	X	X	X

## 3.2 Computer Module (CM)

### 3.2.1 CM Board Overview

The CM board is the CPU module at the heart of the system. It connects to the EK board through a SO-DIMM200 interface. It carries the processor and external memories. The CM board serves as a minimal CPU sub-system. All five processors: SAM9G15, SAM9G25, SAM9X25, SAM9G35 and SAM9X35 share the same CM circuitry with minor configuration settings.

Note: There are three CM boards from three different manufacturers. The five processors are implemented as shown in [Table 3-2](#) below:

**Table 3-2. CM Board Implementation**

Manufacturer & Module kind	SAM9G15-CM	SAM9G25-CM	SAM9G35-CM	SAM9X25-CM	SAM9X35-CM
mfg 1	x	–	x	–	–
mfg 2	–	–	–	x	x
mfg 3	x	x	x	x	x

The three CM boards share the same circuitry design but with different designator information and PCB layouts. The circuitry reference in this guide, for common design parts, refers to schematics from SAM9G25-CM (mfg 3). All the other schematics are provided in [Section 3.2.6 "Schematics"](#).

**Figure 3-1. Board Architecture**

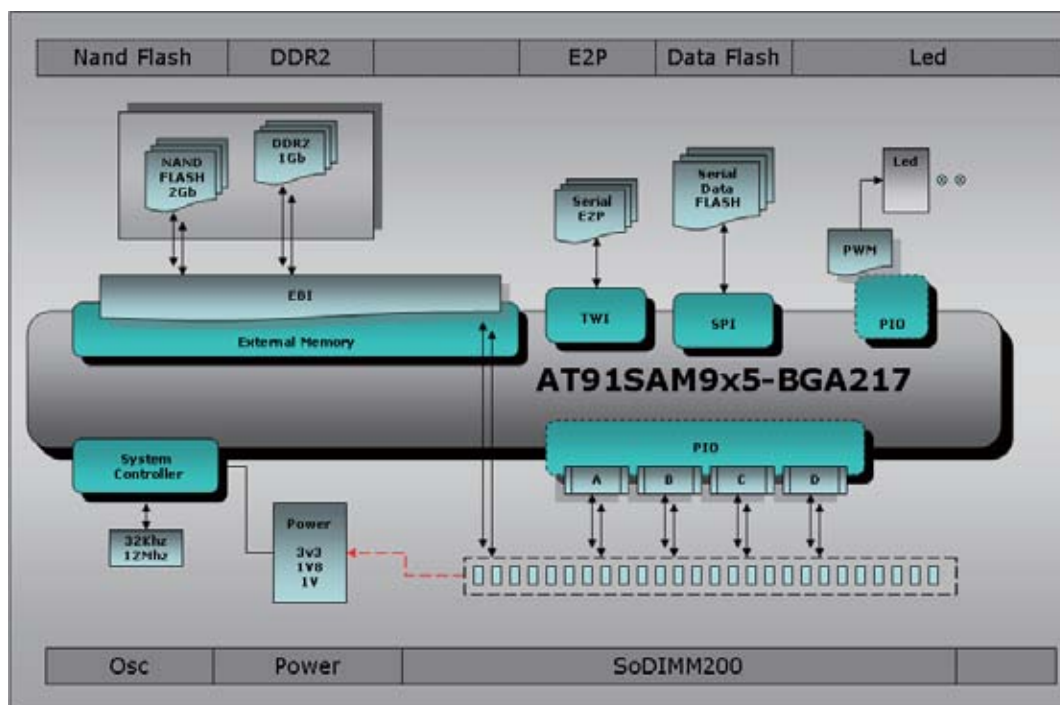

## 3.2.2 Equipment List

The CM board is built around the integration of an ARM926-based microcontroller (BGA217 package) with external memory and optional Ethernet Physical Layer Transceiver.

### 3.2.2.1 Devices

Following is the list of the CM board components:

- One SAM9 Embedded MPU from the list below
  - SAM9G15
  - SAM9G25
  - SAM9G35
  - SAM9X25
  - SAM9X35
- 12 MHz crystal
- 32.768 KHz crystal
- 1 Gbit DDR2 memory
- 2 Gits NAND Flash memory with Chip Selection control switch
- 32 Mbits SPI Serial Flash with Chip Selection control switch
- 512 Kbits EEPROM
- 1 Kbyte 1-Wire EEPROM
- On-board power regulation
- Two user LEDs
- Optional PHY

### 3.2.2.2 Interface Connection

- SODIMM200 card edge interface

### 3.2.2.3 Configuration Items

- Dual ON/OFF switch for NAND Flash and SPI serial Flash Chip Select connection

Figure 3-2. CM Board Layout Commented

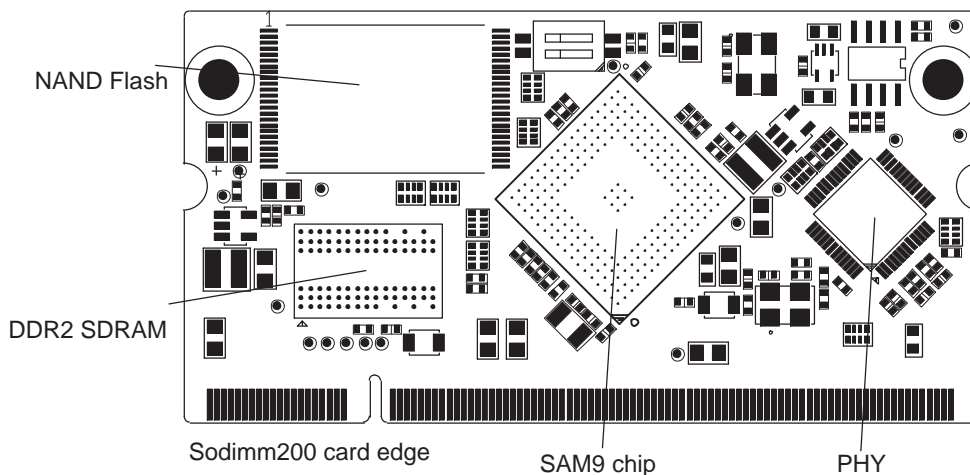

### 3.2.3 Function Blocks

#### 3.2.3.1 Processor

The CM Board is equipped with an Atmel ARM-based embedded MPU, as listed below, in a 217-ball BGA package. The five devices share an identical footprint. All five share the same CM Board PCB with minor configuration differences.

The five devices are:

- SAM9G15
- SAM9G25
- SAM9G35
- SAM9X25
- SAM9X35

As different interfaces can be defined using the same pins, it depends on the actual configuration of the CPU as to which functions are in fact available to the EK board.

Refer to [Section 3.2.4.1 "Chip Identification"](#) for details. The processor runs at a nominal frequency of 400 MHz for the core and 133 MHz for the system bus.

The peripheral configuration possibilities and implementation requirements of the CM are dependent on the module's chipset. Two configuration resistors are implemented on board in order to select the mode of configuration.

#### 3.2.3.2 Clock Circuitry

The CM includes 3 clock sources:

- Two are alternatives for the processor main clock
- One crystal and one crystal oscillator are used for the Ethernet MII/RMII chip

**Table 3-3. Main Components Associated with the Clock Systems**

Quantity	Description	Component assignment
1	Crystal for Internal Clock, 12 MHz	Y1
1	Crystal for RTC Clock, 32.768 kHz	Y2
1	Oscillator for Ethernet Clock RMII, 50 MHz	Y3

#### 3.2.3.3 Reset Circuitry

The reset sources for the CM board are:

- Power on reset
- Push button reset (Push button is equipped on EK board)
- JTAG reset from an in-circuit emulator (JTAG interface is equipped on EK board)

### 3.2.3.4 Power Supplies

The CM Board is driven by +3V3 input power rail from the EK board through the SODIMM200 connector. The CM Board embeds all the necessary power rails required for the micro processor.

When additional voltages are required, for example VDDCORE, they are generated on board from the 3.3V supply. The detailed power supply requirements for any given module are specified within the corresponding product documentation. The following table summarizes the power specifications.

**Table 3-4. Power Rails Associated with the Systems**

Nominal	Name	Powers	Component
3.3v	VDDNF	the NAND Flash I/O and control, D16-D32 and multiplexed SMC lines	From SODIMM200 connector
3.3v	VDDIOP0	Partial Peripheral I/O lines	From SODIMM200 connector
3.3v	VDDIOP1	Partial Peripheral I/O lines	From SODIMM200 connector
3.0v	VDDBU	the Slow Clock oscillator, the internal 32 kHz RC, the internal 12 MHz RC and a part of the System Controller	From SODIMM200 connector
3.3v	VDDUTMII	the USB device and host UTMI+ interface	From SODIMM200 connector
3.3v	VDDOSC	the Main Oscillator cells	From SODIMM200 connector
3.3v	VDDANA	the Analog to Digital Converter	From SODIMM200 connector
1.8v	VDDIOM	the External Memory Interface I/O lines	on-board
1.0v	VDDUTMIC	DC Supply UDPHS and UPHPS UTMI+ Core	on-board
3.3v	VDDPLLUTMI	DC Supply UDPHS and UPHPS UTMI+ Interface	From SODIMM200 connector
1.0v	VDDPLLA	the PLLA cell	on-board
1.0v	VDDCORE	the core, including the processor, the embedded memories and the peripherals	on-board
3.0V or 3.3V configurable	ADVREF	ADC Reference voltage	From SODIMM200 connector

Figure 3-3. CM Power Supply

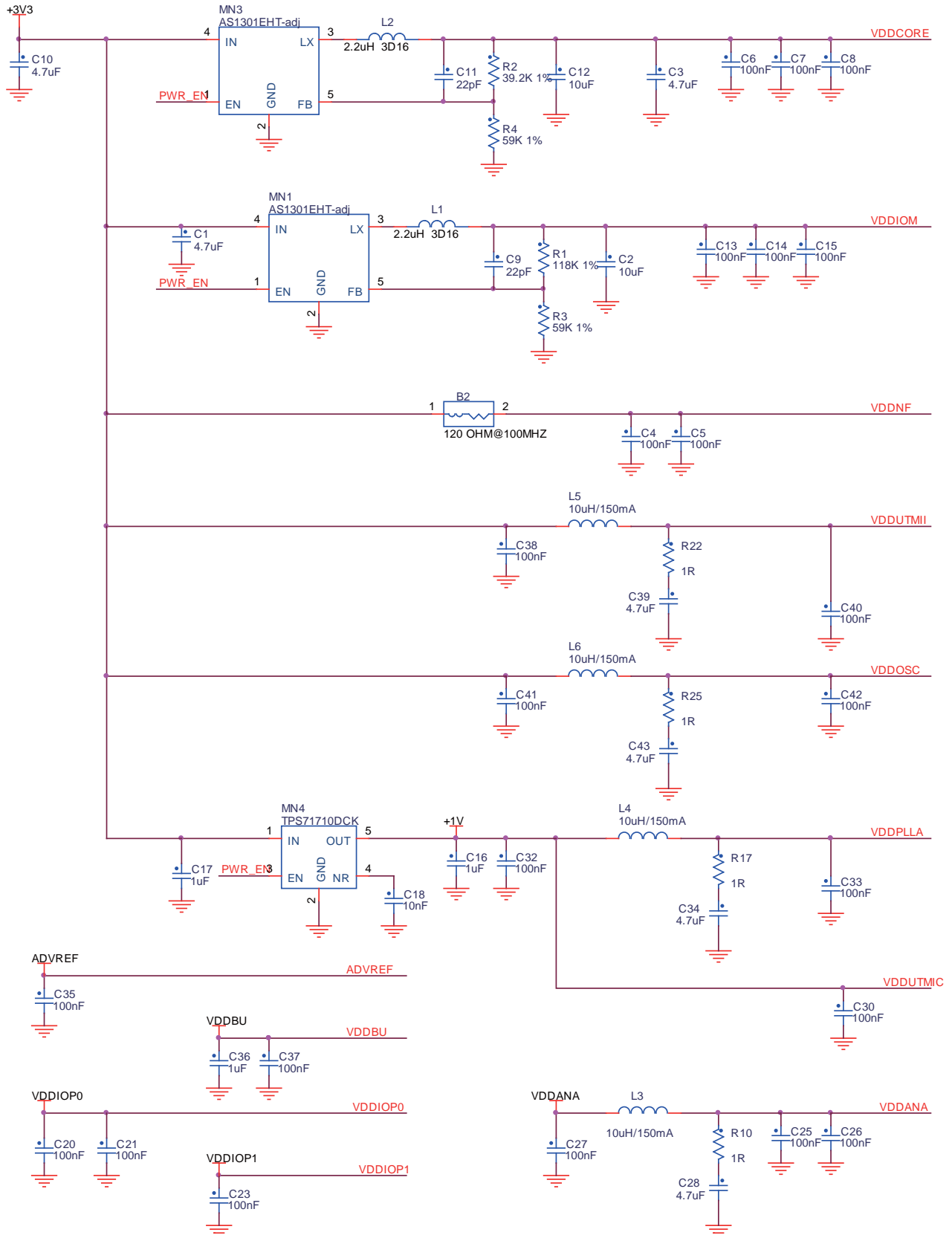

### 3.2.3.5 Memory

The Device serial processor features a DDR/SDR memory interface and an External Bus Interface (EBI) to enable interfacing to a wide range of external memories and to almost any kind of parallel peripheral.

The External Bus Interface (EBI) is connected to two kinds of memory devices:

- One 1 Gbyte DDR2 SDRAM
- One 2 Gbytes (or 4 Gbytes depending on supplier) NAND Flash

Figure 3-4. CM Board External Memory

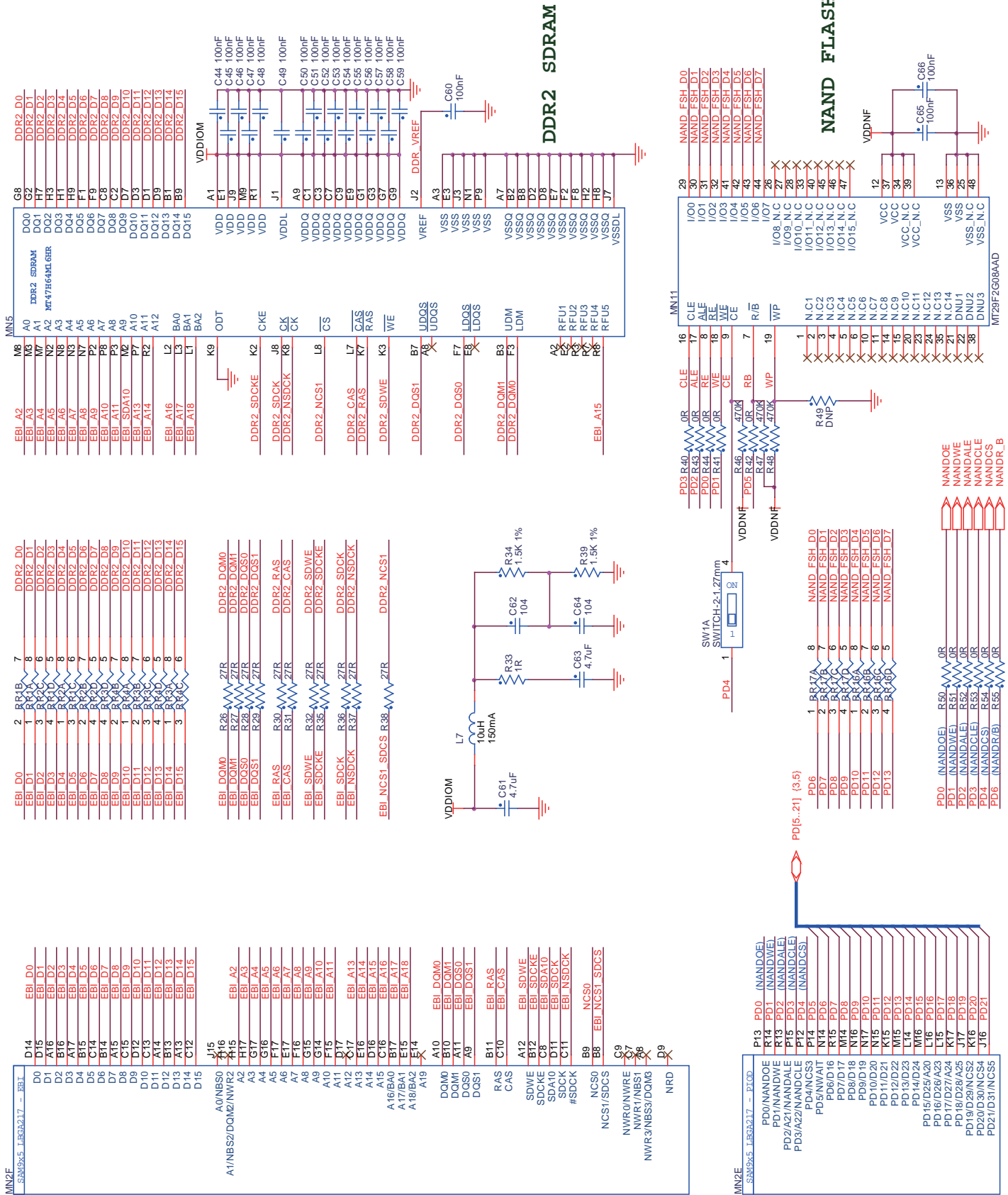



### 3.2.3.6 Serial Peripheral Interface (SPI) Controller

The serial processor provides two high-speed Serial Peripheral Interface (SPI) controllers. One port is used to interface with the on-board serial Flash.

Figure 3-5. SPI

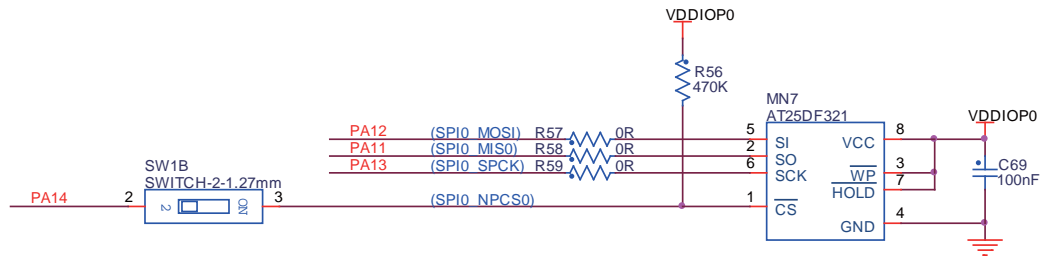

### 3.2.3.7 Two Wire Interface (TWI)

The serial processor has a full speed (400 kHz) master/slave TWI Serial Controller. The controller is mostly compatible with industry standard I2C and SMBus Interfaces. This port is used to interface with the on-board Serial EEPROM, ISI, QTouch device and audio codec interface.

Figure 3-6. TWI

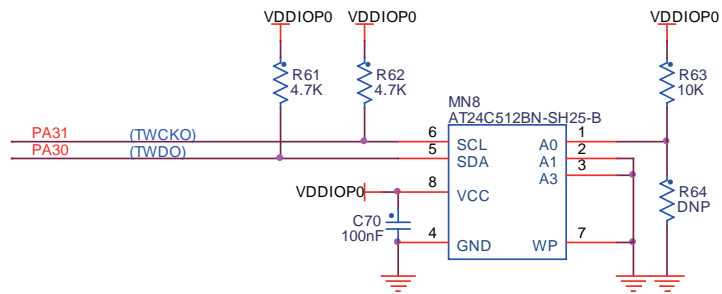

### 3.2.3.8 1-Wire EEPROM

The Evaluation Kit uses a 1-Wire device as “firmware label” to store the information such as chip type, manufacturer’s name, production date etc.

Figure 3-7. 1-Wire Device

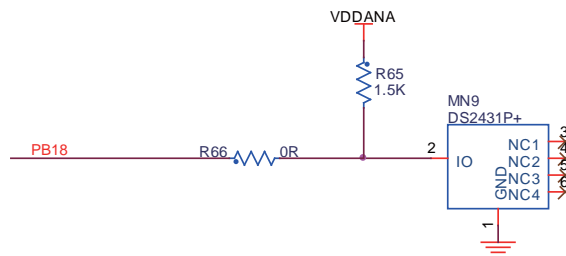

### 3.2.3.9 Optional PHY

Some of the device modules provide a location for a 10/100 Ethernet MAC/PHY interface.

For more information about the Ethernet controller device, refer to the Davicom DM9161 controller manufacturer's datasheet.

Figure 3-8. Ethernet

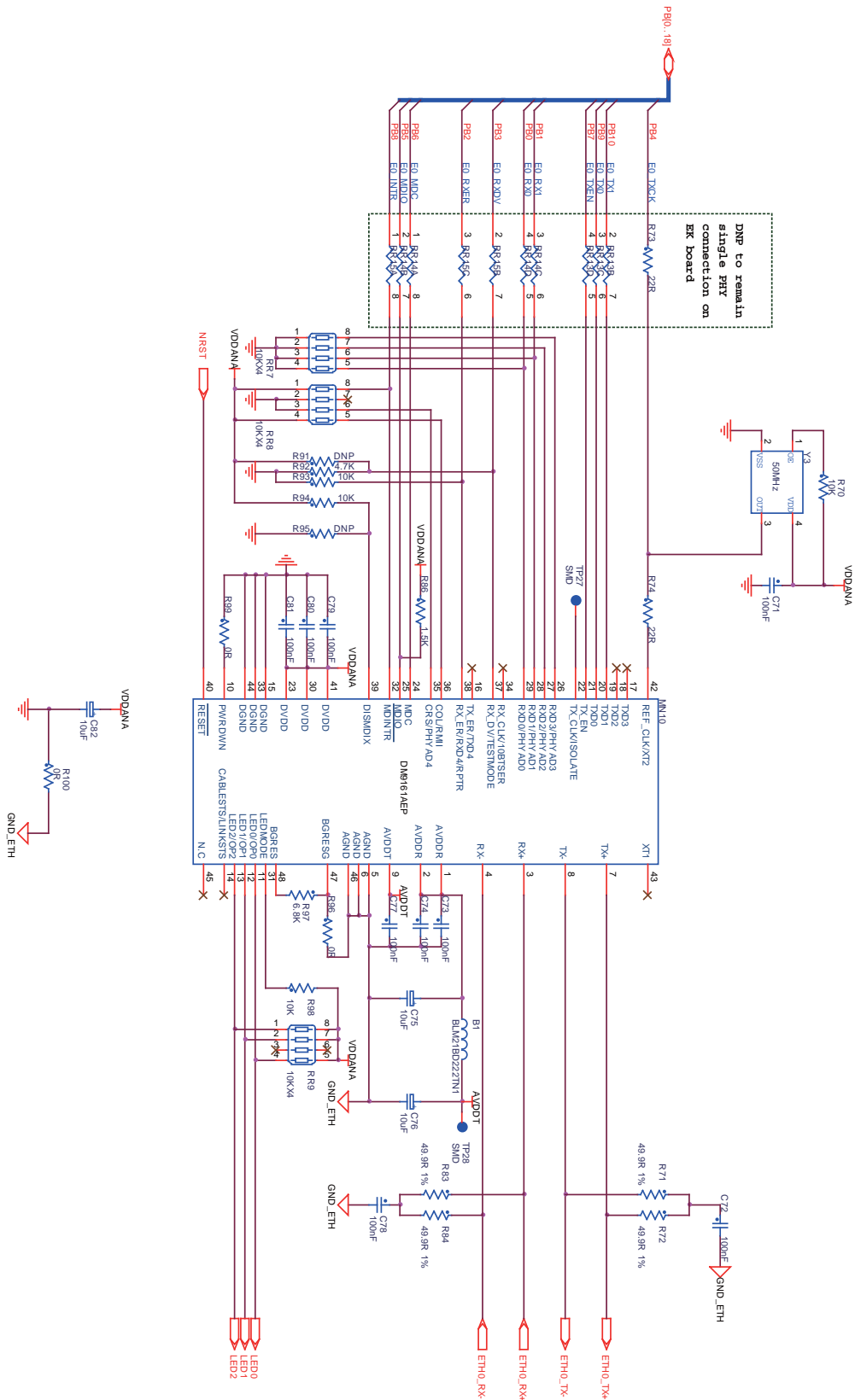

### 3.2.3.10 SODIMM200 Interface

The CM board uses SODIMM200 card edge connector to interface with the EK board.

Figure 3-9. SODIMM200 Interface on CM Board

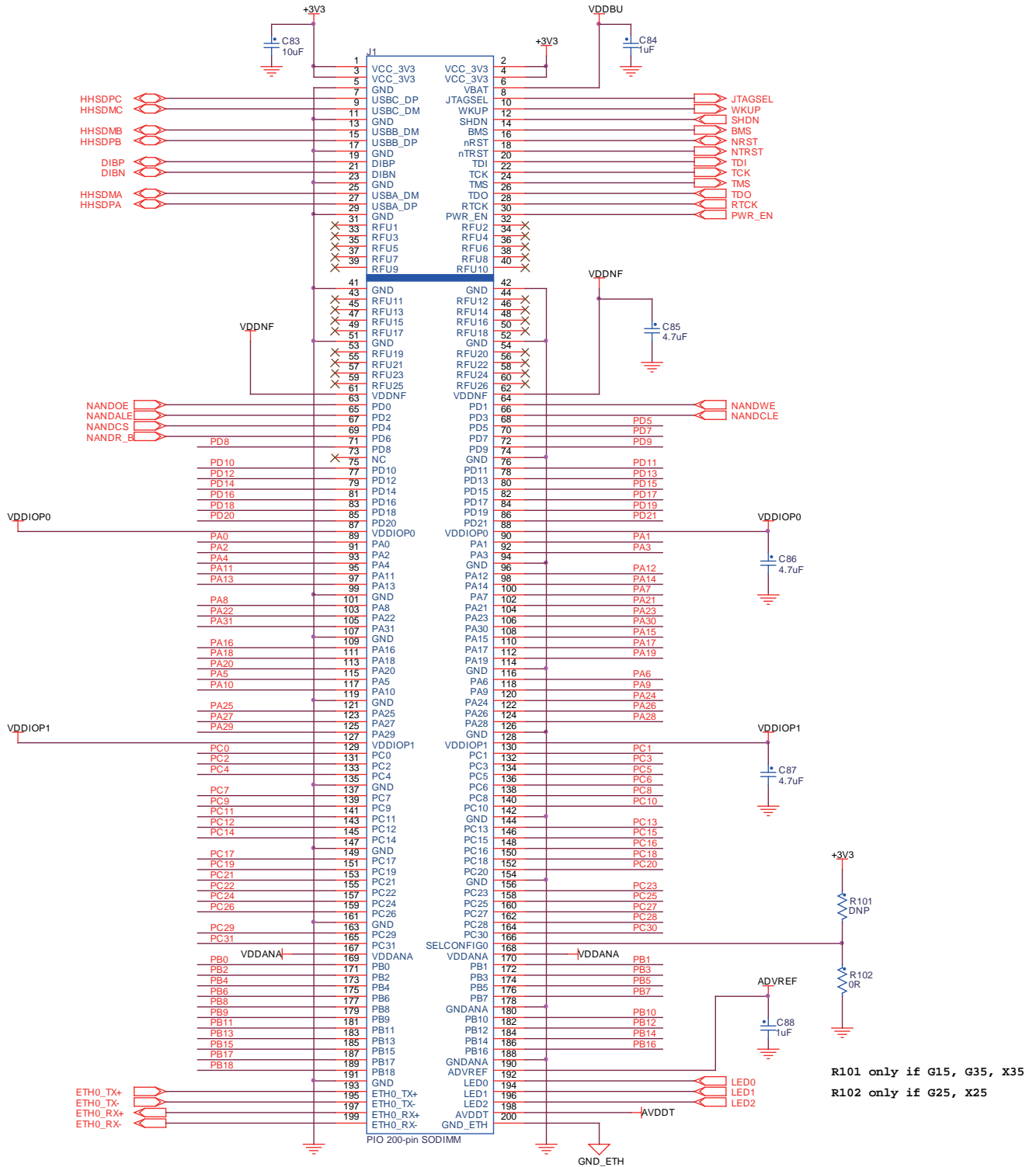

## 3.2.4 Configuration

### 3.2.4.1 Chip Identification

The CM board may be equipped with any of the five processors, all sharing an identical BGA217 footprint. There are two resistors on the CM board for the purpose of identifying which of the five is the one actually mounted.

The tables below show in detail how the CM board, relative to different processors, determines the dedicated “SELCONFIG” logic.

**Table 3-5. Resistor Identification**

Resistor	SAM9G15	SAM9G25	SAM9G35	SAM9X25	SAM9X35
R49	–	–	–	Populated	Not Populated
R50	–	–	–	Not Populated	Populated
R87	Populated	–	Populated	–	–
R88	Not Populated	–	Not Populated	–	–
R101	Populated	Not Populated	Populated	Not Populated	Populated
R102	Not Populated	Populated	Not Populated	Populated	Not Populated

**Table 3-6. Module Configuration Identification**

		SAM9G15 module	SAM9G35 module	SAM9X35 module	SAM9G25 module	SAM9X25 module
CM Setting	R101	Populated	Populated	Populated	Not Populated	Not Populated
	R102	Not Populated	Not Populated	Not Populated	Populated	Populated
	SELCONFIG (SODIMM200 pin 166)	High	High	High	Low	Low
EK Setting	USART3	Not Selected	Not Selected	Not Selected	Selected	Selected
	ETH1	Not Selected	Not Selected	Not Selected	Not Selected	Selected
DM Setting	LCD	Selected	Selected	Selected	Not Selected	Not Selected

### 3.2.4.2 Boot Configuration

In order to use the SAM-BA boot, users must ensure that JP9 (BMS configuration) on the board is open, so that the embedded ROM code runs and searches for a bootable device. For more details, refer to the product datasheet. To make the processor boot from SAM-BA, the external memory devices cannot be bootable.

All three CM boards from different vendors feature a de-select function of the Chip Select signal on NAND and SPI serial Flash.

To boot from software, users may erase the bootable content within NAND and SPI serial Flash to launch a SAM-BA boot. A hardware disconnection of the Chip Select signal is not necessary.

**Table 3-7. Boot Configuration**

Board Vendor	Designation	Default Setting	Feature
Embest CM	SW1A (1,4)	ON	<ol style="list-style-type: none"> <li>1. Default ON to select NAND Flash</li> <li>2. Set to OFF to deselect the NAND Flash</li> </ol>
	SW1B (2,3)	ON	<ol style="list-style-type: none"> <li>1. Default ON to select SPI serial Flash</li> <li>2. Set to OFF to deselect the SPI serial Flash</li> </ol>
Ronetix CM	J1 R17	J1 DNP R17 populated	<ol style="list-style-type: none"> <li>1. Default select NAND Flash always</li> <li>2. Users need to dismount R17, mount J1 as 2.54mm jumper to ease frequent changes</li> <li>3. Close J1 to select NAND Flash Open J1 to deselect NAND Flash</li> </ol>
	J2 R24	J2 DNP R24 populated	<ol style="list-style-type: none"> <li>1. Default select SPI serial Flash always</li> <li>2. Users need to dismount R24, mount J2 as 2.54mm jumper to ease frequent changes</li> <li>3. Close J2 to select SPI serial Flash Open J2 to deselect SPI serial Flash</li> </ol>
Cogent CM	P2 R90	P2 normal close R90 DNP	<ol style="list-style-type: none"> <li>1. By default, P2 is closed to select NAND Flash</li> <li>2. Open P2 to deselect NAND Flash</li> <li>3. Mounting R90 as 0-ohm always selects NAND Flash</li> </ol>
	R15	R15 populated	<ol style="list-style-type: none"> <li>1. Default select SPI serial Flash always</li> <li>2. Dismount R15 to deselect SPI serial Flash</li> </ol>

**Figure 3-10. SW1A and SW1B Position on Embest Modules**

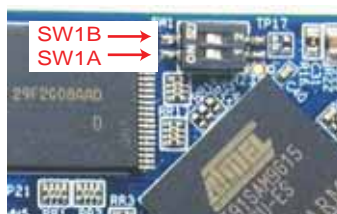

### 3.2.5 Connectors

Figure 3-11. CM Board Dimensions

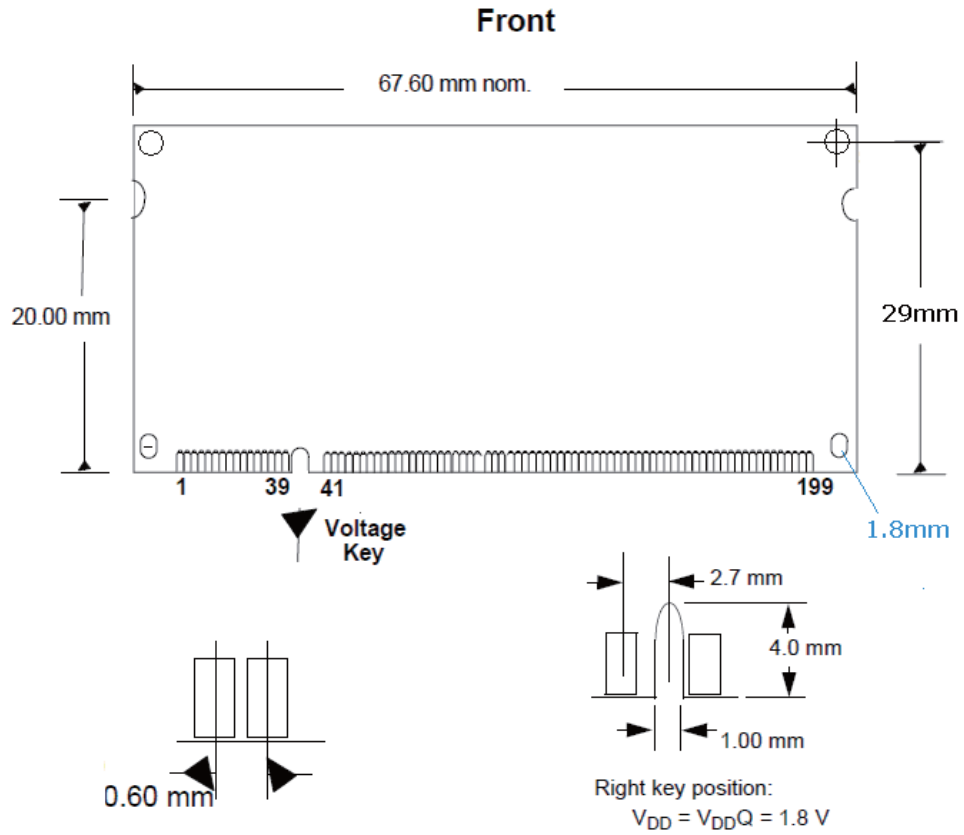

### 3.2.6 Schematics

Figure 3-12. CM Board Schematics – 1 of 5

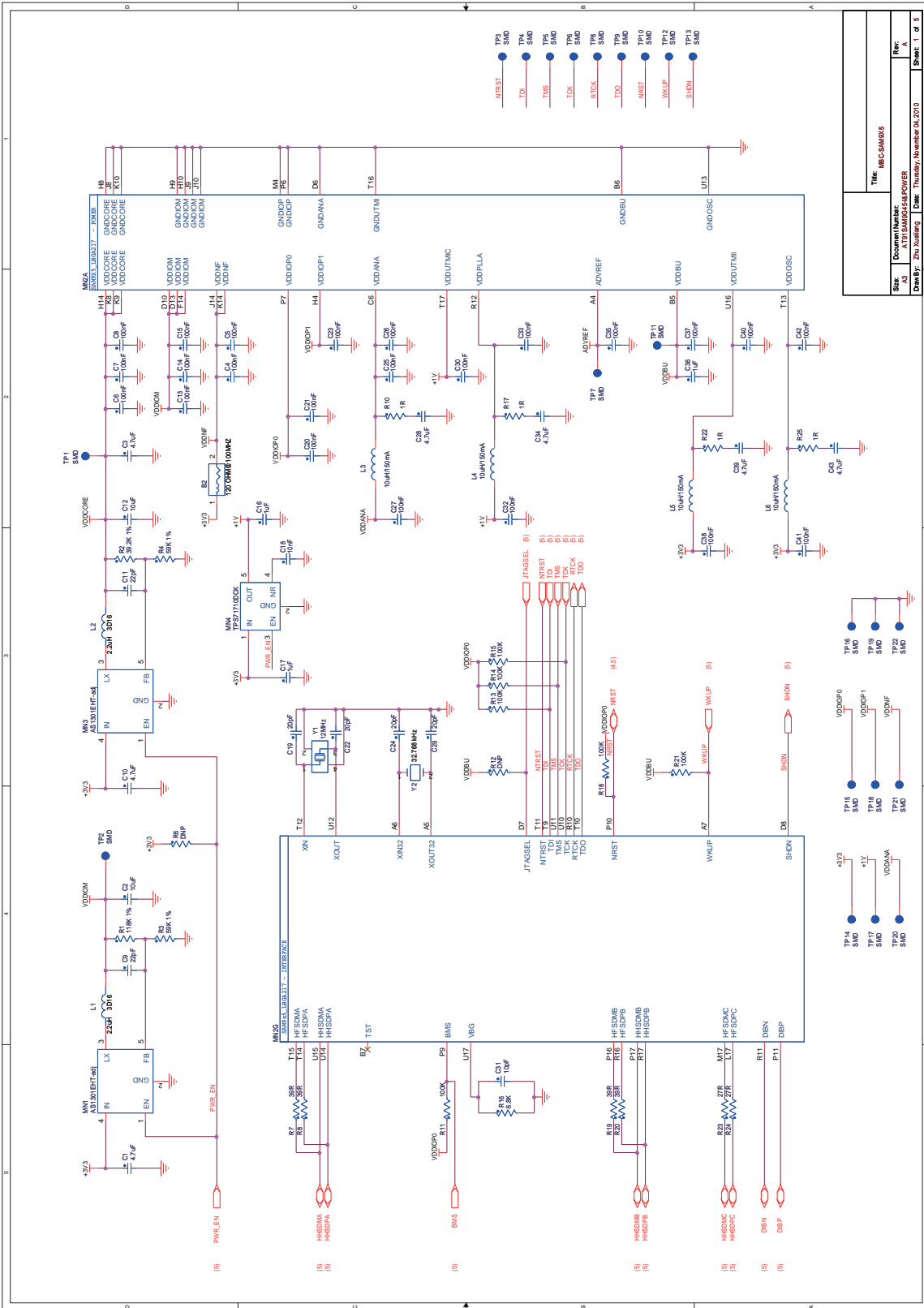

Figure 3-13. CM Board Schematics – 2 of 5

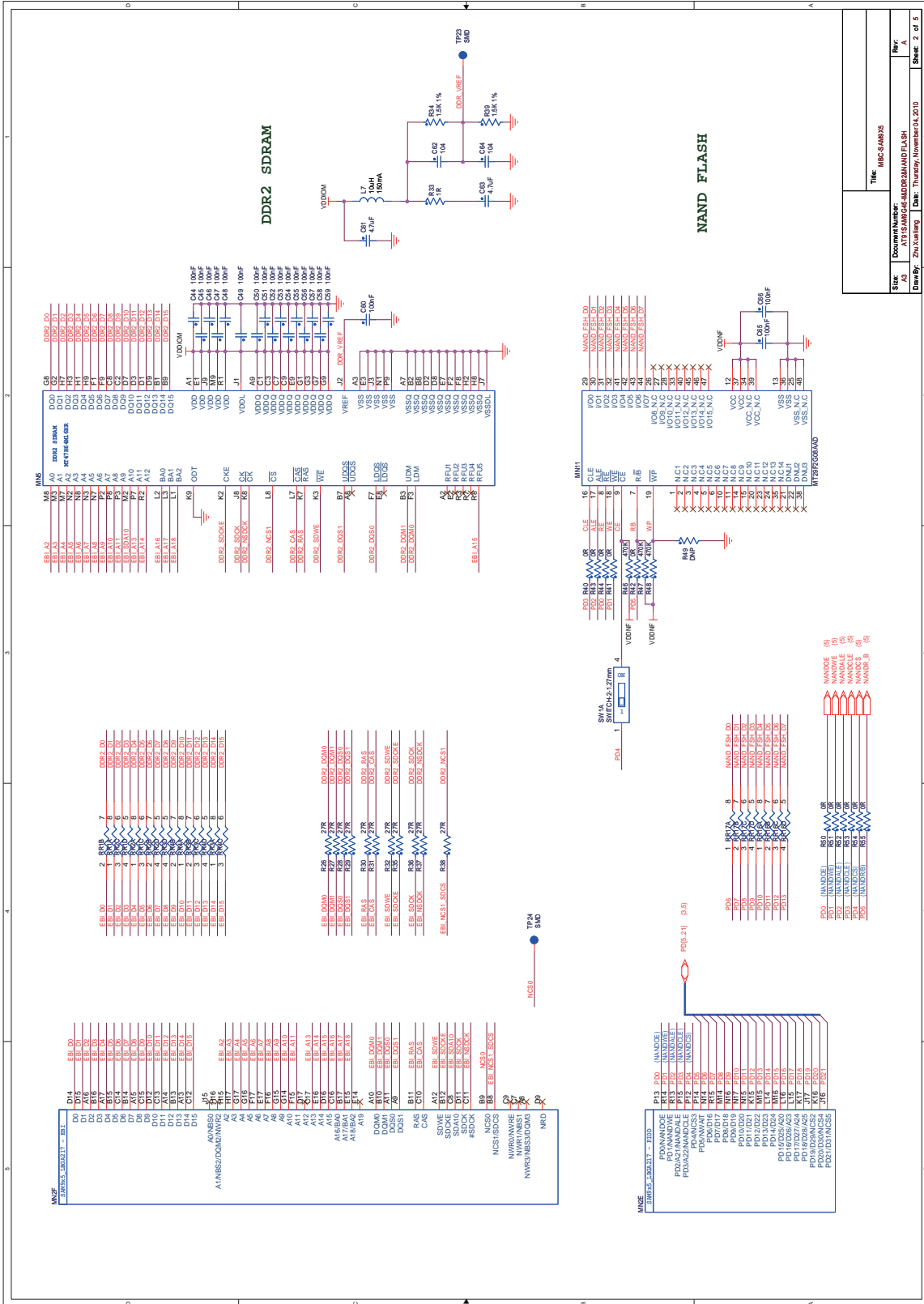
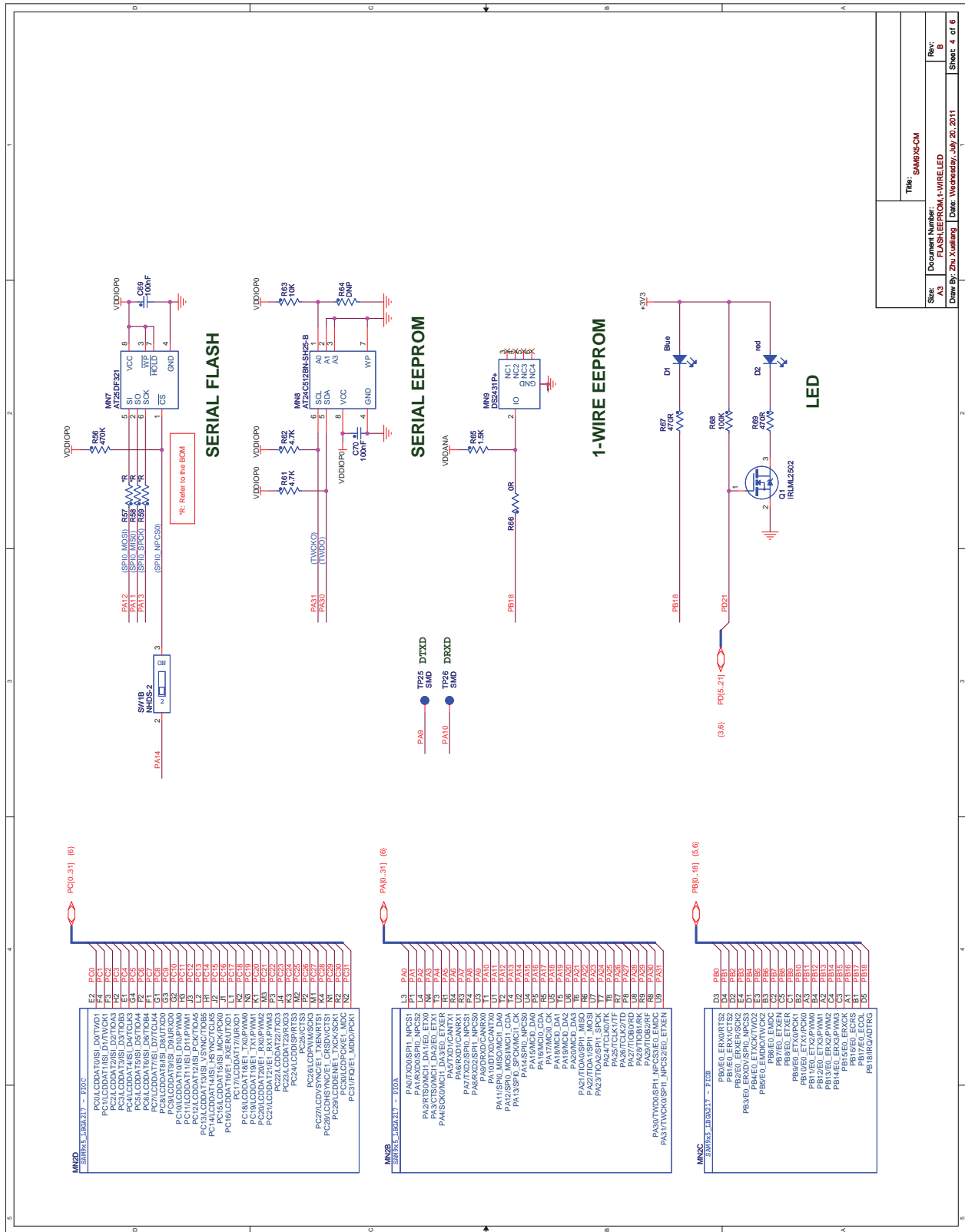

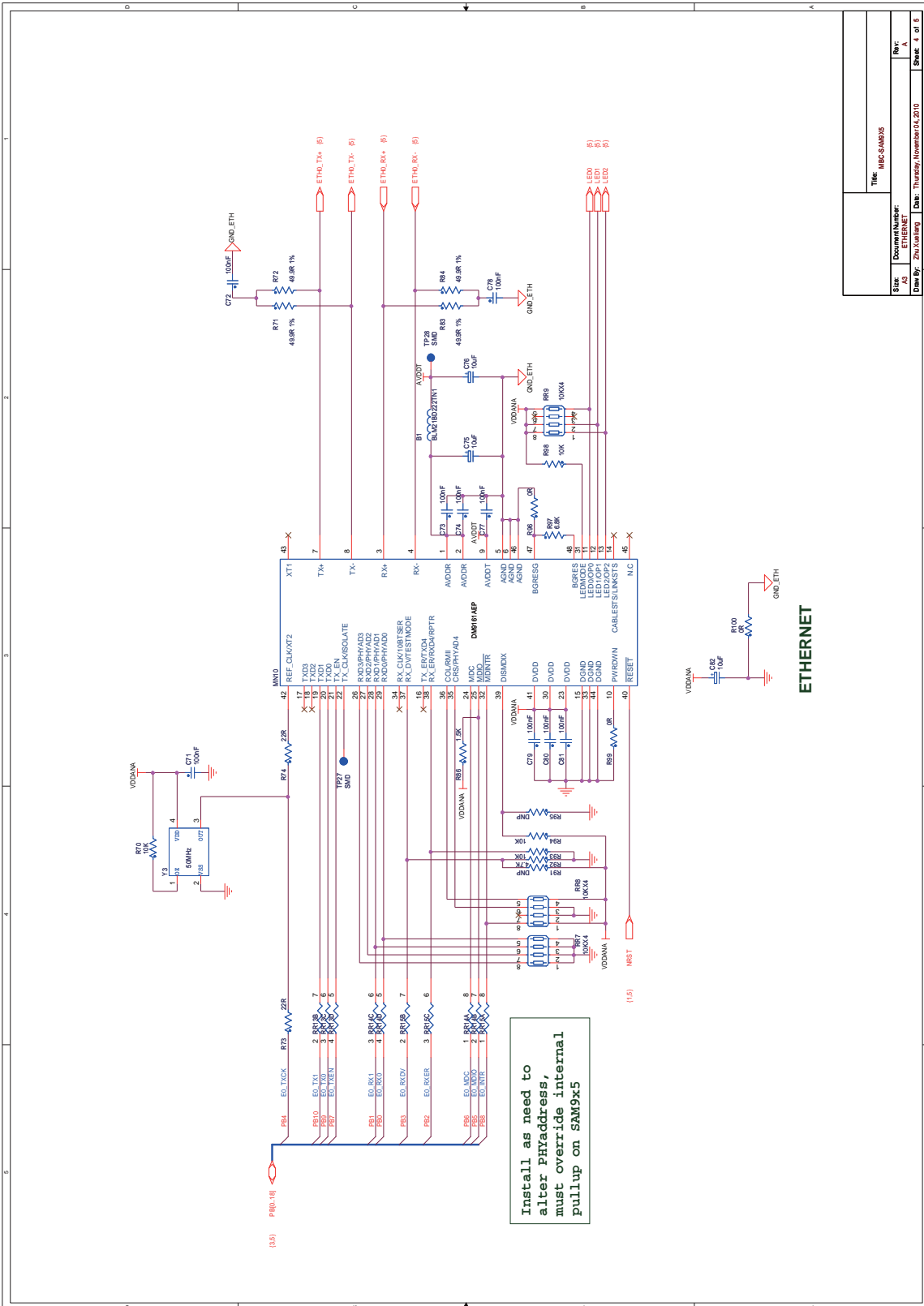

Figure 3-14. CM Board Schematics – 3 of 5



Title: SAM935-CM	
Size: A3	Document Number: FLASH EEPROM 1-WIRE LED
Drawn By: Zhu Xueliang	Date: Wednesday, July 20, 2011
Rev: B	Sheet: 4 of 6

Figure 3-15. CM Board Schematics – 4 of 5





## 3.3 EK Board Description

### 3.3.1 EK Board Overview

The EK board serves as the main board that carries the CPU module. It features all necessary peripherals and interfaces for processor evaluation.

Figure 3-17. Commented EK Board Layout

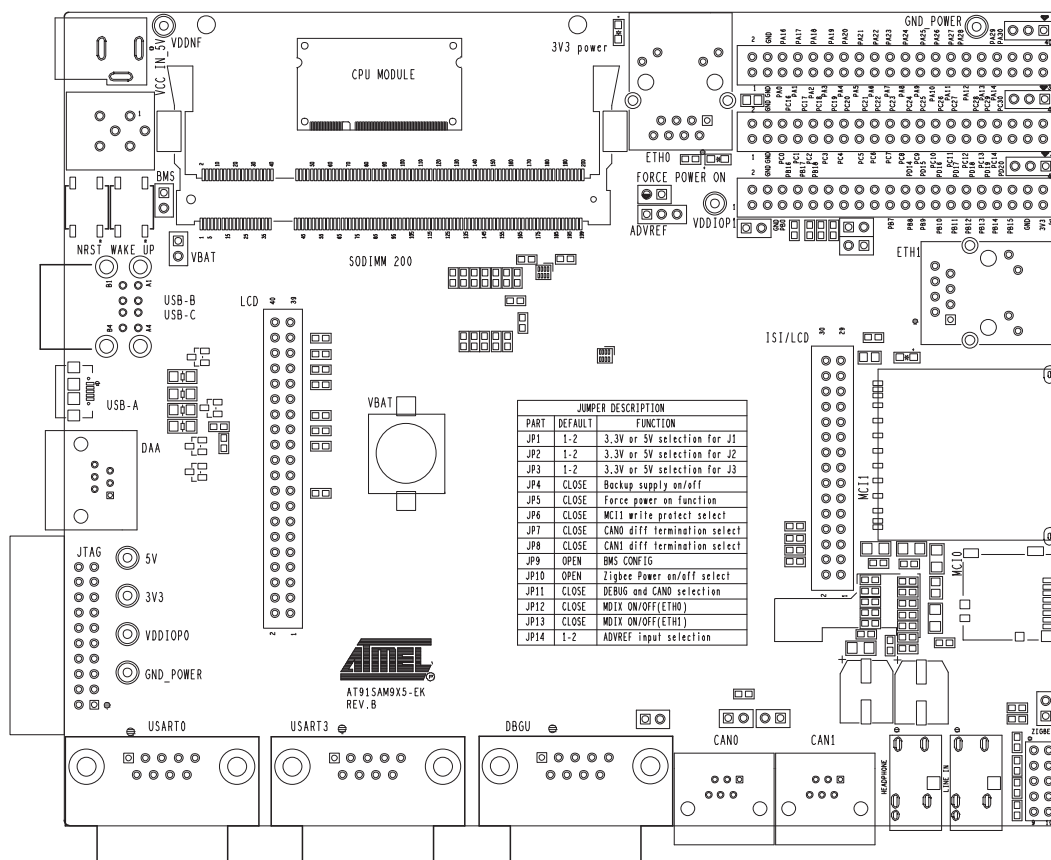

### 3.3.2 Equipment List

Based on the processor installed on the CM board, the EK board is equipped with the following interfaces or peripherals:

#### 3.3.2.1 Devices

List of the EK board peripherals:

- Two EMAC PHY
- One Audio codec
- Two high speed MCI Card interfaces
- Two CAN transceivers
- Three RS232 ports with level translator features: DBGU, USART0 and USART3
- One Smart DAA port
- Two USB host ports
- One USB host/device port
- On-board power regulation

- LCD/ISI extension interface
- ZigBee interface
- One-wire device

### 3.3.2.2 Board Interface Connection

- Main power supply (J4)
- One SODIMM200 socket (CON1)
- USB A Host/Device, support USB host/device using a type micro AB connector (J20)
- USB B Host, support USB host using a type A connector (J19, upper)
- USB C Host, support USB host using a type A connector (J19, lower)
- DBGU (RX and TX only) connected to a 9-way male RS232 connector (J11)
- USART1 (RX, TX, RTS, CTS) connected to a 9-way male RS232 connector (J8)
- USART3 (RX, TX, RTS, CTS) connected to a 9-way male RS232 connector (J12)
- JTAG, 20 pin IDC connector (J9)
- MicroSD connector (J6)
- SD/MMC connector (J7)
- Headphone (J15), line-in (J13)
- Image sensor connector (J21)
- DM board connection for QTouch and TFT LCD display with Touch Screen and backlight (J21, J22)
- DAA connector RJ11 6P4C type (J16)
- CAN bus connectors RJ12 6P6C type (CON2, CON3)
- ZigBee connector (J10)
- Three IO expansion ports (J1, J2, J3)
- Test points, various test points are located throughout the board

### 3.3.2.3 Push Button Switches

- Reset, board reset (BP1)
- Wake up, push button to bring the processor out of low power mode (BP2)

## 3.3.3 Function Blocks

### 3.3.3.1 Processor

The Evaluation Kit board may be used with any of the Core Modules:

- SAM9G15
- SAM9G25
- SAM9G35
- SAM9X25
- SAM9X35

Figure 3-18. SODIMM Interface on EK Board

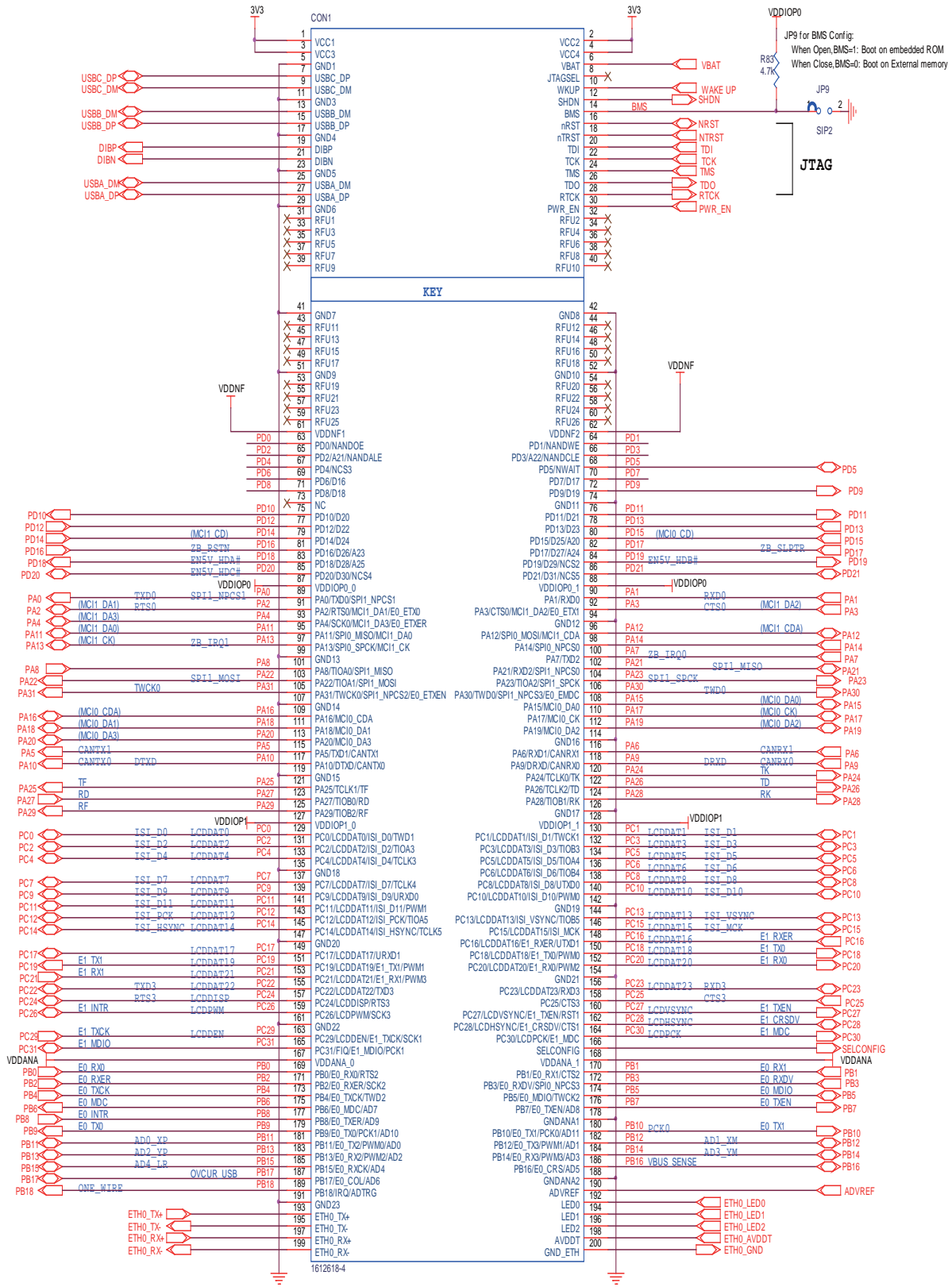

### 3.3.3.2 Power Supplies

The EK Board features one adjustable LDO. It accepts DC 5V power input and outputs a regulated +3.3V to most other circuits on the board through four 3.3V rails.

- VDDPIO0
- VDDPIO1
- VDDANA
- VDDISI

This LDO is enabled through a dual FET scheme. The processor can assert SHDN (which is a VDDBU- powered I/O) to shut down the LDO to enter the so-called backup mode. The regulator on CM board is also shut down by the action of the SHDN signal.

If the 3V battery is mounted on J5, both CM and EK boards can be woken up by action on the BP2 button, which drives the WKUP signal (also a VDDBU-powered I/O).

**Figure 3-19. EK Board Power Management**

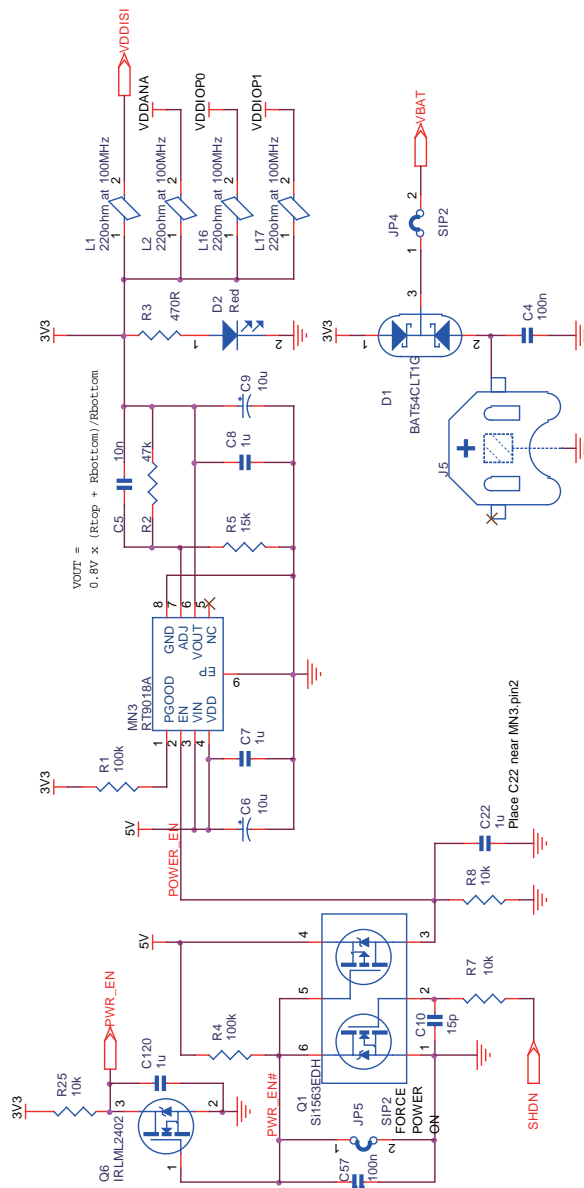

There is another 3.3V rail, VDDNF, supplied from the CM board. VDDNF is set to 3.3V in the current CM design. The processors also support a 1.8V NAND Flash device, in which case VDDNF is set to 1.8V. In order to avoid potential voltage conflict on user-defined applications, a level shifter is inserted between the PIO lines on VDDNF rail and the 3.3V application.

**Figure 3-20. Level Shifter For VDDNF Rail**

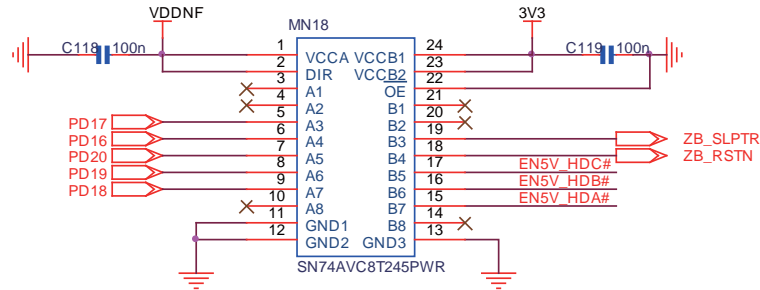

### 3.3.3.3 JTAG/ICE

Software debug is accessed by a standard 20-pin JTAG connection. This allows connection to a standard USB-to-JTAG in-circuit emulator such as SAM-ICE™.

**Figure 3-21. JTAG Interface**

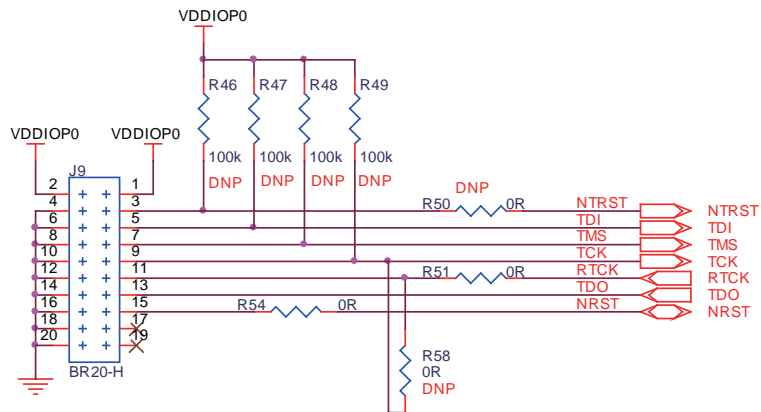



### 3.3.3.4 DBGU

The UART is connected to the DB-9 male socket through an RS-232 Transceiver (TXD and RXD only). A jumper, JP11, is used to select DBGU or CAN0 between IO (PA9, PA10) sharing scheme. Close JP11 to select DBGU.

**Figure 3-22. DBGU Com Port**

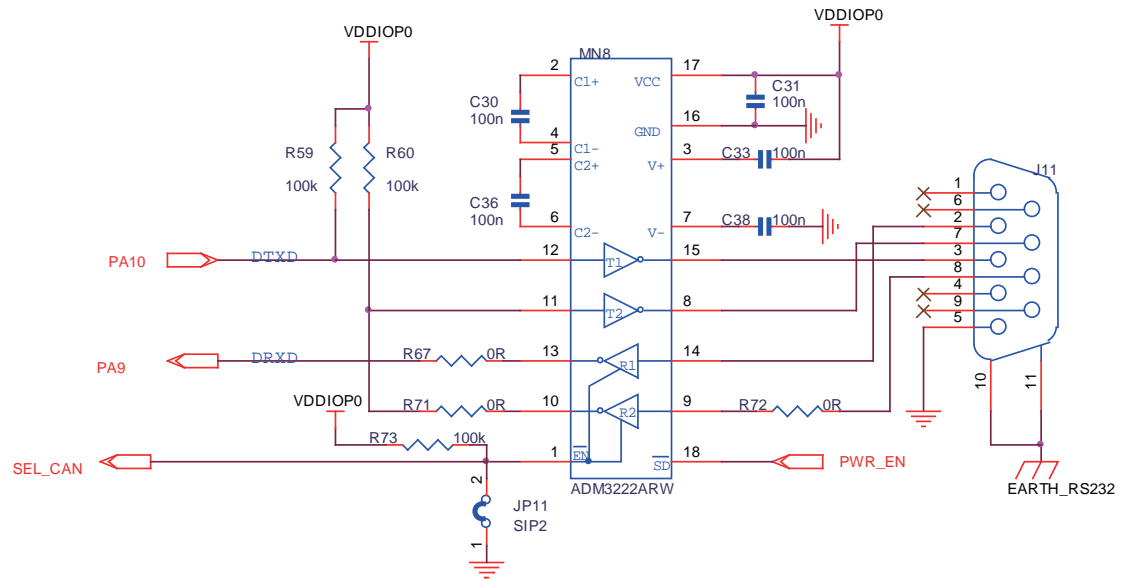



### 3.3.3.6 USB Ports

The Evaluation Kit features three USB communication ports:

- Port A Host High Speed (EHCI) and Full Speed (OHCI) multiplexed with USB Device High speed Micro AB connector, J20
- Port B Host High Speed (EHCI) and Full Speed (OHCI) standard type A connector, J19 upper port
- Port C Host Full speed OHCI only standard type A connector, J19 lower port

All three USB Host ports are equipped with 500 mA high-side power switch for self-powered and bus-powered applications. The USB device port features VBUS insert detection function through the resistor ladder R138 and R139.

Refer to the embedded MPU product datasheet for detailed programming information. For datasheet reference numbers and titles, see [“Related Documents”](#) .

**Figure 3-24. USB Port (A)**

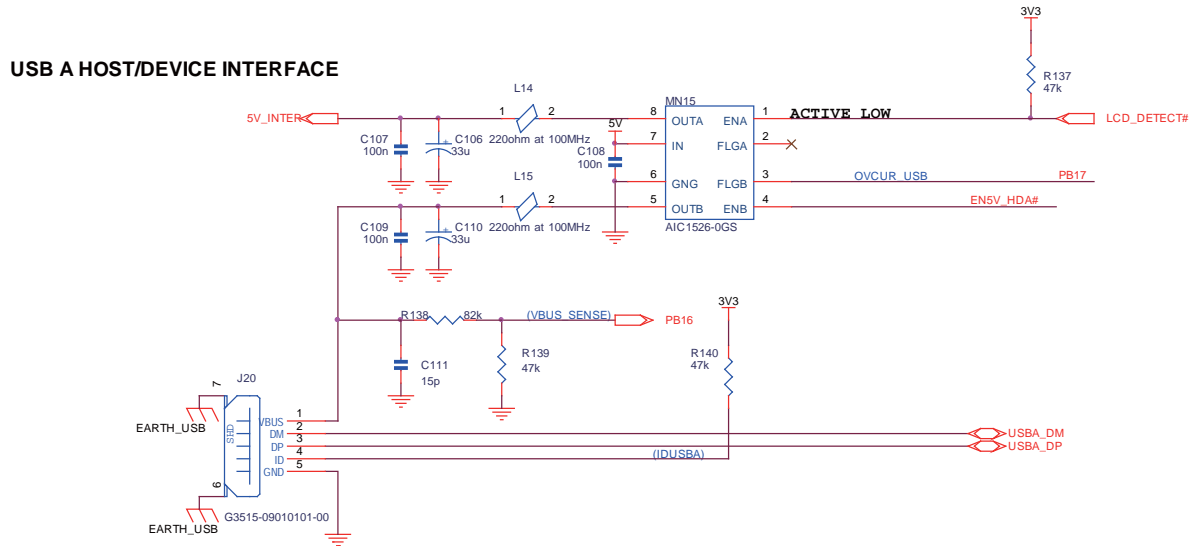

**Figure 3-25. USB Port (B & C)**

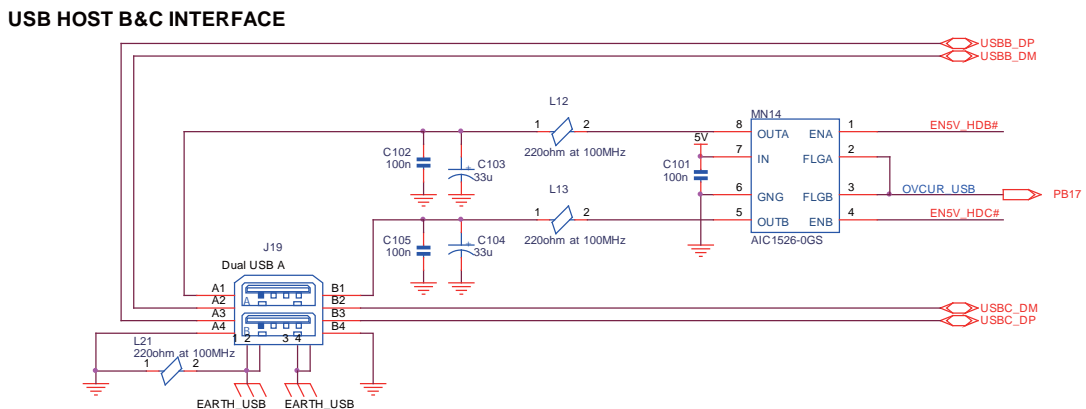

### 3.3.3.7 Ethernet 10/100 (EMAC) Port

Except for SAM9G15, the processor has two 10/100 Mbps Ethernet Mac Controllers.

	SAM9G15	SAM9G35	SAM9X35	SAM9G25	SAM9X25
EMAC	–	RMII	RMII	MII	MII + RMII

The EK board is equipped with two Davicom DM9161AEP PHYs for each Ethernet port. Both PHY Transceivers are configured as RMII mode. Both PHY transceivers have an RJ45 port with embedded transformer and three-status LEDs.

By default, the ETH0 interface is implemented on the EK board. Additionally, for monitoring and control purposes, an LED functionality is carried on the RJ45 connectors to indicate activity, link, and speed status information for the respective ports.

Figure 3-26. ETH0 Port

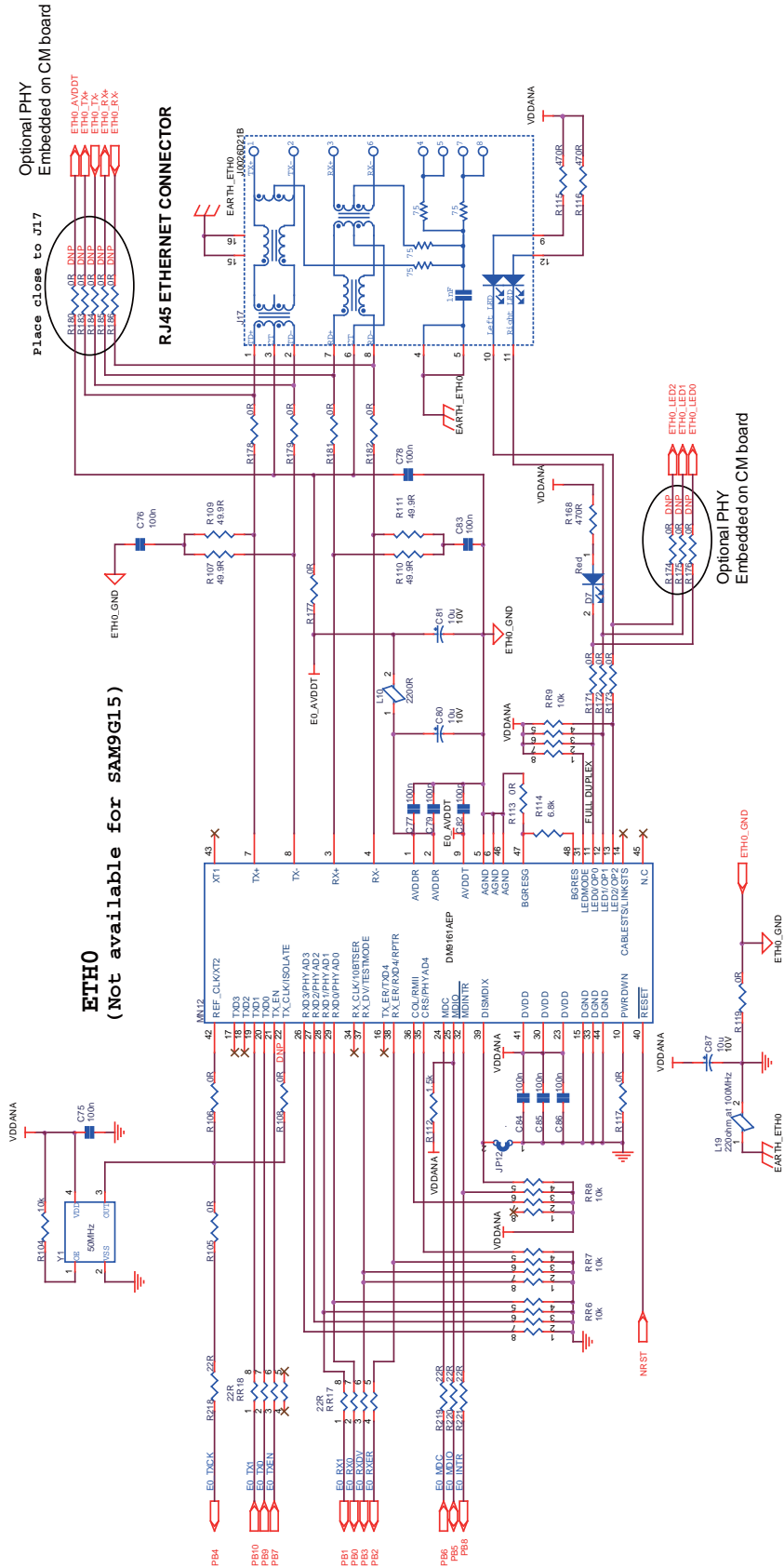

Ethernet 1 is only available for SAM9X25. The PHY on Ethernet 1 is enabled by the SELCONFIG signal from a pull-down resistor on the CM board. Refer to [Section 3.4.1 "DM Board Overview"](#) for detail.

Some pins (PC16, PC20, PC21, PC28, PC26 and PC29) are configured as Ethernet 1 input from PHY for SAM9X25, whereas they are configured as LCD data pins on other processors. An IO buffer MN17 is inserted in series with these signals to prevent the LCD from being disturbed by unknown status of the PHY device.

Figure 3-27. ETH1 Port

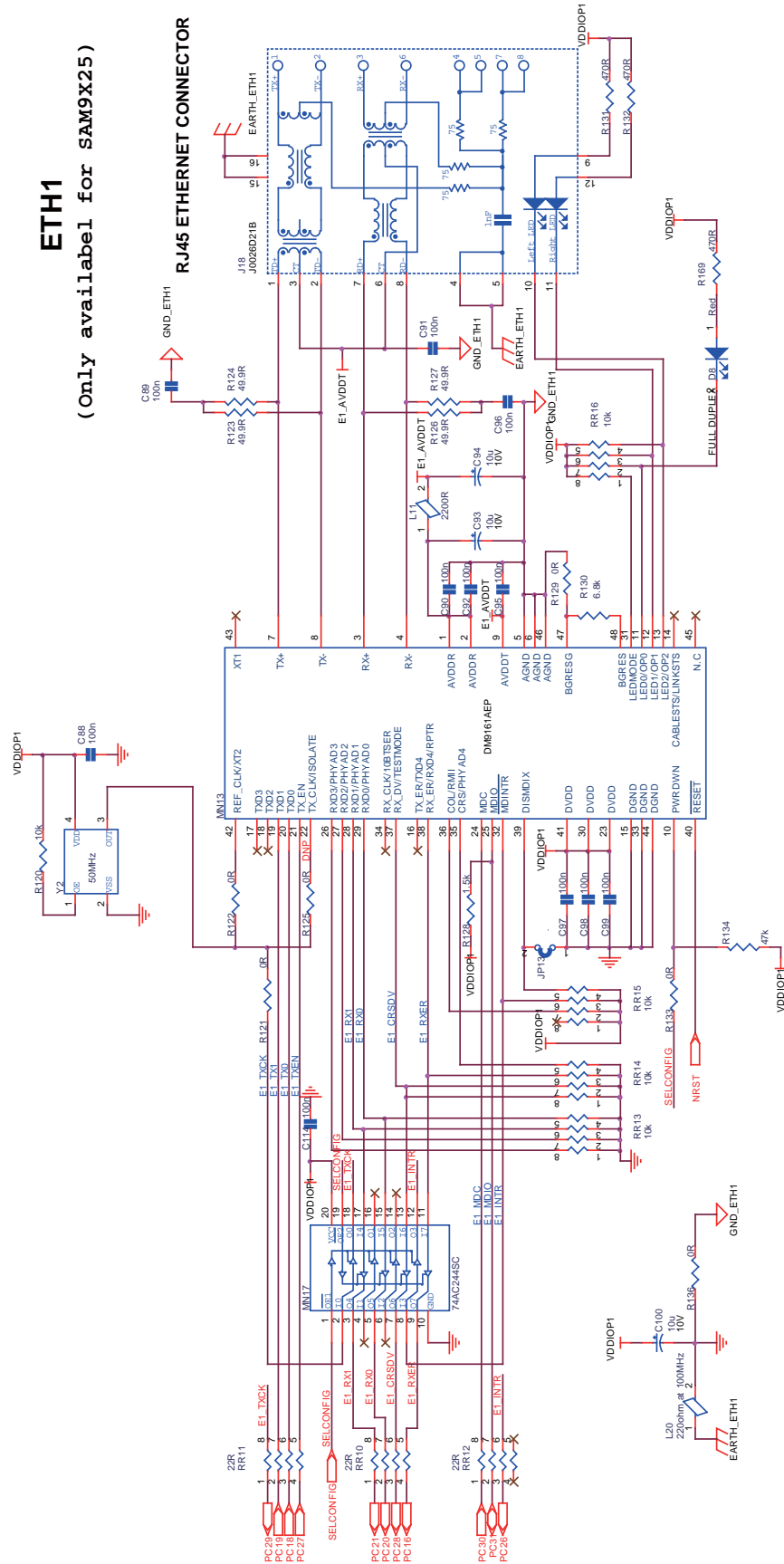

### 3.3.3.8 Audio

The Evaluation Kit includes a WM8731 CODEC for digital sound input and output. This interface includes audio jacks for line audio input (J13) and headphone line output (J15).

The SAM9 processor is configured in IIS slave mode to interface with the WM8731 Codec. The IIS master mode is also possible for evaluation by populating R162/R164 and removing the crystal Y3.

**Figure 3-28. Audio Interface**

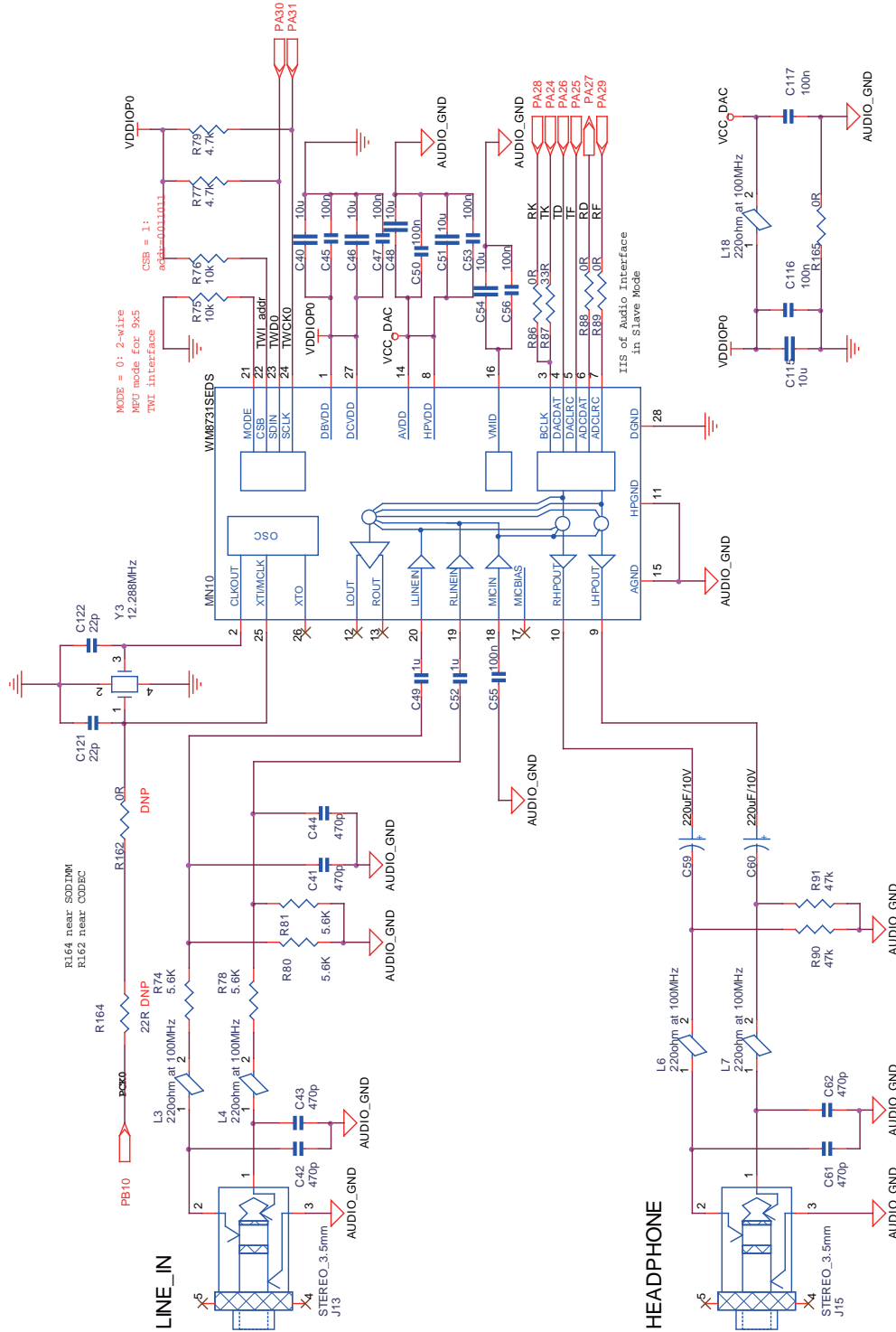



### 3.3.3.9 1-Wire EEPROM

The EK board also features a 1-Wire device acting as a “firmware label” to store information like chip type, manufacturer’s name, production date etc.

**Figure 3-29. 1-Wire on EK**

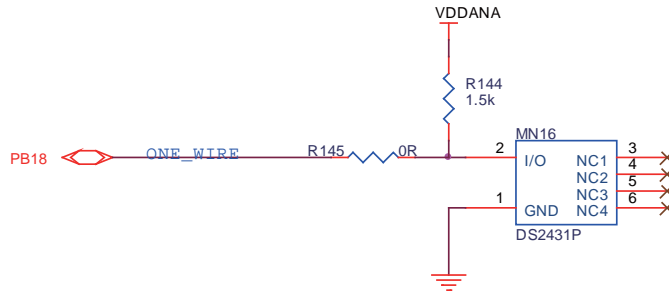

### 3.3.3.10 CAN Bus

Two boards, the SAM9X35-EK and SAM9X25-EK, feature two Controller Area Network (CAN) ports with transceiver.

CAN0 uses the same IOs (PA9, PA10) as the DBGU. A jumper, JP11, is used to select either of the interfaces.

- Open JP11 to select the CAN function.
- Close JP11 to select the DBGU function.

A 3-state output buffer, MN19 is inserted in series with the output channels of the CAN transceiver, which share IOs with the DBGU. This is necessary because the CAN transceiver does not feature 3-state outputs.

**Figure 3-30. CAN on EK**

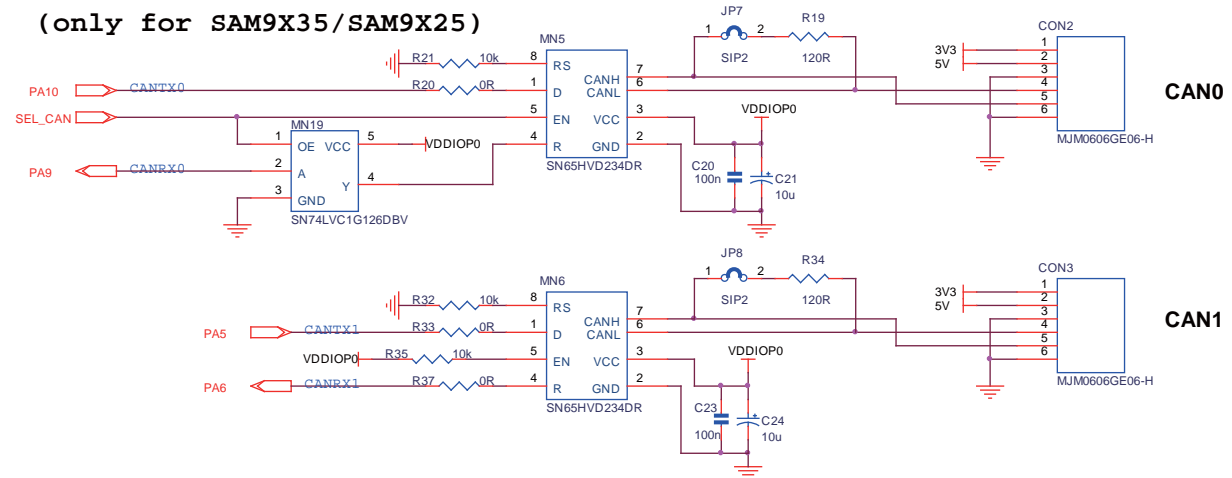

### 3.3.3.11 Telephone Interface

The Evaluation Kit features a smart DAA (Data Access Arrangement) chip to drive an analog telephone line on RJ11 6P4C port (J16).

Figure 3-31. Telephone Interface

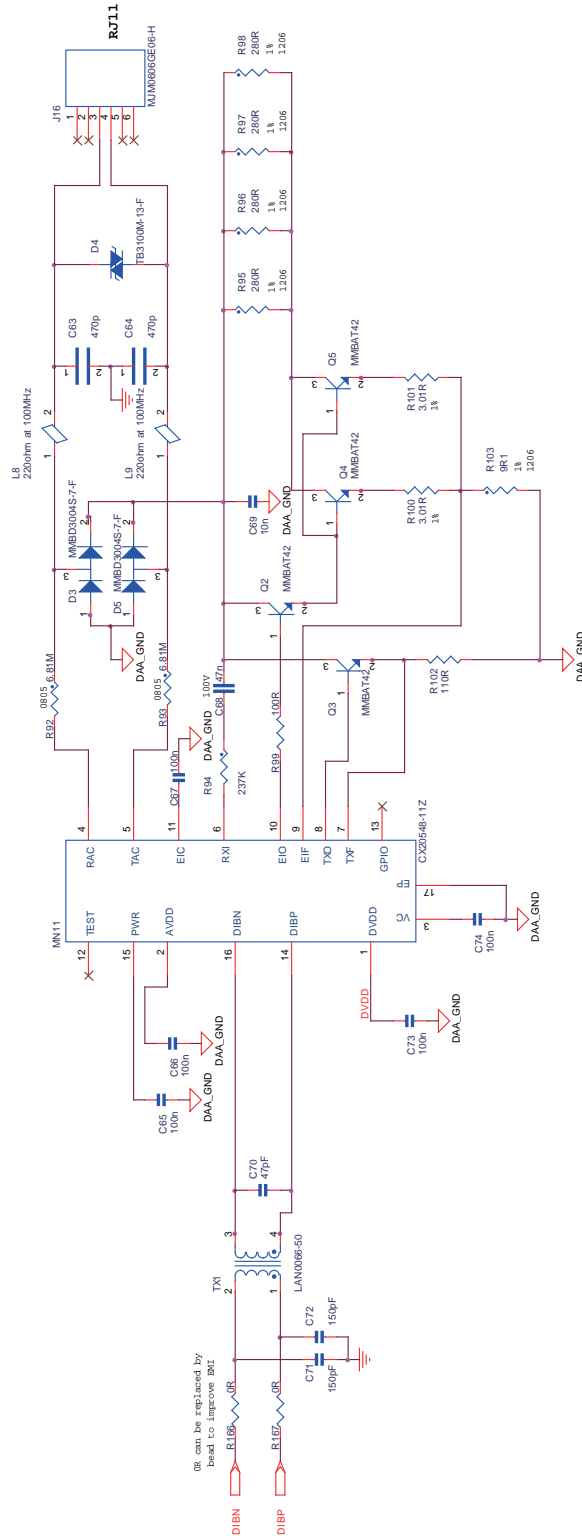

### 3.3.3.12 SD/MMC Interface

The EK board has two high-speed MultiMedia Card Interfaces (MCI). The first interface is used as a 4-bit interface (MCI0), connected to a MicroSD card slot. The second interface is used as a 4-bit interface (MCI1), connected to an SD/MMC card slot.

The memory card is not included in the Evaluation Kit.

Please note that the power is connected to VCC, which is 3.3 volts.

**Figure 3-32. SD/MMC Interface**

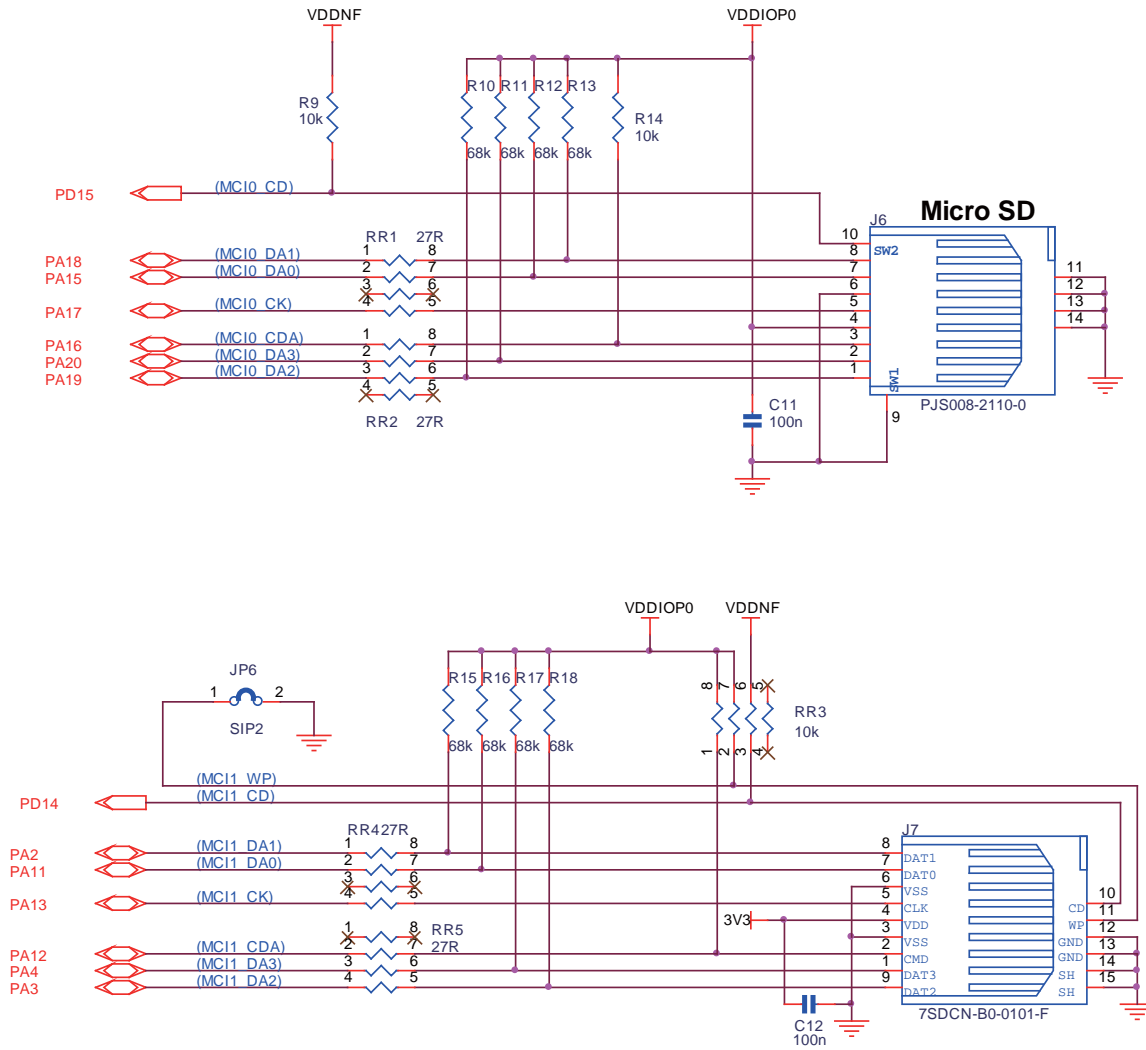

### 3.3.3.13 ZigBee

The EK board has a 10-pin male connector for the Atmel RZ600 ZigBee module.

DNP 0 Ohm resistors have been implemented in series with the PIO lines that are used elsewhere in the design. Thereby, enable their individual disconnections, should a conflict occur in user application.

**Figure 3-33. ZigBee Interface**

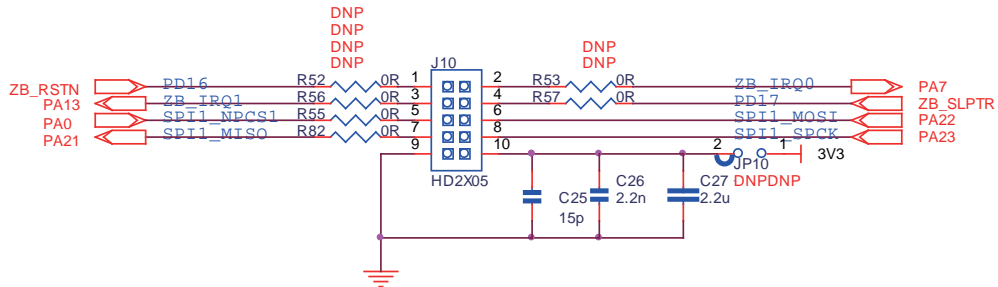

### 3.3.3.14 LED Indicators

The EK board has three LED indicators for purposes shown below:

**Table 3-8. LED Indicators**

Reference	Color	Function
D2	Red	3v3 Power indicator
D7	Red	ETH0 Full Duplex
D8	Red	ETH1 Full Duplex

Refer to [Section 3.3.3.2 "Power Supplies"](#) and [Section 3.3.3.7 "Ethernet 10/100 \(EMAC\) Port"](#) for details.

### 3.3.3.15 Expansion Ports

Most GPIOs are routed to expansion ports J1, J2, J3.

All I/Os of the MPU Image Sensor Interface (ISI) are routed to connectors J21.

The LCD and touch screen interfaces are routed to connectors J21, J22.

**Figure 3-34. I/O Expansion**

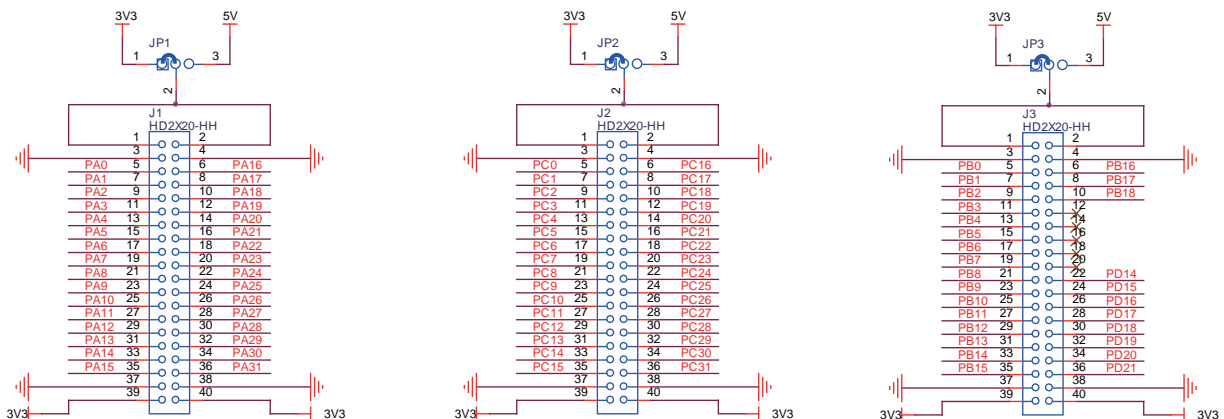

**Figure 3-35. LCD and ISI Expansion**

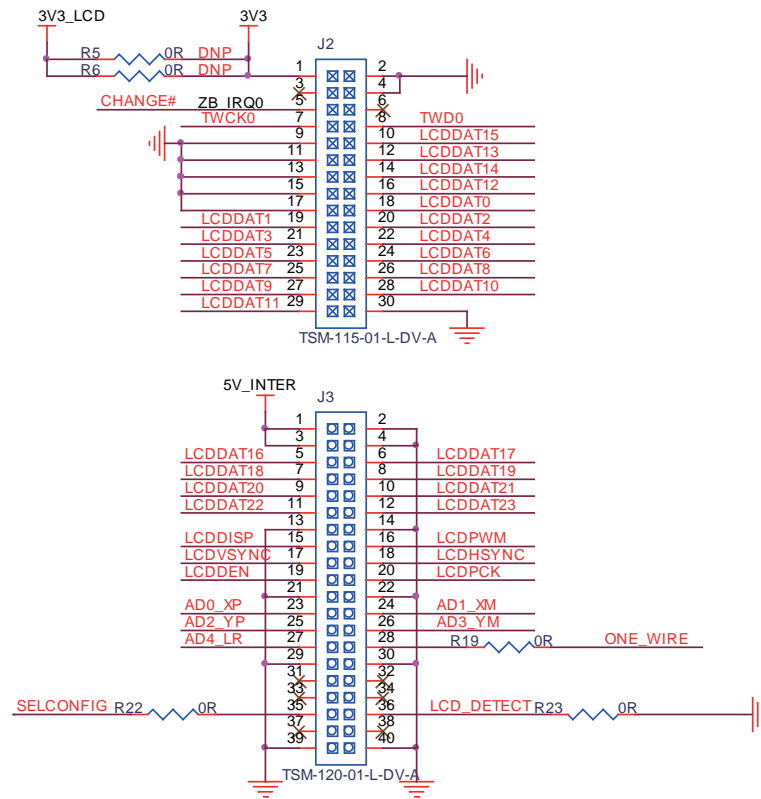

### 3.3.4 Configuration

This section describes the PIO usage, the jumpers, the test points and the solder drops of the EK board.

#### 3.3.4.1 JTAG/ICE Configuration

**Table 3-9. JTAG/ICE**

Designation	Default Setting	Feature
R50	Not Populated	Disables the ICE NTRST input
R51	Populated	Enables the ICE RTCK return. R94 must be opened
R54	Populated	Enables the ICE NRST input
R58	Not Populated	Disables TCK <-> RTCK local loop

#### 3.3.4.2 Boot Mode Select Configuration

**Table 3-10. BMS**

Designation	Default Setting	Feature
JP9	Open	Default to boot on embedded ROM Close to boot on external memory

### 3.3.4.3 Force Power ON Configuration

**Table 3-11. Force Power ON**

Designation	Default Setting	Feature
JP5	Close	Keep on-board regulator always on Open to feature SHDN function

### 3.3.4.4 White Protection Configuration on MC11

**Table 3-12. Write Protection on MC11**

Designation	Default Setting	Feature
JP6	Close	MC11 write protect selected Open to disable protection

### 3.3.4.5 Selection between DBGU and CAN

**Table 3-13. Select DBGU or CAN**

Designation	Default Setting	Feature
JP11	Close	Default to select DBGU Open to select CAN0

### 3.3.4.6 Codec IIS Configuration

**Table 3-14. Codec IIS**

Designation	Default Setting	Feature
R162, R164	Not Populated	IIS master mode, clock the codec by PCK0
C121, C122, Y3	Populated	IIS slaver mode, clock the codec by external crystal

### 3.3.4.7 ETH0 Configuration

**Table 3-15. ETH0**

Designation	Default Setting	Feature
R180, R183, R184, R185, R185, R186, R174, R175, R176	Not Populated	Populated to select the PHY channel on CM. Channel on EK must be cut if select the PHY on CM.
R177, R178, R179, R181, R182, R218, R171, R172, R173	Populated	Selection of PHY channel on EK

### 3.3.4.8 PIO Usage

**Table 3-16. PIO A Pin Assignment and Signal Description**

Signal	Alternate	Periph A	Periph B	Periph C	Module CM	EK
PA0	–	TXD0	SPI1_NPCS1	–	TXD0/ ZigBee	USART0 shared with ZigBee
PA1	–	RXD0	SPI0_NPCS2	–	RXD0	USART0
PA2	–	RTS0	MCI1_DA1	E0_ETX0	RTS0/ MCI1	USART0 shared with MCI1
PA3	–	CTS0	MCI1_DA2	E0_ETX1	CTS0/ MCI1	USART0 shared with MCI1
PA4	–	SCK0	MCI1_DA3	E0_ETXER	MCI1	–
PA5	–	TXD1	CANTX1	–	CAN1	–
PA6	–	RXD1	CANRX1	–	CAN1	–
PA7	–	TXD2	SPI0_NPCS1	–	–	ZB_IRQ0
PA8	–	RXD2	SPI1_NPCS0	–	–	Serial Flash
PA9	–	–	CANRX0	–	DBGU+CAN0	DBGU shared with CAN0
PA10	–	–	CANTX0	–	DBGU+CAN0	DBGU shared with CAN0
PA11	–	SPI0_MISO	MCI1_DA0	–	MCI1	–
PA12	–	SPI0_MOSI	MCI1_CDA	–	MCI1	–
PA13	–	SPI0_SPCK	MCI1_CK	–	MCI1	ZB_IRQ1
PA14	–	SPI0_NPCS0	–	–	–	MCI0
PA15	–	MCI0_DA0	–	–	–	MCI0
PA16	–	MCI0_CDA	–	–	–	MCI0
PA17	–	MCI0_CK	–	–	–	MCI0
PA18	–	MCI0_DA1	–	–	–	MCI0
PA19	–	MCI0_DA2	–	–	–	MCI0
PA20	–	MCI0_DA3	–	–	–	Serial Flash
PA21	–	TIOA0	SPI1_MISO	–	ZigBee	Serial Flash
PA22	–	TIOA1	SPI1_MOSI	–	ZigBee	Serial Flash
PA23	–	TIOA2	SPI1_SPCK	–	ZigBee	SSC
PA24	–	TCLK0	TK	–	–	SSC
PA25	–	TCLK1	TF	–	–	SSC
PA26	–	TCLK2	TD	–	–	SSC
PA27	–	TIOB0	RD	–	–	SSC
PA28	–	TIOB1	RK	–	–	SSC
PA29	–	TIOB2	RF	–	–	SSC
PA30	–	TWD0	SPI1_NPCS3	E0_EMDC	–	TWD0
PA31	–	TWCK0	SPI1_NPCS2	E0_ETXEN	–	TWCK0

**Table 3-17. PIO B Pin Assignment and Signal Description**

Signal	Alternate	Periph A	Periph B	Periph C	Module CM	EK
PB0	–	E0_RX0	RTS2	–	ETH0	–
PB1	–	E0_RX1	CTS2	–	ETH0	–
PB2	–	E0_RXER	SCK2	–	ETH0	–
PB3	–	E0_RXDV	SPI0_NPCS3	–	ETH0	–
PB4	–	E0_TXCK	TWD2	–	ETH0	–
PB5	–	E0_MDIO	TWCK2	–	ETH0	–
PB6	AD7	E0_MDC	–	–	ETH0	–
PB7	AD8	E0_TXEN	–	–	ETH0	–
PB8	AD9	E0_TXER	–	–	ETH0_INTR	–
PB9	AD10	E0_TX0	PCK1	–	ETH0	–
PB10	AD11	E0_TX1	PCK0	–	ETH0	–
PB11	AD0xp	E0_TX2	PWM0	–	–	TSC
PB12	AD1xm	E0_TX3	PWM1	–	–	TSC
PB13	AD2yp	E0_RX2	PWM2	–	–	TSC
PB14	AD3ym	E0_RX3	PWM3	–	–	TSC
PB15	AD4lr	E0_RXCK	–	–	–	TSC
PB16	AD5	E0_CRD	–	–	–	VBUS_SENSE (USB)
PB17	AD6	E0_COL	–	–	–	OVCUR_USB (Open drain)
PB18		IRQ	ADTRG	–	USER_LED1#	ONE_WIRE



**Table 3-18. PIO C Pin Assignment and Signal Description**

Signal	Alternate	Periph A	Periph B	Periph C	Module CM	EK f (LCD)	EK f (ISI+IO)
PC0	–	LCDDAT0	ISI_D0	TWD1	–	LCDDAT0	ISI_D0
PC1	–	LCDDAT1	ISI_D1	TWCK1	–	LCDDAT1	ISI_D1
PC2	–	LCDDAT2	ISI_D2	TIOA3	–	LCDDAT2	ISI_D2
PC3	–	LCDDAT3	ISI_D3	TIOB3	–	LCDDAT3	ISI_D3
PC4	–	LCDDAT4	ISI_D4	TCLK3	–	LCDDAT4	ISI_D4
PC5	–	LCDDAT5	ISI_D5	TIOA4	–	LCDDAT5	ISI_D5
PC6	–	LCDDAT6	ISI_D6	TIOB4	–	LCDDAT6	ISI_D6
PC7	–	LCDDAT7	ISI_D7	TCLK4	–	LCDDAT7	ISI_D7
PC8	–	LCDDAT8	ISI_D8	UTXD0	–	LCDDAT8	ISI_D8
PC9	–	LCDDAT9	ISI_D9	URXD0	–	LCDDAT9	ISI_D9
PC10	–	LCDDAT10	ISI_D10	PWM0	–	LCDDAT10	ISI_D10
PC11	–	LCDDAT11	ISI_D11	PWM1	–	LCDDAT11	ISI_D11
PC12	–	LCDDAT12	ISI_PCK	TIOA5	–	LCDDAT12	ISI_PCK
PC13	–	LCDDAT13	ISI_VSYNC	TIOB5	–	LCDDAT13	ISI_VSYNC
PC14	–	LCDDAT14	ISI_HSYNC	TCLK5	–	LCDDAT14	ISI_HSYNC
PC15	–	LCDDAT15	ISI_MCK	PCK0	SSC	LCDDAT15	ISI_MCK/PCK0
PC16	–	LCDDAT16	E1_RXER	UTXD1	–	LCDDAT16	E1_RXER
PC17	–	LCDDAT17	–	URXD1	–	LCDDAT17	–
PC18	–	LCDDAT18	E1_TX0	PWM0	–	LCDDAT18	E1_TX0
PC19	–	LCDDAT19	E1_TX1	PWM1	–	LCDDAT19	E1_TX1
PC20	–	LCDDAT20	E1_RX0	PWM2	–	LCDDAT20	E1_RX0
PC21	–	LCDDAT21	E1_RX1	PWM3	–	LCDDAT21	E1_RX1
PC22	–	LCDDAT22	TXD3	–	–	LCDDAT22	TXD3
PC23	–	LCDDAT23	RXD3	–	–	LCDDAT23	RXD3
PC24	–	LCDDISP	RTS3	–	–	LCDDISP	RTS3
PC25	–	–	CTS3	–	–	–	CTS3
PC26	–	LCDPWM	SCK3	–	Eth1_Intr1	LCDPWM	–
PC27	–	LCDVSYNC	E1_TXEN	RTS1	–	LCDVSYNC	E1_TXEN
PC28	–	LCDHSYNC	E1_CRSDV	CTS1	–	LCDHSYNC	E1_CRSDV
PC29	–	LCDDEN	E1_TXCK	SCK1	–	LCDDEN	E1_TXCK
PC30	–	LCDPCK	E1_MDC	–	–	LCDPCK	E1_MDC
PC31	–	FIQ	E1_MDIO	PCK1	–	–	E1_MDIO

**Table 3-19. PIO D Pin Assignment and Signal Description**

Signal	Alternate	Periph A	Periph B	Periph C	Module CM	EK
PD0	–	NANDOE	–	–	Nand Flash	–
PD1	–	NANDWE	–	–	Nand Flash	–
PD2	–	A21/NANDALE	–	–	Nand Flash	–
PD3	–	A22/NANDCLE	–	–	Nand Flash	–
PD4	–	NCS3	–	–	CS NAND Flash	–
PD5	–	NWAIT	–	–	NAND_RD/BY	–
PD6	–	D16	–	–	Nand Flash	–
PD7	–	D17	–	–	Nand Flash	–
PD8	–	D18	–	–	Nand Flash	–
PD9	–	D19	–	–	Nand Flash	–
PD10	–	D20	–	–	Nand Flash	MCI0_CD (switch)
PD11	–	D21	–	–	Nand Flash	MCI1_CD (switch)
PD12	–	D22	–	–	Nand Flash	ZB_RSTN
PD13	–	D23	–	–	Nand Flash	ZB_SLPTR
PD14	–	D24	–	–	–	EN5V_HDA#
PD15	–	D25	A20	–	–	EN5V_HDB#
PD16	–	D26	A23	–	–	EN5V_HDC#
PD17	–	D27	A24	–	–	–
PD18	–	D28	A25	–	–	–
PD19	–	D29	NCS2	–	–	–
PD20	–	D30	NCS4	–	–	–
PD21	–	D31	NCS5	–	POWR_LED	–

### 3.3.5 Connectors

#### 3.3.5.1 Power Supply

Figure 3-36. Power Supply Connector J4

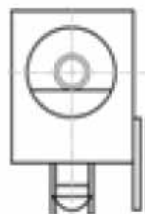

Table 3-20. Power Supply Connector J2 Signal Description

Pin	Mnemonic	Signal description
1	Center	+5V
2	–	GND
3	–	Floating

#### 3.3.5.2 SODIMM Card Edge Socket

The Evaluation Kit uses a SODIMM200 standard connector for CM board interfacing.

Please note that this is not an industry standard pin-out and that it is unlikely to be compatible with off-the-shelf SODIMM cards.

Figure 3-37. SODIMM200 Socket CON1



Table 3-21. SODIMM200 CON1 Signal Descriptions

Function	Type	x5 pad name	SODIMM 200			x5 pad name	Type	Function
		Front Side	A	–	B	Back Side		
VCC 3V3	–	POWER OUTPUT	1	–	2	POWER OUTPUT	–	VCC 3V3
VCC 3V3	–	POWER OUTPUT	3	–	4	POWER OUTPUT	–	VCC 3V3
GND	–	–	5	–	6	POWER OUTPUT	VBAT	–
USBC_DP	I/O	USB Data Positive	7	–	8	–	SYSC	JTAGSEL
USBC_DM	I/O	USB Data Negative	9	–	10	–	SYSC	WKUP
GND	–	–	11	–	12	–	SYSC	SHDN
USBB_DM	I/O	USB Data Negative	13	–	14	–	SYSC	BMS
USBB_DP	I/O	USB Data Positive	15	–	16	–	SYSC	nRST

**Table 3-21. SODIMM200 CON1 Signal Descriptions (Continued)**

Function	Type	x5 pad name	SODIMM 200			x5 pad name	Type	Function
GND	–	–	17	–	18	–	SYSC	nTRST
DIBP	I/O	–	19	–	20	–	RSTJTAG	TDI
DIBN	I/O	–	21	–	22	–	RSTJTAG	TCK
GND	–	–	23	–	24	–	RSTJTAG	TMS
USBA_DM	I/O	USB Data Negative	25	–	26	–	RSTJTAG	TDO
USBA_DP	I/O	USB Data Positive	27	–	28	–	RSTJTAG	RTCK
GND	–	–	29	–	30	–	–	PWR_EN
RFU	–	RFU	31	–	32	RFU	–	RFU
RFU	–	RFU	33	–	34	RFU	–	RFU
RFU	–	RFU	35	–	36	RFU	–	RFU
RFU	–	RFU	37	–	38	RFU	–	RFU
RFU	–	RFU	39	–	40	RFU	–	RFU
KEY								
GND	–	–	41	–	42	–	–	GND
RFU	–	RFU	43	–	44	RFU	–	RFU
RFU	–	RFU	45	–	46	RFU	–	RFU
RFU	–	RFU	47	–	48	RFU	–	RFU
RFU	–	RFU	49	–	50	RFU	–	RFU
GND	–	–	51	–	52	–	–	GND
RFU	–	RFU	53	–	54	RFU	–	RFU
RFU	–	RFU	55	–	56	RFU	–	RFU
RFU	–	RFU	57	–	58	RFU	–	RFU
RFU	–	RFU	59	–	60	RFU	–	RFU
VDDNF	POWER DOMAIN FROM CM		61	–	62	POWER DOMAIN FROM CM		VDDNF
PD0	GPIO D	NANDOE	63	–	64	NANDWE	GPIO D	PD1
PD2	GPIO D	A21/NANDALE	65	–	66	A22/NANDCLE	GPIO D	PD3
PD4	GPIO D	NCS3	67	–	68	NWAIT	GPIO D	PD5
PD6	GPIO D	D16	69	–	70	D17	GPIO D	PD7
PD8	GPIO D	D18	71	–	72	D19	GPIO D	PD9
GND	–	–	73	–	74	–	–	GND
PD10	GPIO D	D20	75	–	76	D21	GPIO D	PD11
PD12	GPIO D	D22	77	–	78	D23	GPIO D	PD13
PD14	GPIO D	D24	79	–	80	D25/A20	GPIO D	PD15
PD16	GPIO D	D26/A23	81	–	82	D27/A24	GPIO D	PD17
PD18	GPIO D	D28/A25	83	–	84	D29/NCS2	GPIO D	PD19
PD20	GPIO D	D30/NCS4	85	–	86	D31/NCS5	GPIO D	PD21
VDDIOP0	POWER OUTPUT		87	–	88	POWER OUTPUT		VDDIOP0

**Table 3-21. SODIMM200 CON1 Signal Descriptions (Continued)**

Function	Type	x5 pad name	SODIMM 200			x5 pad name	Type	Function
PA0	GPIO A	TXD0/SPI1-NPCS1	89	–	90	RXD0/SPI0-NPCS2	GPIO A	PA1
PA2	GPIO A	MCI1_DA1/E0_ETX0	91	–	92	CTS0/ MCI1_DA2/ E0_ETX1	GPIO A	PA3
PA4	GPIO A	SCK0/MCI1_DA3/ E0_ETXER	93	–	94	–	–	GND
PA11	GPIO A	SPI0_MISO/ MCI1_DA0	95	–	96	SPI0_MOSI/ MCI1_CDA	GPIO A	PA12
PA13	GPIO A	SPI0_SPCK/ MCI1_CK	97	–	98	SPI0_NPCS0	GPIO A	PA14
GND	–	–	99	–	100	TXD2/ SPI0_NPCS1	GPIO A	PA7
PA8	GPIO A	RXD2/SPI1_NPCS0	101	–	102	TIOA0 /SPI1_MISO	GPIO A	PA21
PA22	GPIO A	TIOA1/SPI1_MOS1	103	–	104	TIOA2/ SPI1_SPCK	GPIO A	PA23
PA31	GPIO A	TWCK0/SPI1_NPCS 2/E0_ETXEN	105	–	106	TWD0/ SPI1_NPCS3/ E0_EMDC	GPIO A	PA30
GND	–	–	107	–	108	MCI0_DA0	GPIO A	PA15
PA16	GPIO A	MCI0_CDA	109	–	110	MCI0_CK	GPIO A	PA17
PA18	GPIO A	MCI0_DA1	111	–	112	MCI0_DA2	GPIO A	PA19
PA20	GPIO A	MCI0_DA3	113	–	114	–	–	GND
PA5	GPIO A	TXD1/CANTX1	115	–	116	RXD1/CANRX1	GPIO A	PA6
PA10	GPIO A	DTXD/CANTX0	117	–	118	DRXD/CANRX0	GPIO A	PA9
GND	–	–	119	–	120	TCLK0/TK	GPIO A	PA24
PA25	GPIO A	TCLK1/TF	121	–	122	TCLK2/TD	GPIO A	PA26
PA27	GPIO A	TIOB0/RD	123	–	124	TIOB1/RK	GPIO A	PA28
PA29	GPIO A	TIOB2/RF	125	–	126	–	–	GND
VDDIOP1	POWER OUTPUT		127	–	128	POWER OUTPUT		VDDIOP1
PC0	GPIO C	LCDDAT0/ISI_D0	129	–	130	LCDDAT1	GPIO C	PC1
PC2	GPIO C	LCDDAT2/ISI_D2	131	–	132	LCDDAT3	GPIO C	PC3
PC4	GPIO C	LCDDAT4	133	–	134	LCDDAT5	GPIO C	PC5
GND	–	–	135	–	136	LCDDAT6	GPIO C	PC6
PC7	GPIO C	LCDDAT7	137	–	138	LCDDAT8	GPIO C	PC8
PC9	GPIO C	LCDDAT9	139	–	140	LCDDAT10	GPIO C	PC10
PC11	GPIO C	LCDDAT11	141	–	142	–	–	GND
PC12	GPIO C	LCDDAT12	143	–	144	LCDDAT13	GPIO C	PC13
PC14	GPIO C	LCDDAT14	145	–	146	LCDDAT15	GPIO C	PC15
GND	–	–	147	–	148	LCDDAT16	GPIO C	PC16
PC17	GPIO C	LCDDAT17	149	–	150	LCDDAT18	GPIO C	PC18
PC19	GPIO C	LCDDAT19	151	–	152	LCDDAT20	GPIO C	PC20

**Table 3-21. SODIMM200 CON1 Signal Descriptions (Continued)**

Function	Type	x5 pad name	SODIMM 200			x5 pad name	Type	Function
PC21	GPIO C	LCDDAT21	153	–	154	–	–	GND
PC22	GPIO C	LCDDAT22	155	–	156	LCDDAT23	GPIO C	PC23
PC24	GPIO C	LCDDISP	157	–	158	–	GPIO C	PC25
PC26	GPIO C	LCDPWM	159	–	160	LCDVSYNC	GPIO C	PC27
GND	–	–	161	–	162	LCDHSYNC	GPIO C	PC28
PC29	GPIO C	LCDDEN	163	–	164	E1_MDC	GPIO C	PC30
PC31	GPIO C	E1_MDIO	165	–	166	–	–	SELCONFIG
VDDANA	POWER OUTPUT		167	–	168	POWER OUTPUT		VDDANA
PB0	GPIO B	E0_RX0	169	–	170	E0_RX1	GPIO B	PB1
PB2	GPIO B	E0_RXER	171	–	172	E0_RXDV	GPIO B	PB3
PB4	GPIO B	E0_TXCK	173	–	174	E0_MDIO	GPIO B	PB5
PB6	GPIO B	E0_MDC	175	–	176	E0_TXEN	GPIO B	PB7
PB8	GPIO B	E0_TXER	177	–	178	GNDANA	–	–
PB9	GPIO B	E0_TX0	179	–	180	E0_TX1	GPIO B	PB10
PB11	GPIO B	E0_TX2	181	–	182	E0_TX3	GPIO B	PB12
PB13	GPIO B	E0_RX2	183	–	184	E0_RX3	GPIO B	PB14
PB15	GPIO B	E0_RXCK	185	–	186	E0_CRS	GPIO B	PB16
PB17	GPIO B	E0_COL	187	–	188	GNDANA	–	–
PB18	GPIO B	IRQ	189	–	190	POWER OUTPUT		POWR_REF
GND	–	–	191	–	192	–	ETH	LED0
ETH0_TX+	ETH	–	193	–	194	–	ETH	LED1
ETH0_TX-	ETH	–	195	–	196	–	ETH	LED2
ETH0_RX+	ETH	–	197	–	198	–	ETH	AVDDT
ETH0_RX-	ETH	–	199	–	200	–	–	GND_ETH

### 3.3.5.3 JTAG/ICE Connector

Figure 3-38. JTAG J9

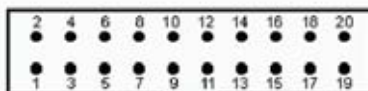

Table 3-22. JTAG/ICE Connector J13 Signal Descriptions

Pin	Mnemonic	Description
1	VTref. 3.3V power	This is the target reference voltage. It is used to check if the target has power, to create the logic-level reference for the input comparators, and to control the output logic levels to the target. It is normally fed from VDD on the target board and must not have a series resistor.
2	Vsupply. 3.3V power	This pin is not connected in SAM-ICE. It is reserved for compatibility with other equipment. Connect to VDD or leave open in target system.
3	nTRST TARGET RESET - Active-low output signal that resets the target	JTAG Reset. Output from SAM-ICE to the Reset signal on the target JTAG port. Typically connected to nTRST on the target CPU. This pin is normally pulled HIGH on the target to avoid unintentional resets when there is no connection.
4	GND	Common ground
5	TDI TEST DATA INPUT - Serial data output line, sampled on the rising edge of the TCK signal.	JTAG data input of target CPU. It is recommended that this pin is pulled to a defined state on the target board. Typically connected to TDI on target CPU.
6	GND	Common ground
7	TMS TEST MODE SELECT	JTAG mode set input of target CPU. This pin should be pulled up on the target. Typically connected to TMS on target CPU. Output signal that sequences the target's JTAG state machine, sampled on the rising edge of the TCK signal.
8	GND	Common ground
9	TCK TEST CLOCK - Output timing signal, for synchronizing test logic and control register access.	JTAG clock signal to target CPU. It is recommended that this pin is pulled to a defined state on the target board. Typically connected to TCK on target CPU.
10	GND	Common ground
11	RTCK - Input Return test clock signal from the target.	Some targets must synchronize the JTAG inputs to internal clocks. To assist in meeting this requirement, a returned and retimed TCK can be used to dynamically control the TCK rate. SAM-ICE supports adaptive clocking which waits for TCK changes to be echoed correctly before making further changes. Connect to RTCK if available, otherwise to GND.
12	GND	Common ground
13	TDO JTAG TEST DATA OUTPUT - Serial data input from the target.	JTAG data output from target CPU. Typically connected to TDO on target CPU.
14	GND	Common ground
15	nSRST RESET	Active-low reset signal. Target CPU reset signal.
16	GND	Common ground
17	RFU	This pin is not connected in SAM-ICE.

**Table 3-22. JTAG/ICE Connector J13 Signal Descriptions (Continued)**

Pin	Mnemonic	Description
18	GND	Common ground
19	RFU	This pin is not connected in SAM-ICE.
20	GND	Common ground

### 3.3.5.4 USB Type A Dual Port

**Figure 3-39. USB Type A Dual Port J19**

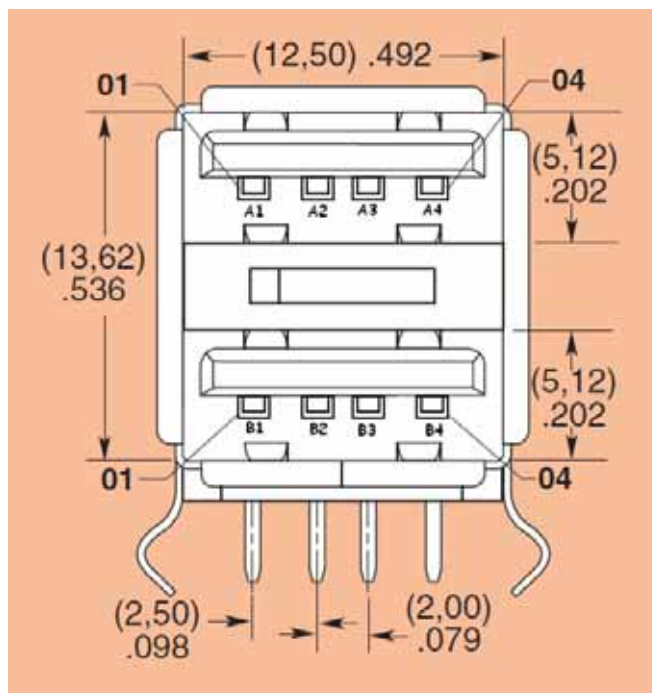

**Table 3-23. USB Type A Dual Port J19 Signal Descriptions**

Pin	Mnemonic	Description
A1	Vbus – USB_A	5V power
A2	DM – USB_A	Data minus
A3	DP – USB_A	Data plus
A4	GND	Common ground
B1	Vbus – USB_A	5V power
B2	DM – USB_A	Data minus
B3	DP – USB_A	Data plus
B4	GND	Common ground
Mechanical pins		Shield



### 3.3.5.5 USB Micro AB

Figure 3-40. USB Host/Device Micro AB Connector J20



Table 3-24. USB Host/Device Micro AB Connector J20 Signal Descriptions

Pin	Mnemonic	Description
1	Vbus	5v power
2	DM	Data minus
3	DP	Data plus
4	ID	On the Go Identification
5	GND	Common ground

### 3.3.5.6 DBGU

Figure 3-41. DBGU Connector J11

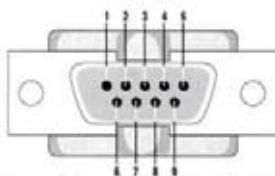

Table 3-25. DBGU Connector J11 Signal Descriptions

Pin	Mnemonic	Description
1, 4, 6, 9	–	NO CONNECTION
2	RXD (RECEIVED DATA)	RS232 serial data output signal
3	TXD (TRANSMITTED Data)	RS232 serial data input signal
5	GND	Common ground
7	RTS (REQUEST TO SEND)	NO USED
8	CTS (CLEAR TO SEND)	NO USED
Mechanical pins	–	Shield

### 3.3.5.7 RS232 Connector with RTS/CTS Handshake Support

Figure 3-42. USART Connector J12, J13

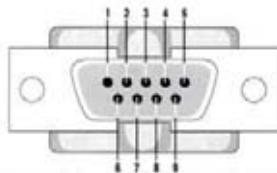

Table 3-26. USART Connector J12 Signal Descriptions

Pin	Mnemonic	PIO	Description
1, 4, 6, 9	–	–	NO CONNECTION
2	RXD (RECEIVED DATA)	PA1	RS232 serial data output signal
3	TXD (TRANSMITTED Data)	PA0	RS232 serial data input signal
5	GND	–	Common ground
7	RTS (REQUEST TO SEND)	PA2	Active-positive RS232 input signal
8	CTS (CLEAR TO SEND)	PA3	Active-positive RS232 output signal
Mechanical pins	–	–	Shield

Table 3-27. USART Connector J13 Signal Descriptions

Pin	Mnemonic	PIO	Description
1, 4, 6, 9	–	–	NO CONNECTION
2	RXD (RECEIVED DATA)	PC23	RS232 serial data output signal
3	TXD (TRANSMITTED Data)	PC22	RS232 serial data input signal
5	GND	–	Common ground
7	RTS (REQUEST TO SEND)	PC24	Active-positive RS232 input signal
8	CTS (CLEAR TO SEND)	PC25	Active-positive RS232 output signal
Mechanical pins	–	–	Shield

### 3.3.5.8 DAA RJ11 Socket (6P4C)

Figure 3-43. DAA RJ11 Socket J16

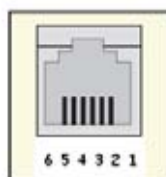

Table 3-28. DAA RJ11 Socket J16 Signal Descriptions

Pin	Mnemonic	Description
1, 2, 5, 6	–	NO CONNECTION
3	RAC	RING side of ordinary telephone line
4	TAC	TIP side of ordinary telephone line

### 3.3.5.9 CAN RJ12 Socket (6P6C)

Figure 3-44. CAN RJ12 Socket CON2, CON3

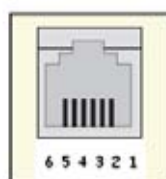

Table 3-29. DAA RJ11 Socket J16 Signal Descriptions

Pin	Mnemonic	Description
1	3V3	POWER PIN
2	5V	POWER PIN
4	CANL	CAN bus differential pair
5	CANH	CAN bus differential pair
4, 6	GND	Common ground

### 3.3.5.10 MicroSD MCI0

Figure 3-45. MicroSD Socket J6

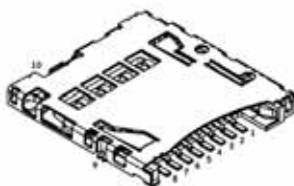

Table 3-30. MicroSD Socket J6 Signal Descriptions

Pin	Mnemonic	Description
1	DAT2	Data Bit 2
2	CD/DAT3	Card Detect/Data Bit 3
3	CMD	Command Line
4	VCC	Supply Voltage 3.3V
5	CLK	Command Line
6	VSS	Common ground
7	DAT0	Data Bit 0
8	DAT1	Data Bit 1
9	SW1	No use, grounded
10	CARD DETECT	CARD DETECT

### 3.3.5.11 SD/MMC MCI1

Figure 3-46. SD/MMC Socket J7



Table 3-31. SD Socket J7 Signal Descriptions

Pin	Mnemonic	PIO	Signal		
			MMC Card	SD Card	
				1-Bit Mode	4-Bit Mode
1	MCI1_DA2	PA3	Not Used	Read Wait (RW)	Data Line DAT2 or Read Wait (RW)
2	MCI1_DA3	PA4	Reserved	Not Used	Data Line DAT3
3	MCI1_CDA	PA12	Command/Response		
4	VDDIOP0		Supply Voltage (3.3-volts) VDDIOP0		
5	MCI1_CK	PA13	Clock		
6	GND		Ground		

**Table 3-31. SD Socket J7 Signal Descriptions (Continued)**

Pin	Mnemonic	PIO	Signal		
			MMC Card	SD Card	
				1-Bit Mode	4-Bit Mode
7	MCI1_DA0	PA11	Data Line DAT0		
8	MC1_DA1	PA2	Not Used	Interrupt (IRQ)	Data Line DAT1 or Interrupt (IRQ)
9	GND		Ground		
10	MCI1_CD	PD14	Card Detect, configured as GPIO, Power domain VDDNF		
11	WP		Write Protect Detect, connects to jumper JP6		
12	GND		Ground		
13	GND		Ground		
14	GND		Ground		
15	GND		Ground		

### 3.3.5.12 Ethernet RJ45 Socket J17, J18

**Figure 3-47. Ethernet RJ45 Socket J17, J18**

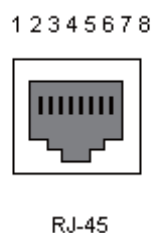

**Table 3-32. DAA RJ11 Socket J16 Signal Descriptions**

Pin	Mnemonic	Description
1	TX+	DIFFERENTIAL OUTPUT PLUS
2	TX-	DIFFERENTIAL OUTPUT MINUS
3	RX+	DIFFERENTIAL INPUT PLUS
4	Reserved	–
5	Reserved	DIFFERENTIAL INPUT MINUS
6	RX-	–
7	Reserved	–
8	Reserved	–

### 3.3.5.13 ZigBee Socket J10

Figure 3-48. ZigBee Socket J10

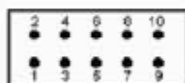

Table 3-33. ZigBee Socket J10 Signal Descriptions

Function	Signal Name	Port	Pin	Pin	Port	Signal Name	Function	Option on misc. port set by OR or solder shunts
Reset	/RST	–	1	2	–	Misc.	–	<ul style="list-style-type: none"> <li>• EEprom for MAC address, cap array settings and serial number</li> <li>• TST: test mode activation</li> <li>• CLKM: RF chip clock output</li> </ul>
Interrupt Request	IRQ	–	3	4	–	SLP_TR	SLP_TR	–
SPI chip select	/SEL	–	5	6	–	MOSI	SPI MOSI	–
SPI MISO	MISO	–	7	8	–	SCLK	SPI CLK	–
Power Supply	GND	GND	9	10	VCC	VCC	VCC	Voltage range: 1.8v to 5.5v, regulated to 3.3v

### 3.3.5.14 LCD/ISI Socket J21

Figure 3-49. LCD/ISI Socket J21

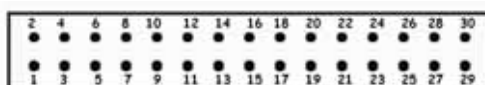

Table 3-34. LCD/ISI Socket J21 Signal Descriptions

LCD	ISI	Pin Num	Pin Num	ISI	LCD
3V3	3V3	1	2	GND	GND
VDDISI	VDDISI	3	4	GND	GND
ZB_IRQ0	ZB_IRQ0	5	6	–	ZB_IRQ1
TWCK0	TWCK0	7	8	–	TWD0
GND	GND	9	10	ISI_MCK	LCDDAT15
GND	GND	11	12	ISI_VSYNC	LCDDAT13
GND	GND	13	14	ISI_HSYNC	LCDDAT14
GND	GND	15	16	ISI_PCK	LCDDAT12
GND	GND	17	18	ISI_D0	LCDDAT0

**Table 3-34. LCD/ISI Socket J21 Signal Descriptions (Continued)**

LCD	ISI	Pin Num	Pin Num	ISI	LCD
LCDDAT1	ISI_D1	19	20	ISI_D2	LCDDAT2
LCDDAT3	ISI_D3	21	22	ISI_D4	LCDDAT4
LCDDAT5	ISI_D5	23	24	ISI_D6	LCDDAT6
LCDDAT7	ISI_D7	25	26	ISI_D8	LCDDAT8
LCDDAT9	ISI_D9	27	28	ISI_D10	LCDDAT10
LCDDAT11	ISI_D11	29	30	GND	GND

### 3.3.5.15 LCD/TSC Socket J22

**Figure 3-50. LCD/TSC Socket J22**

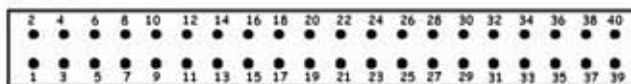

**Table 3-35. LCD/TSC Socket J22 Signal Descriptions**

LCD		Pin Num	Pin Num		LCD
5V	5V_INTER	1	2	GND	GND
5V	5V_INTER	3	4	GND	GND
LCDDAT16	–	5	6	–	LCDDAT17
LCDDAT18	–	7	8	–	LCDDAT19
LCDDAT20	–	9	10	–	LCDDAT21
LCDDAT22	–	11	12	–	LCDDAT23
GND	GND	13	14	GND	GND
LCDDISP	–	15	16	–	LCDPWM
LCDCSYNC	–	17	18	–	LCDHSYNC
LCDDEN	–	19	20	–	LCDPCK
GND	GND	21	22	GND	GND
AD0_XP	TSC	23	24	TSC	AD1_XM
AD2_YP	TSC	25	26	TSC	AD3_YM
AD4_LR	TSC	27	28	–	ONE_WIRE
GND	GND	29	30	GND	GND
SPI1_MISO	–	31	32	–	SPI1_MOSI
SPI1_SPCK	–	33	34	–	SPI1_NPCS1
EN_PWRLCD	SELCONFIG	35	36	LCD_DETECT	LCD_DETECT#
PD16	–	37	38	–	PD17
GND	GND	39	40	GND	GND

### 3.3.5.16 IO Expansion Port J1

Figure 3-51. IO Expansion Socket J1

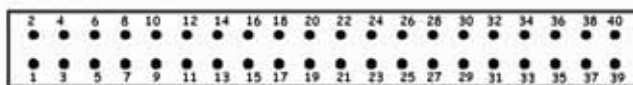

Table 3-36. Expansion Socket J1 Signal Descriptions

PIO	Power	Pin Num	Pin Num	Power	PIO
–	3V3, or 5V	1	2	3V3, or 5V	–
–	GND	3	4	GND	–
PA0	–	5	6	–	PA16
PA1	–	7	8	–	PA17
PA2	–	9	10	–	PA18
PA3	–	11	12	–	PA19
PA4	–	13	14	–	PA20
PA5	–	15	16	–	PA21
PA6	–	17	18	–	PA22
PA7	–	19	20	–	PA23
PA8	–	21	22	–	PA24
PA9	–	23	24	–	PA25
PA10	–	25	26	–	PA26
PA11	–	27	28	–	PA27
PA12	–	29	30	–	PA28
PA13	–	31	32	–	PA29
PA14	–	33	34	–	PA30
PA15	–	35	36	–	PA31
–	GND	37	38	GND	–
–	3V3	39	40	3V3	–



### 3.3.5.17 IO Expansion Port J2

Figure 3-52. IO Expansion Socket J2

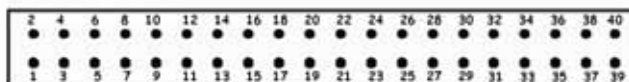

Table 3-37. Expansion Socket J1 Signal Descriptions

PIO	Power	Pin Num	Pin Num	Power	PIO
–	3V3, or 5V	1	2	3V3, or 5V	–
–	GND	3	4	GND	–
PC0	–	5	6	–	PC16
PC1	–	7	8	–	PC17
PC2	–	9	10	–	PC18
PC3	–	11	12	–	PC19
PC4	–	13	14	–	PC20
PC5	–	15	16	–	PC21
PC6	–	17	18	–	PC22
PC7	–	19	20	–	PC23
PC8	–	21	22	–	PC24
PC9	–	23	24	–	PC25
PC10	–	25	26	–	PC26
PC11	–	27	28	–	PC27
PC12	–	29	30	–	PC28
PC13	–	31	32	–	PC29
PC14	–	33	34	–	PC30
PC15	–	35	36	–	PC31
–	GND	37	38	GND	–
–	3V3	39	40	3V3	–

### 3.3.5.18 IO Expansion Port J3

Figure 3-53. IO Expansion Socket J3

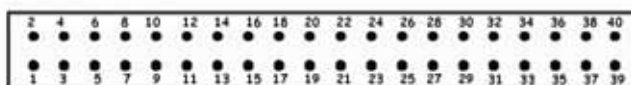
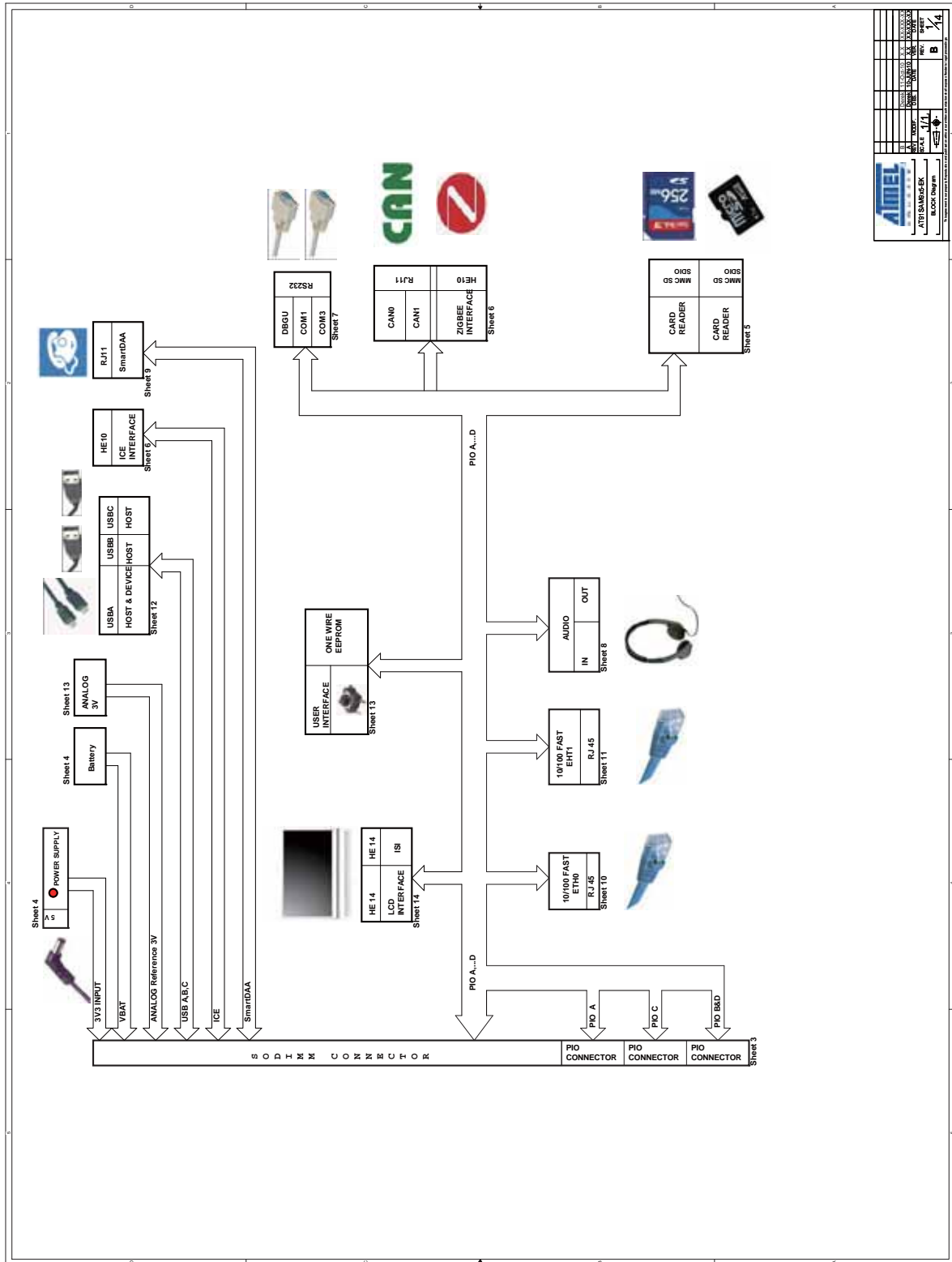

Table 3-38. Expansion Socket J1 Signal Descriptions

PIO	Power	Pin Num	Pin Num	Power	PIO
–	3V3, or 5V	1	2	3V3, or 5V	–
–	GND	3	4	GND	–
PB0	–	5	6	–	PB16
PB1	–	7	8	–	PB17
PB2	–	9	10	–	PB18
PB3	–	11	12	–	–
PB4	–	13	14	–	–
PB5	–	15	16	–	–
PB6	–	17	18	–	–
PB7	–	19	20	–	–
PB8	–	21	22	–	PD14
PB9	–	23	24	–	PD15
PB10	–	25	26	–	PD16
PB11	–	27	28	–	PD17
PB12	–	29	30	–	PD18
PB13	–	31	32	–	PD19
PB14	–	33	34	–	PD20
PB15	–	35	36	–	PD21
–	GND	37	38	GND	–
–	3V3	39	40	3V3	–

### 3.3.6 Schematics

Figure 3-54. EK Board Schematics





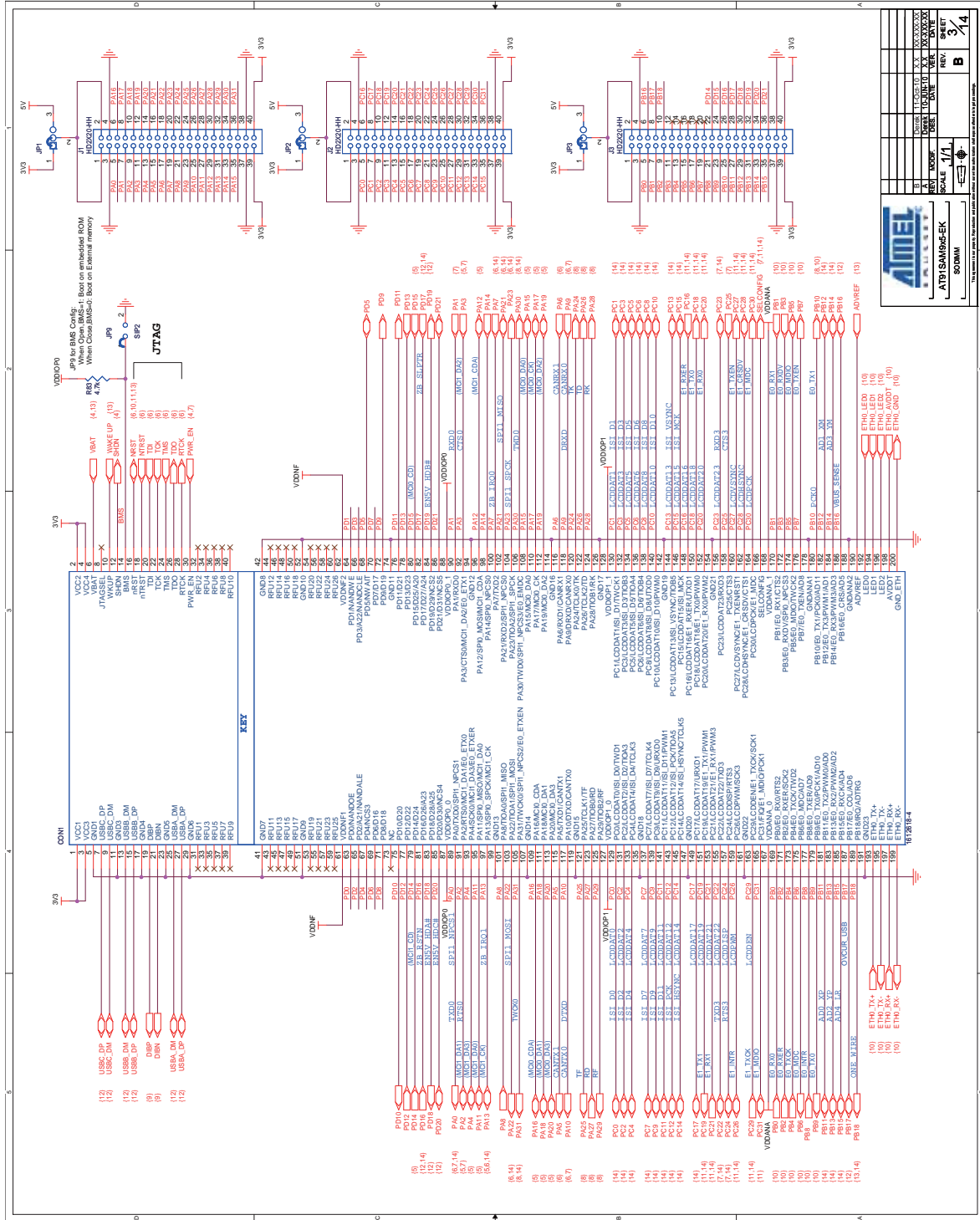

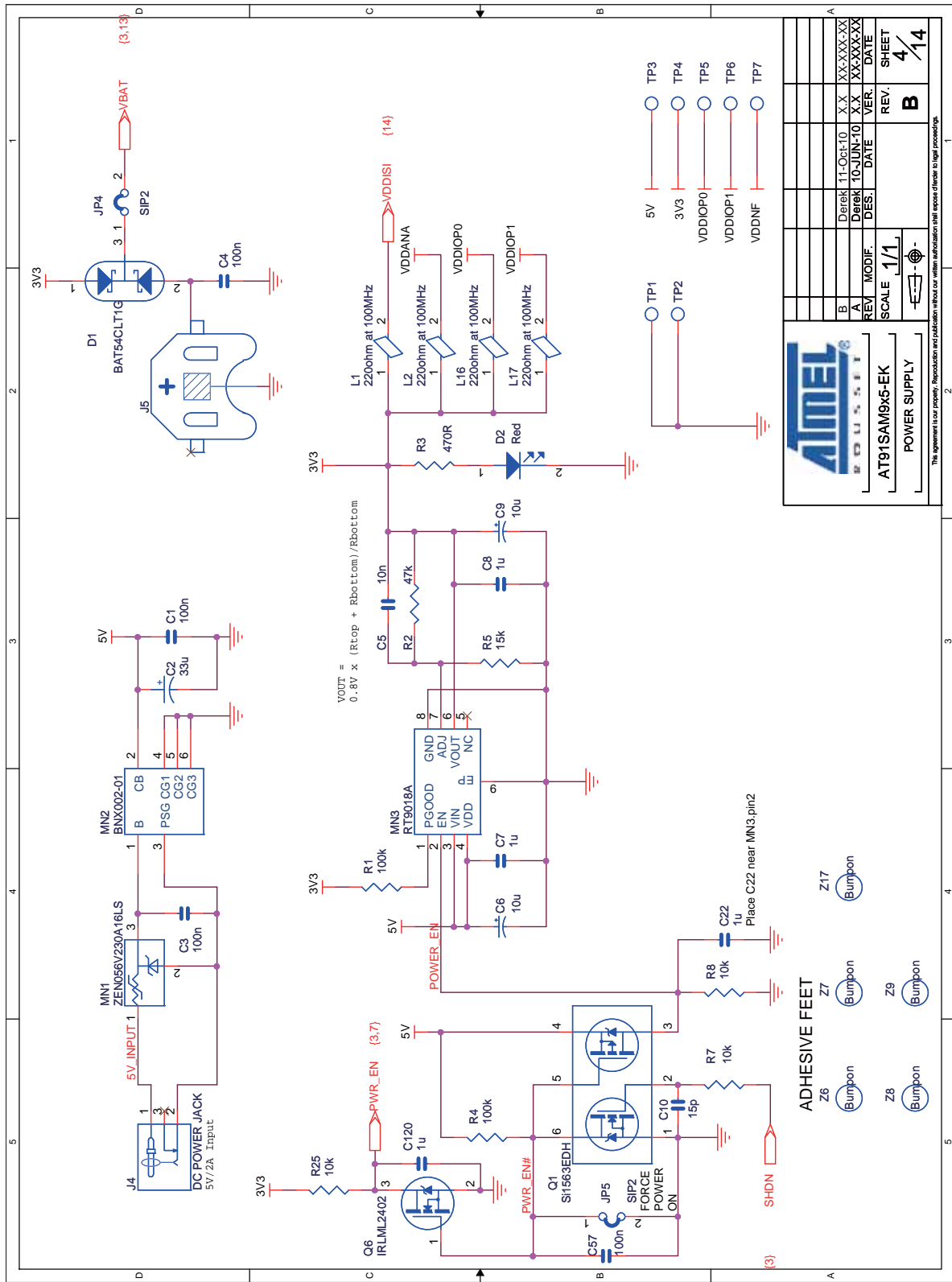

<b>ATMEL</b>		REV. 1/1		SCALE 1/1		POWER SUPPLY	
AT91SAM9X5-EK		REV. 1/1		SCALE 1/1		POWER SUPPLY	
Derak	11-Oct-10	XX	XX	XX	XX	XX	XX
Derak	10-JUN-10	XX	XX	XX	XX	XX	XX
DES.	DATE	VER.	DATE	REV.	DATE	REV.	DATE
						SHEET 4/14	

The agreement is our property. Reproduction and publication without our written authorization will expose offenders to legal proceedings.



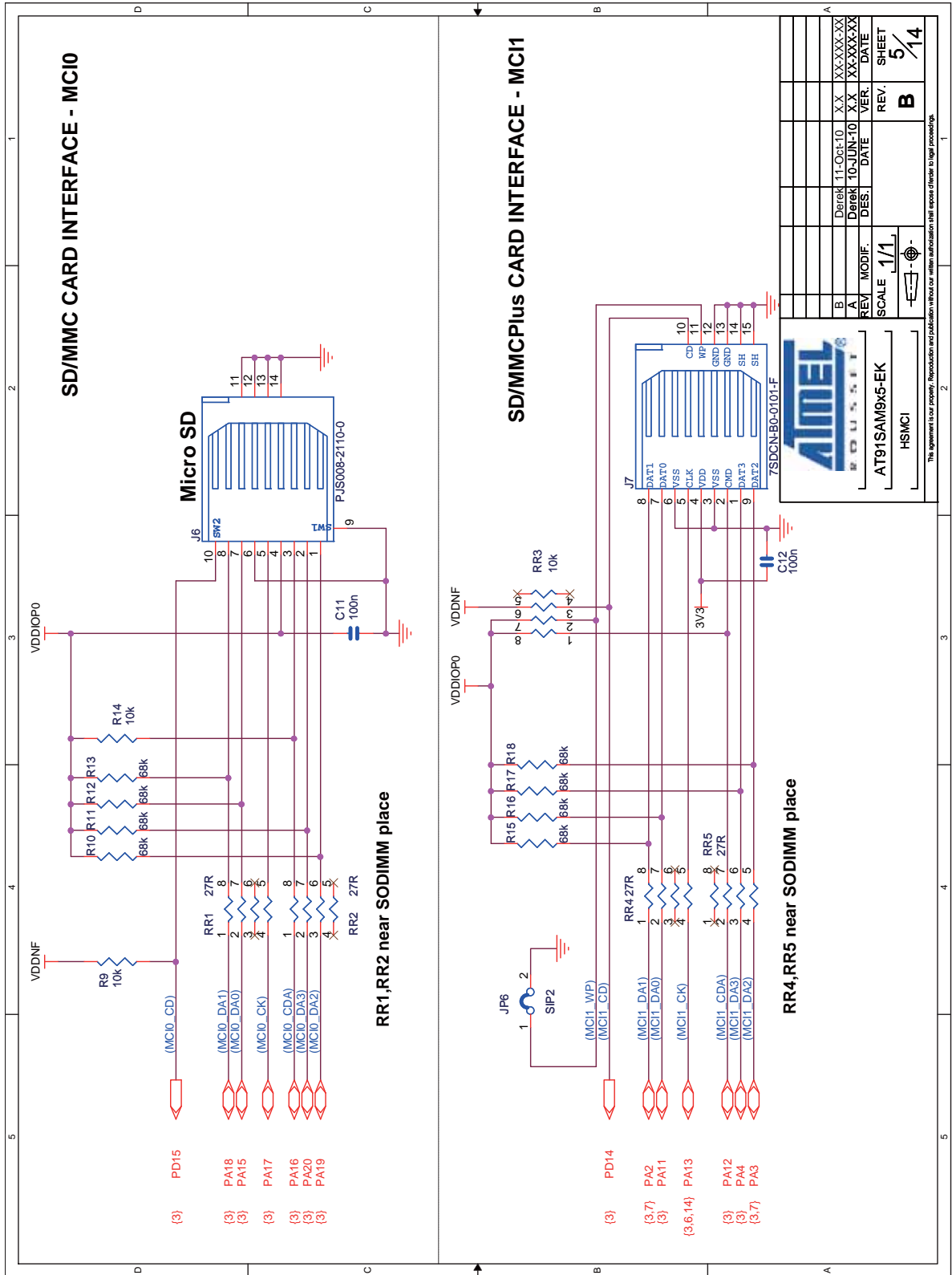















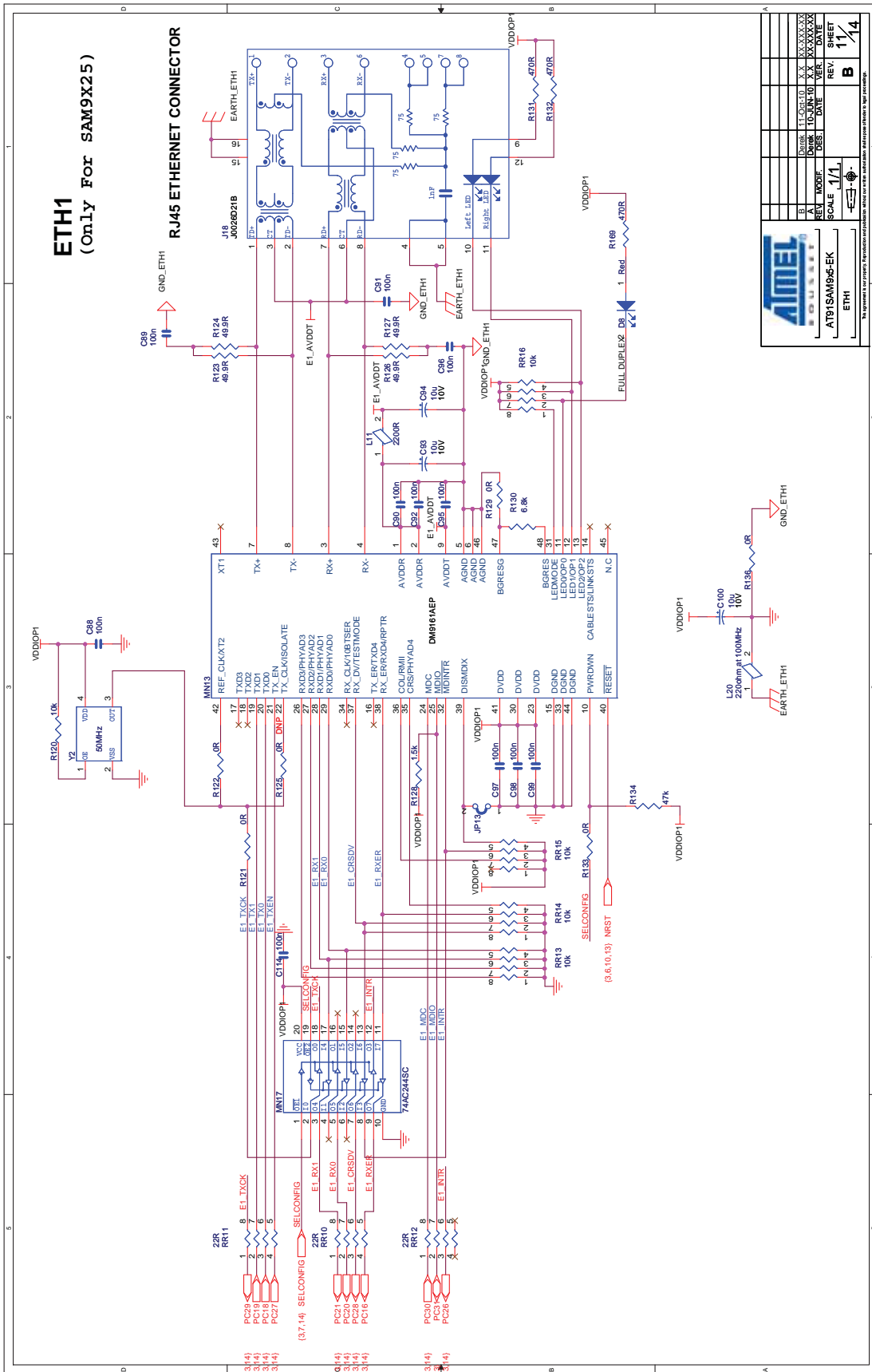

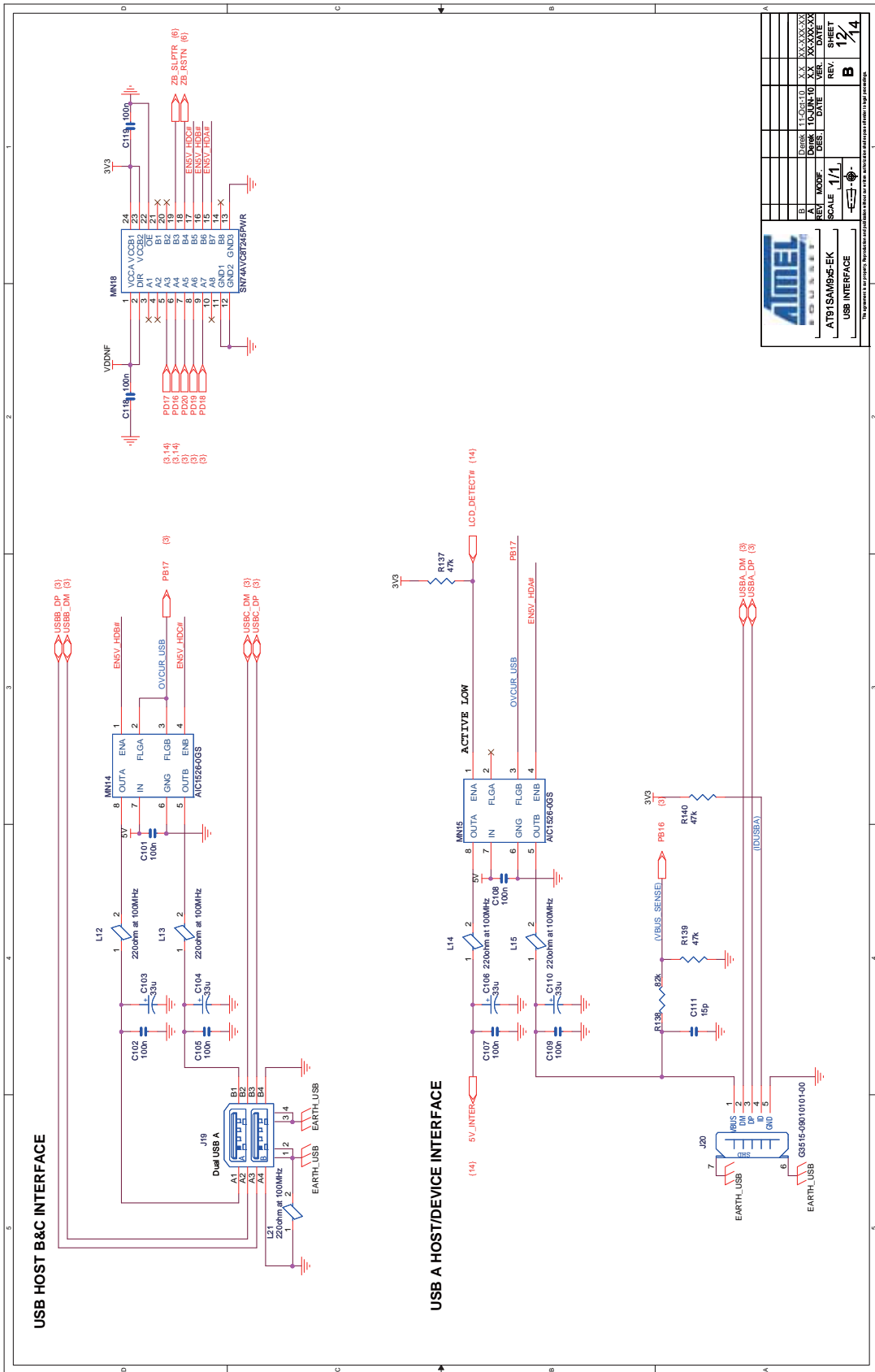

<b>ATMEL</b>		AT91SAM9G45-EK		SCALE	1/1	REV.	B	SHEET	12/14
DATE	11/04/10	DESIGNER	XXXXXX	DATE	11/04/10	REV.	1	DATE	11/04/10
REV.	1	MODIF.	XXXXXX	DATE	11/04/10	REV.	1	DATE	11/04/10
DESIGNER	XXXXXX	DESIGNER	XXXXXX	DATE	11/04/10	REV.	1	DATE	11/04/10
DATE	11/04/10	DESIGNER	XXXXXX	DATE	11/04/10	REV.	1	DATE	11/04/10

The information in this document is furnished in accordance with the information and data provided in the product data sheet.

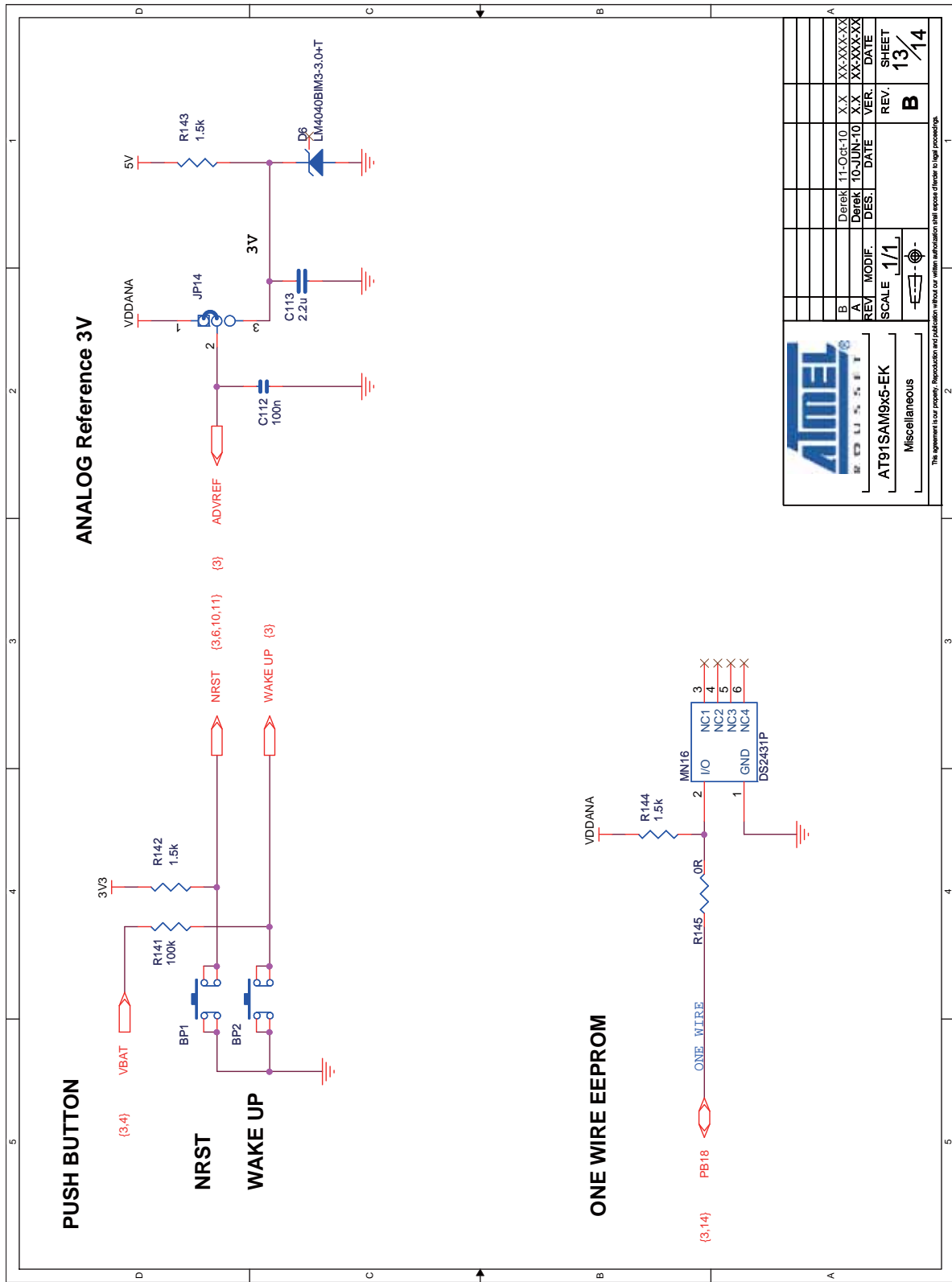

AT91SAM9X5-EK  
Miscellaneous

REV	MODIF.	DATE	DES.	DATE	DES.	DATE	DES.	DATE	DES.	DATE
1/1										
SCALE	1/1									
REV.	B									
SHEET	13/14									

The agreement is our property. Reproduction and publication without our written authorization shall expose offenders to legal proceedings.





## 3.4 Optional Display Module (DM) Board Hardware

### 3.4.1 DM Board Overview

The optional DM board carries a 5.0" TFT LCD module with touch screen. The DM board also carries four QTouch pads.

Figure 3-55. DM Board Layout



### 3.4.2 Equipment List

The list of the DM board components follows:

- One 5.0" TFT LCD module
- LCD Back light driver
- 3.3V regulator
- QTouch device
- 1-Wire device

### 3.4.3 Function Blocks

#### 3.4.3.1 3.3V Regulator

The DM Board features its own LDO for local power regulation. It accepts DC 5V power from a 500 mA high-side power switch on the EK and outputs a regulated +3.3 V to most other circuits on the board.

Figure 3-56. DM Board Power Supply

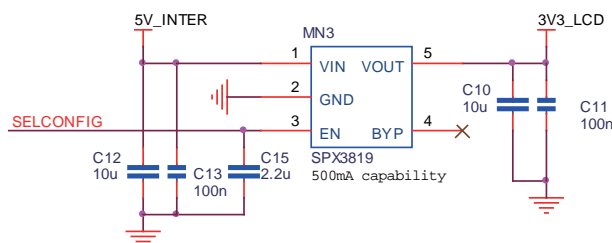

### 3.4.3.2 TFT LCD with Touch Panel

A 5" 800x480 LCD provides the DM with a low power display feature, back light unit and a touch panel, similar to that used on commercial PDAs.

Graphics and text can be displayed on the dot matrix panel with up to 16 million colors by supplying 24-bit data signals (8bit x RGB by default) or 16-bit data signals (5+6+5bit x RGB in option). This allows the user to develop graphical user interfaces for a wide variety of end applications.

**Warning:** Never connect/disconnect the LCD display from the board while the power supply is on. Doing so may damage both units.

Figure 3-57. LCD with Touch Panel

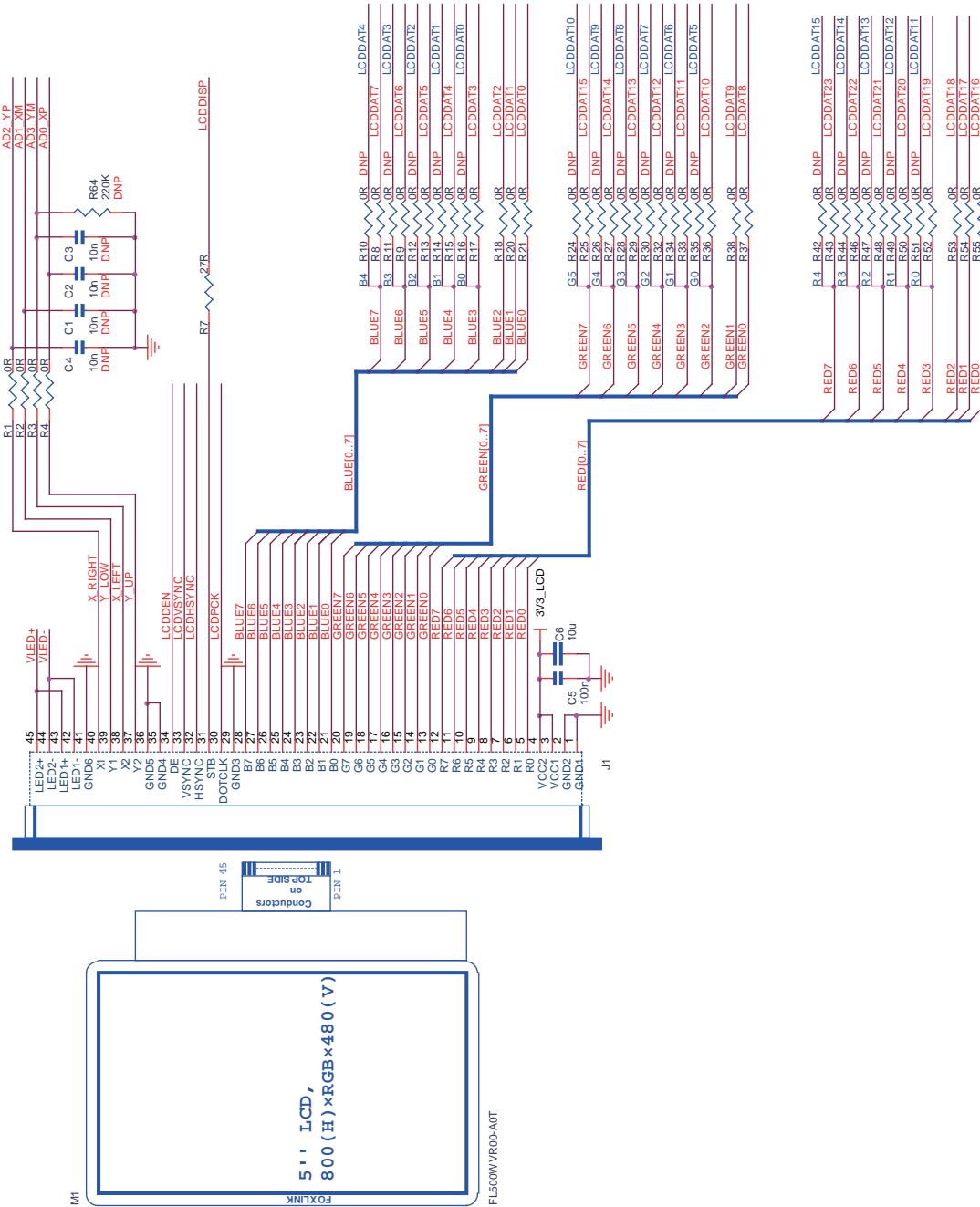

### 3.4.3.3 Back Light

The back light voltage is generated from a CP2122ST boost converter. It is powered directly by the DC 5V from the EK board. The back light level is controlled by a PWM signal generated from the MPU Device processor.

Figure 3-58. Back Light Control

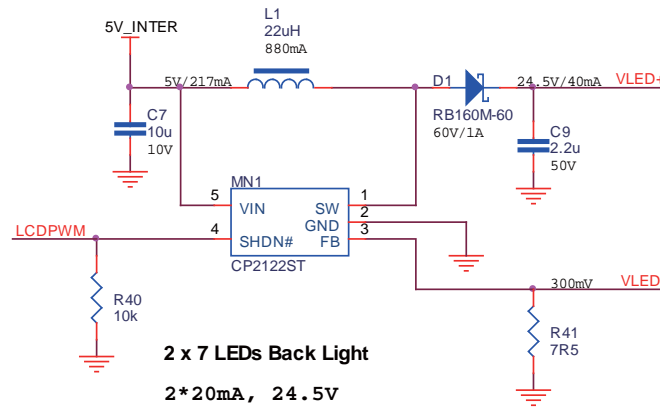

### 3.4.3.4 QTouch

The DM board carries a QTouch device piloted through a TWI interface. It manages four capacitive touch buttons directly printed on the PCB.

There are dual footprints for the QTouch device, and SOIC is the default mounted one.

Figure 3-59. QTouch

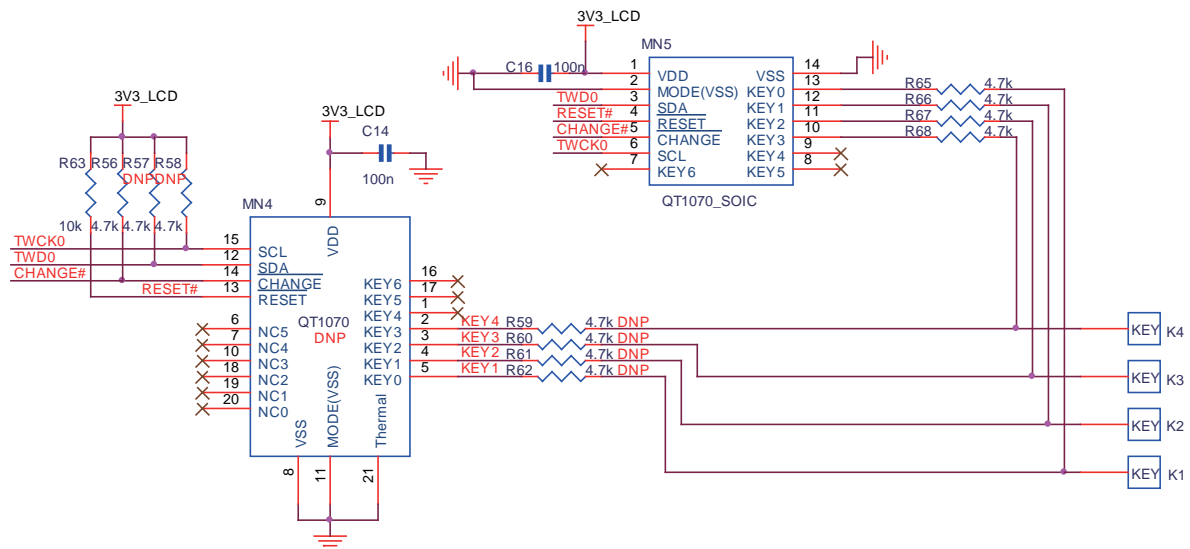

### 3.4.3.5 1-Wire

The DM board also uses a 1-Wire device as “firmware label” to store the information such as chip type, manufacturer’s name, production date etc.

**Figure 3-60. 1-Wire on DM**

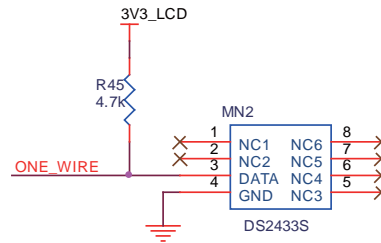

### 3.4.4 Schematics

Figure 3-61. DM Board Schematics

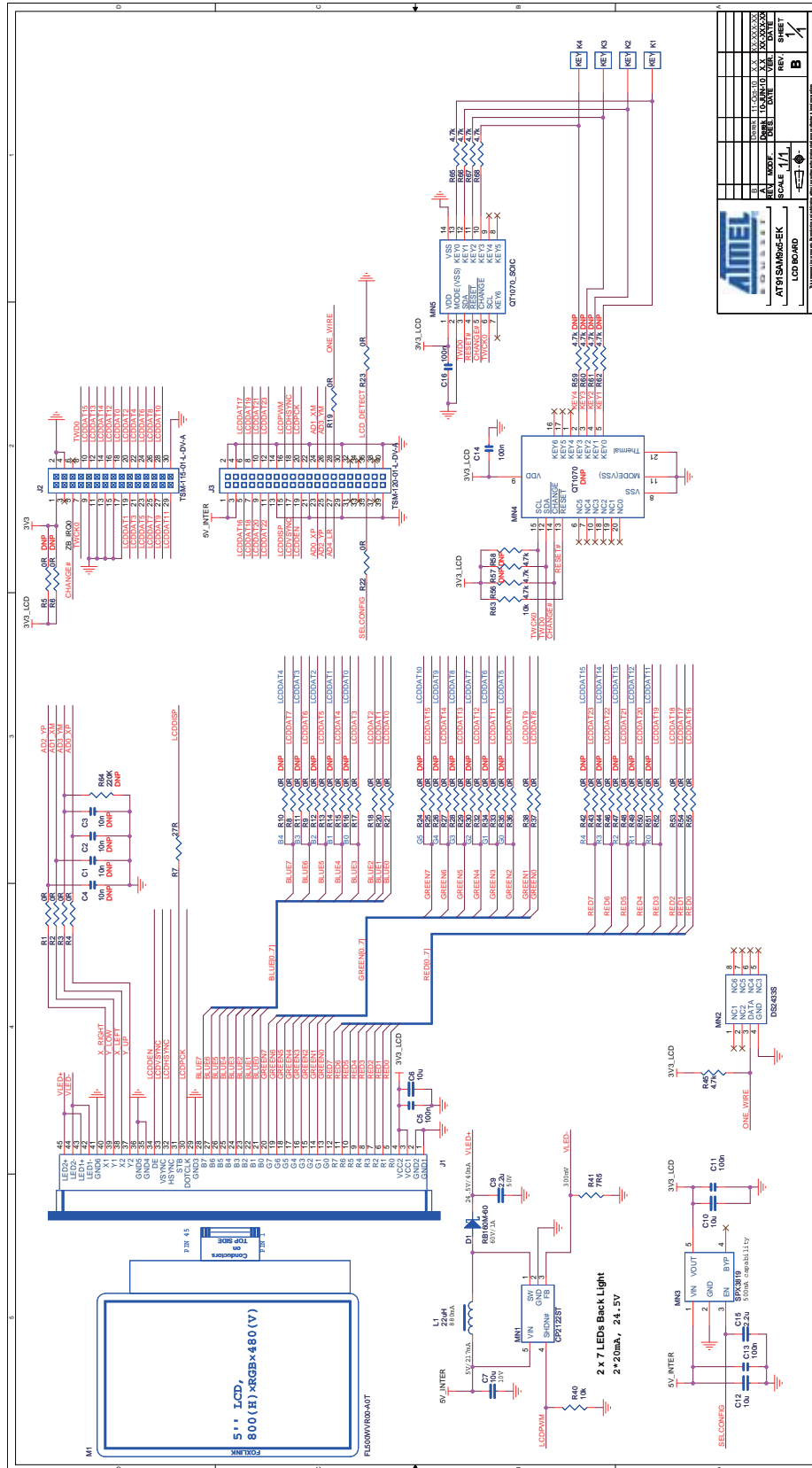

REV	DATE	BY	CHKD
1	11/11/05	ATMEL	ATMEL
2	11/11/05	ATMEL	ATMEL
3	11/11/05	ATMEL	ATMEL
4	11/11/05	ATMEL	ATMEL
5	11/11/05	ATMEL	ATMEL
6	11/11/05	ATMEL	ATMEL
7	11/11/05	ATMEL	ATMEL
8	11/11/05	ATMEL	ATMEL
9	11/11/05	ATMEL	ATMEL
10	11/11/05	ATMEL	ATMEL
11	11/11/05	ATMEL	ATMEL
12	11/11/05	ATMEL	ATMEL
13	11/11/05	ATMEL	ATMEL
14	11/11/05	ATMEL	ATMEL
15	11/11/05	ATMEL	ATMEL
16	11/11/05	ATMEL	ATMEL
17	11/11/05	ATMEL	ATMEL
18	11/11/05	ATMEL	ATMEL
19	11/11/05	ATMEL	ATMEL
20	11/11/05	ATMEL	ATMEL
21	11/11/05	ATMEL	ATMEL
22	11/11/05	ATMEL	ATMEL
23	11/11/05	ATMEL	ATMEL
24	11/11/05	ATMEL	ATMEL
25	11/11/05	ATMEL	ATMEL
26	11/11/05	ATMEL	ATMEL
27	11/11/05	ATMEL	ATMEL
28	11/11/05	ATMEL	ATMEL
29	11/11/05	ATMEL	ATMEL
30	11/11/05	ATMEL	ATMEL
31	11/11/05	ATMEL	ATMEL
32	11/11/05	ATMEL	ATMEL
33	11/11/05	ATMEL	ATMEL
34	11/11/05	ATMEL	ATMEL
35	11/11/05	ATMEL	ATMEL
36	11/11/05	ATMEL	ATMEL
37	11/11/05	ATMEL	ATMEL
38	11/11/05	ATMEL	ATMEL
39	11/11/05	ATMEL	ATMEL
40	11/11/05	ATMEL	ATMEL
41	11/11/05	ATMEL	ATMEL
42	11/11/05	ATMEL	ATMEL
43	11/11/05	ATMEL	ATMEL
44	11/11/05	ATMEL	ATMEL
45	11/11/05	ATMEL	ATMEL
46	11/11/05	ATMEL	ATMEL
47	11/11/05	ATMEL	ATMEL
48	11/11/05	ATMEL	ATMEL
49	11/11/05	ATMEL	ATMEL
50	11/11/05	ATMEL	ATMEL
51	11/11/05	ATMEL	ATMEL
52	11/11/05	ATMEL	ATMEL
53	11/11/05	ATMEL	ATMEL
54	11/11/05	ATMEL	ATMEL
55	11/11/05	ATMEL	ATMEL
56	11/11/05	ATMEL	ATMEL
57	11/11/05	ATMEL	ATMEL
58	11/11/05	ATMEL	ATMEL
59	11/11/05	ATMEL	ATMEL
60	11/11/05	ATMEL	ATMEL
61	11/11/05	ATMEL	ATMEL
62	11/11/05	ATMEL	ATMEL
63	11/11/05	ATMEL	ATMEL
64	11/11/05	ATMEL	ATMEL
65	11/11/05	ATMEL	ATMEL
66	11/11/05	ATMEL	ATMEL
67	11/11/05	ATMEL	ATMEL
68	11/11/05	ATMEL	ATMEL
69	11/11/05	ATMEL	ATMEL
70	11/11/05	ATMEL	ATMEL
71	11/11/05	ATMEL	ATMEL
72	11/11/05	ATMEL	ATMEL
73	11/11/05	ATMEL	ATMEL
74	11/11/05	ATMEL	ATMEL
75	11/11/05	ATMEL	ATMEL
76	11/11/05	ATMEL	ATMEL
77	11/11/05	ATMEL	ATMEL
78	11/11/05	ATMEL	ATMEL
79	11/11/05	ATMEL	ATMEL
80	11/11/05	ATMEL	ATMEL
81	11/11/05	ATMEL	ATMEL
82	11/11/05	ATMEL	ATMEL
83	11/11/05	ATMEL	ATMEL
84	11/11/05	ATMEL	ATMEL
85	11/11/05	ATMEL	ATMEL
86	11/11/05	ATMEL	ATMEL
87	11/11/05	ATMEL	ATMEL
88	11/11/05	ATMEL	ATMEL
89	11/11/05	ATMEL	ATMEL
90	11/11/05	ATMEL	ATMEL
91	11/11/05	ATMEL	ATMEL
92	11/11/05	ATMEL	ATMEL
93	11/11/05	ATMEL	ATMEL
94	11/11/05	ATMEL	ATMEL
95	11/11/05	ATMEL	ATMEL
96	11/11/05	ATMEL	ATMEL
97	11/11/05	ATMEL	ATMEL
98	11/11/05	ATMEL	ATMEL
99	11/11/05	ATMEL	ATMEL
100	11/11/05	ATMEL	ATMEL



## 4. Revision History

Table 4-1. Revision History

Document	Comments
11115B	Replaced all occurrences of “DataFlash” with “serial Flash”. Updated <a href="#">Section 2.1 “Power Up the Board”</a> and <a href="#">Section 2.3 “Recovery Procedure”</a> . Deleted section “DevStart”. Updated <a href="#">Table 3-7 “Boot Configuration”</a> . Added <a href="#">Figure 3-10, “SW1A and SW1B Position on Embest Modules”</a> . Updated <a href="#">Figure 3-14, “CM Board Schematics – 3 of 5”</a> .
11115A	First issue.



Atmel® | Enabling Unlimited Possibilities®



Atmel Corporation 1600 Technology Drive, San Jose, CA 95110 USA T: (+1)(408) 441.0311 F: (+1)(408) 436.4200 | [www.atmel.com](http://www.atmel.com)

© 2016 Atmel Corporation. / Rev.: Atmel-11115B-ATARM-SAM9G15-SAM9G25-SAM9G35-SAMX25-SAM9X35-User-Guide\_05-Feb-16.

Atmel®, Atmel logo and combinations thereof, Enabling Unlimited Possibilities®, and others are registered trademarks or trademarks of Atmel Corporation in U.S. and other countries. ARM®, ARM Connected® logo, and others are the registered trademarks or trademarks of ARM Ltd. Other terms and product names may be trademarks of others.

**DISCLAIMER:** The information in this document is provided in connection with Atmel products. No license, express or implied, by estoppel or otherwise, to any intellectual property right is granted by this document or in connection with the sale of Atmel products. EXCEPT AS SET FORTH IN THE ATMEL TERMS AND CONDITIONS OF SALES LOCATED ON THE ATMEL WEBSITE, ATMEL ASSUMES NO LIABILITY WHATSOEVER AND DISCLAIMS ANY EXPRESS, IMPLIED OR STATUTORY WARRANTY RELATING TO ITS PRODUCTS INCLUDING, BUT NOT LIMITED TO, THE IMPLIED WARRANTY OF MERCHANTABILITY, FITNESS FOR A PARTICULAR PURPOSE, OR NON-INFRINGEMENT. IN NO EVENT SHALL ATMEL BE LIABLE FOR ANY DIRECT, INDIRECT, CONSEQUENTIAL, PUNITIVE, SPECIAL OR INCIDENTAL DAMAGES (INCLUDING, WITHOUT LIMITATION, DAMAGES FOR LOSS AND PROFITS, BUSINESS INTERRUPTION, OR LOSS OF INFORMATION) ARISING OUT OF THE USE OR INABILITY TO USE THIS DOCUMENT, EVEN IF ATMEL HAS BEEN ADVISED OF THE POSSIBILITY OF SUCH DAMAGES. Atmel makes no representations or warranties with respect to the accuracy or completeness of the contents of this document and reserves the right to make changes to specifications and products descriptions at any time without notice. Atmel does not make any commitment to update the information contained herein. Unless specifically provided otherwise, Atmel products are not suitable for, and shall not be used in, automotive applications. Atmel products are not intended, authorized, or warranted for use as components in applications intended to support or sustain life.

**SAFETY-CRITICAL, MILITARY, AND AUTOMOTIVE APPLICATIONS DISCLAIMER:** Atmel products are not designed for and will not be used in connection with any applications where the failure of such products would reasonably be expected to result in significant personal injury or death ("Safety-Critical Applications") without an Atmel officer's specific written consent. Safety-Critical Applications include, without limitation, life support devices and systems, equipment or systems for the operation of nuclear facilities and weapons systems. Atmel products are not designed nor intended for use in military or aerospace applications or environments unless specifically designated by Atmel as military-grade. Atmel products are not designed nor intended for use in automotive applications unless specifically designated by Atmel as automotive-grade.