

OHSM100-60803CF Surface Mount OCXO

CONNOR WINFIELD



2111 Comprehensive Drive
Aurora, Illinois 60505
Phone: 630-851-4722
Fax: 630-851-5040
www.conwin.com

US Headquarters:
630-851-4722
European Headquarters:
+353-61-472221

Description:

Connor-Winfield's model OHSM100-60803CF is a 3.3 Vdc, Oven Compensated Crystal Oscillator (OCXO) in a 25.4 x 25.4 mm surface mount package. The OHSM100-60803CF is designed for timing and synchronization applications per the following standards: IEEE 1588; ITU-T G.812 Type III; Telcordia Stratum 3E

Features:

- Output Frequency: 10 MHz or 20 MHz
- 3.3 Vdc Operation
- 25.4 x 25.4 mm SMT Package
- Frequency Stability: ± 8.0 ppb -40 to 85C
- LVCMOS Output
- Low Jitter / Low Phase Noise
- STRATUM 3E Compliant
- RoHS Compliant / Lead Free

Absolute Maximum Ratings

Parameter	Minimum	Nominal	Maximum	Units	Notes
Storage Temperature	-55	-	125	°C	
Supply Voltage (Vcc)	-0.5	-	4.5	Vdc	

Operating Specifications

Parameter	Minimum	Nominal	Maximum	Units	Notes
Operating Temperature	-40	-	85	°C	
Supply Voltage (Vcc)	3.135	3.3	3.465	Vdc	$\pm 5\%$
Power Consumption					
During Warm Up:	-	3.5	4.0	W	
Steady State @ 25°C:	-	1.5	-	W	
Start-Up Time	-	-	50	ms	1
Load (Output to Ground)	5	10	15	pF	

Frequency Stability

Parameter	Minimum	Nominal	Maximum	Units	Notes
Frequency (Fo)	-	10.0 or 20.0	-	MHz	
Frequency Calibration @ 25°C:	-0.5	-	0.5	ppm	2
Frequency vs. Temperature	-8.0	-	8.0	ppb	3
Frequency vs. Supply Voltage	-	± 1.0	-	ppb	Vcc $\pm 5\%$
Aging					
Per day, at time of shipment	-	± 0.5	± 1.0	ppb/day	
20 Years	-	-	± 1.5	ppm	
24 Hour Holdover Stability					
Constant temperature	-	± 0.5	± 1.0	ppb	4
Inclusive of all conditions	-	± 8.0	± 10.0	ppb	
Total Free-Run Accuracy	-	-	± 2.1	ppm	
Short Term Stability ADEV (in still air)					
1.0 sec	-	<0.01	0.02	ppb	
10 sec	-	0.01	0.03	ppb	
100 sec	-	0.02	0.05	ppb	
1000 sec	-	0.05	0.1	ppb	
10,000 sec	-	0.07	0.2	ppb	
Wander Generation	MTIE and TDEV per STRATUM 3E requirements of Telcordia GR-1244-CORE and GR-253-CORE				
Warm-up Time	-	-	15	minutes	5

Phase Noise

Parameter	Minimum	Nominal	Maximum	Units	Notes
SSB Phase Noise at 1Hz offset	-	-80	-70	dBc/Hz	
SSB Phase Noise at 10Hz offset	-	-110	-105	dBc/Hz	
SSB Phase Noise at 100Hz offset	-	-130	-125	dBc/Hz	
SSB Phase Noise at 1KHz offset	-	-140	-125	dBc/Hz	
SSB Phase Noise at 10KHz offset	-	-150	-145	dBc/Hz	

Sub-Harmonics

Parameter	Minimum	Nominal	Maximum	Units	Notes
Sub-Harmonics	-	-	-25	dBc	



Bulletin **Cx265**
Page **1 of 2**
Revision **04**
Date **06 March 2015**



LVMOS Output Characteristics

Parameter	Minimum	Nominal	Maximum	Units
Voltage: (Low) Vol	-	-	10%Vcc	V
Voltage: (High) Voh	90%Vcc	-	-	V
Rise / Fall Times @ 20% to 80%	-	4	10	ns
Duty Cycle: @ 1.65V	40	50	60	%

Package Characteristics

Package Hermetically sealed welded package mounted on a FR4 substrate.

Notes:

- To 90% Output Amplitude.
- Initial calibration frequency measured @ 25°C, at time of shipment.
- Frequency stability vs. change in temperature $[\pm(F_{max}-F_{min})/2.F_0]$.
- Inclusive of variable operating temperatures and 24 hours aging drift. After 8 hours operation required if off for 4 hours, 24 hours operation required if off for up to 1 week, 48 hours operation required if off for up to 1 month.
- Temperature = 25°C, to within 10ppb of frequency @ 60 minutes

Environmental Characteristics

Shock	100 G's 3ms, Half sine, 3 shocks per direction, per MIL-STD 202F, Method 213B Test Condition D.
Sinusoidal Vibration	0.06" D.A. or 10G's Peak, 10 to 500 Hz, per MIL-STD 202F, Method 204D, Test Condition A.
Random Vibration	5.35 G's rms. 20 to 2000 Hz per MIL-STD-202F, Method 214, Test Condition 1A, 15 minutes each axis.
Altitude	70,000 ft max
Moisture	10 cycles, 95% RH, Per MIL-STD-202F, Method 112.
Marking Permanency	Per MIL-STD-202F, Method 215J.
Attachment Method PCB	Through Hole Mounted
Resistance to Solder Heat	Per MIL-STD-202F, Method 210, Condition E.
Solder Process	RoHS compliant, lead free. See solder profile.

Test Circuit

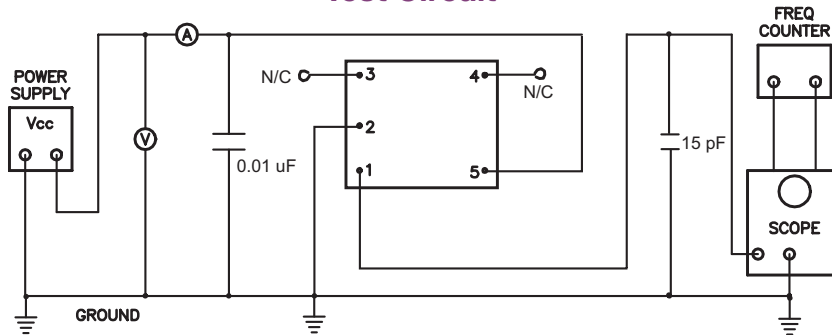

Solder Profile

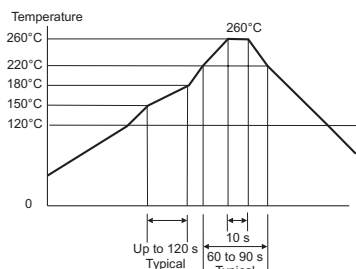

Meets IPC/JEDEC J-STD-020C

Pad Connections

Pad Connection	
1:	Output
2:	Ground (Case)
3:	N/C
4:	N/C
5:	Supply Voltage (Vcc)

Package Outline

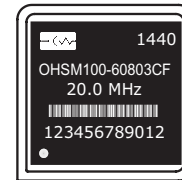

Date Code (YYWW)
Model Number
Output
Ser
Ser

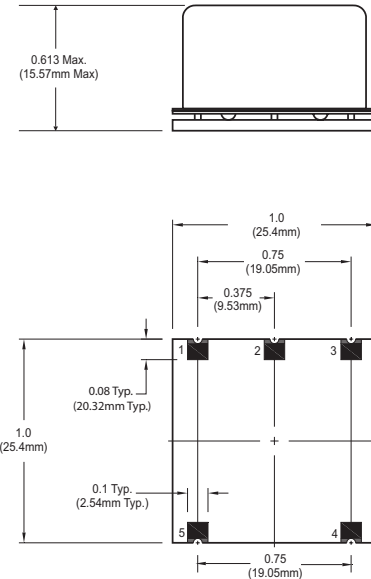

Suggested Pad Layout

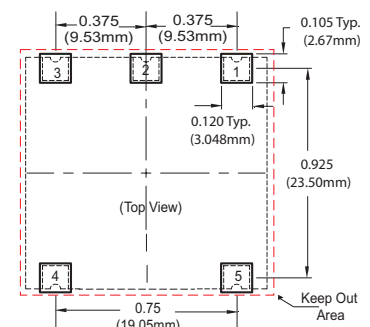

Ordering Information

OHSM100-60803CF - 020.0M

OCXO SERIES CENTER FREQUENCY

Bulletin **Cx265**
Page **2 of 2**
Revision **04**
Date **06 March 2015**