

250 V and 600 V cable limiters



Product description:

Cable limiters are intended to provide short-circuit protection to electrical systems, typically between the transformer and service entrance. Should a short-circuit occur, the cable limiter removes the affected cable(s) from service and permits the other conductors to continue delivering power.

Cable limiters are often used in utility low voltage networks and large multi-cable per phase service entrances.

Unlike fuses, cable limiters are selected by cable size rather than amperage, e.g., a "4/0" limiter will carry the current of a 4/0 cable.

Limiters are stable, totally self-contained, static devices with unchanging characteristics that operate without venting of ionized gases or explosive action.

Under high short-circuit conditions, limiters cut off fault currents within one-half cycle (0.008 seconds) and reduce insulation damage from the immense heat that is developed by sustained fault current flow. They confine damage to the point of the short-circuit and stop long-length cable burn-back and striking of multiple arcs to minimize damage to or eliminate damage to adjacent conductors.

Features and benefits:

- Cable limiters enhance multi-conductor system reliability by isolating faulted conductors and taking them offline while the balance of the conductors continue delivering power to their circuits. This is why cable limiters are often used in utility low voltage networks and large multi-cable per phase service entrances.
- Cable limiters enhance service entrance conductor short-circuit protection with current-limiting performance that exceed the typical protection offered by utility overcurrent protective devices.
- Cable limiters meet many system requirements with 250Vac or 600Vac ratings for conductor sizes from 12AWG to 1000kcmil and terminal options available that make them easy to install including: tube-to-tube (crimp), tube-to-bolt (crimp/bolt-in), compression rod-to-tube (crimp) and bolt-to-offset bolt (bolt-in) options.
- Select cable limiters are UL® Listed under File E90818 for use on 600V circuit for the protection of faults up to 200kA.

250V UH Series

Catalog Symbol: UH__

Applications:

- The 250 Vac UH cable limiters are designed specifically for use in residential applications.

Ratings:

- Volts: up to 250 Vac
- Interrupting Rating: 100 kA, RMS Sym.

Terminals:

- Center bolt-to-offset bolt — copper or aluminum conductors

Conductors:

- Copper or aluminum conductors are permitted per the listed cable size. Select the catalog symbol for the system conductor size in the table below.

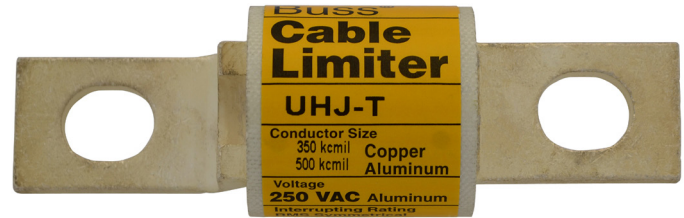

Dimensions - in (mm)

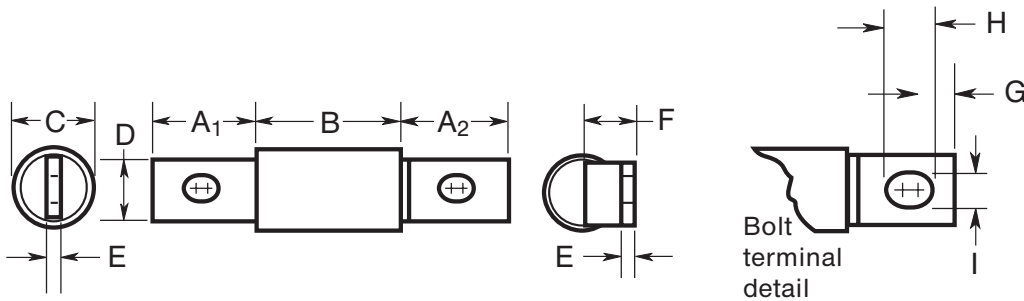

Catalog numbers	Copper cable size	Aluminum cable size	A ₁	A ₂	B	C	D	E	F	G	H	I
UHA	2/0-3/0 AWG	4/0 AWG	1.06 (27.0)	1.19 (30.2)	1.44 (36.5)	1.00 (25.4)	0.75 (19.0)	0.12 (3.2)	0.56 (14.3)	0.19 (4.8)	0.59 (15.1)	0.41 (10.3)
UHJ-M	3/0 AWG	250 kcmil	1.53 (38.9)	1.75 (44.4)	1.59 (40.5)	1.50 (38.1)	1.00 (25.4)	0.25 (6.3)	0.87 (22.2)	0.34 (8.6)	0.69 (17.5)	0.56 (14.3)
UHJ-T	350 kcmil	500 kcmil	1.53 (38.9)	1.75 (44.4)	1.59 (40.5)	1.50 (38.1)	1.00 (25.4)	0.25 (6.3)	0.87 (22.2)	0.34 (8.6)	0.69 (17.5)	0.56 (14.3)
UHJ-W	600 kcmil	800 kcmil	1.53 (38.9)	1.75 (44.4)	1.59 (40.5)	1.50 (38.1)	1.00 (25.4)	0.25 (6.3)	0.87 (22.2)	0.34 (8.6)	0.69 (17.5)	0.56 (14.3)

600V K Series

Catalog Symbol: K__

Applications:

The 600 Vac K cable limiters are designed for use on non-residential 277/480, 120/208 and 120/240 volt systems.

Ratings:

- Volts: up to 600 Vac
- Interrupting Rating: 200 kA, RMS Sym.

Agency information:

- KCD, KCJ, KCM, KCR, KDM, KDR, KDP and KFM cable limiters are UL Listed under File E90818 for only copper conductors.

Terminals:

- Tube-to-tube
- Tube-to-offset bolt
- Compression rod-to-tube
- Center bolt-to-offset bolt

Conductors:

- Copper only on:
 - Tube-to-tube
 - Tube-to-offset bolt
 - Compression rod-to-tube
- Copper or aluminum on
 - Center bolt-to-offset bolt

Terminals:

- Tube-to-tube — copper conductor only

Dimensions - in (mm)

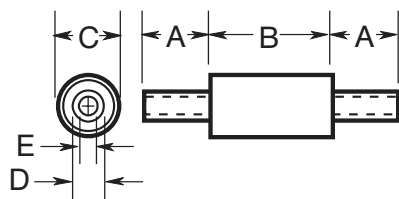

Catalog symbol	Copper cable size	A	B	C	D	E
KCY	4AWG	1.25 (31.8)	2.88 (73.0)	1.06 (27.0)	0.31 (7.9)	0.25 (6.4)
KCZ	3AWG	1.25 (31.8)	2.88 (73.0)	1.06 (27.0)	0.34 (8.7)	0.28 (7.1)
KCA	2AWG	1.25 (31.8)	2.88 (73.0)	1.06 (27.0)	0.44 (11.1)	0.31 (7.9)
KCB	1AWG	1.25 (31.8)	2.88 (73.0)	1.06 (27.0)	0.47 (11.9)	0.34 (8.7)
KCC	1/0AWG	1.5 (38.1)	2.625 (66.7)	1.25 (31.8)	0.52 (13.1)	0.39 (9.9)
KCD*, †	2/0AWG	1.63 (41.3)	2.625 (66.7)	1.25 (31.8)	0.44 (14.3)	0.70 (11.1)
KCE	3/0AWG	1.63 (41.3)	3.63 (92.1)	1.44 (36.5)	0.61 (15.5)	0.48 (12.3)
KCF	4/0AWG	1.75 (44.5)	3.63 (92.1)	1.44 (36.5)	0.34 (17.5)	0.55 (14.0)
KCH	250kcmil	1.88 (47.6)	3.63 (92.1)	1.44 (36.5)	0.75 (19.0)	0.59 (15.0)
KCJ**	350kcmil	2.0 (50.8)	3.63 (92.1)	1.63 (41.3)	0.88 (22.2)	0.70 (17.9)
KCM*, †, ††	500kcmil	2.88 (73.0)	3.08 (78.2)	1.88 (47.6)	1.06 (27.0)	0.83 (21.0)
KCV	600kcmil	3.5 (88.9)	3.08 (78.2)	1.88 (47.6)	1.155 (29.3)	0.92 (23.4)
KCR*, †	750kcmil	3.5 (88.9)	3.75 (95.25)	2.5 (63.5)	1.31 (33.3)	1.06 (27.0)
KCS	1000kcmil	5.0 (127.0)	3.75 (95.25)	2.5 (63.5)	1.56 (39.7)	1.22 (31.0)

* UL Listed, File E90818, 600Vac, 200kA I.R.

† Available with shrink tube “-V” suffix.

†† Available with molded rubber boot “-B” suffix. Boot can be purchased separately, order Part# - BOOT-KCM

Effective October 2016

Terminals:

- Tube-to-offset bolt — copper conductor only

Dimensions - in (mm)

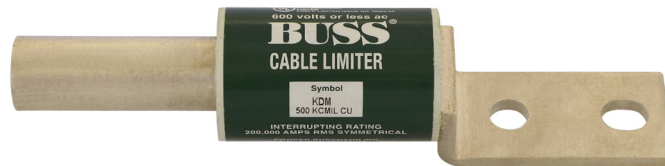
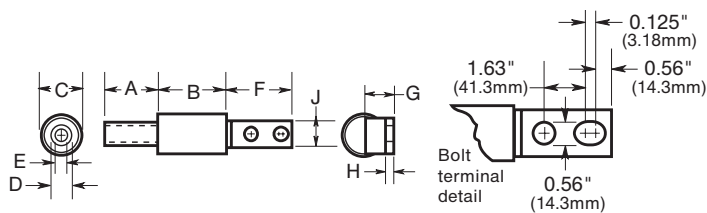

Catalog symbol	Copper cable size	A	B	C	D	E	F	G	H	J
KQV	12AWG	1.25 (31.8)	2.88 (73.0)	1.06 (27.0)	0.19 (4.8)	0.125 (3.2)	3.31 (84.1)	0.72 (18.3)	0.19 (4.8)	1.125 (28.6)
KQT	10AWG	1.25 (31.8)	2.88 (73.0)	1.06 (27.0)	0.23 (6.0)	0.14 (3.6)	3.31 (84.1)	0.72 (18.3)	0.19 (4.8)	1.125 (28.6)
KFZ	8AWG	1.25 (31.8)	2.88 (73.0)	1.06 (27.0)	0.23 (6.0)	0.16 (4.0)	3.31 (84.1)	0.72 (18.3)	0.19 (4.8)	1.125 (28.6)
KIG	6AWG	1.25 (31.8)	2.88 (73.0)	1.06 (27.0)	0.31 (7.9)	0.16 (4.0)	3.31 (84.1)	0.72 (18.3)	0.19 (4.8)	1.125 (28.6)
KDY	4AWG	1.25 (31.8)	2.88 (73.0)	1.06 (27.0)	0.31 (7.9)	0.25 (6.4)	3.31 (84.1)	0.72 (18.3)	0.19 (4.8)	1.125 (28.6)
KDA	2AWG	1.25 (31.8)	2.88 (73.0)	1.06 (27.0)	0.44 (11.1)	0.31 (7.9)	3.31 (84.1)	0.72 (18.3)	0.19 (4.8)	1.125 (28.6)
KDB	1AWG	1.25 (31.8)	2.88 (73.0)	1.06 (27.0)	0.47 (11.9)	0.34 (8.7)	3.31 (84.1)	0.72 (18.3)	0.19 (4.8)	1.125 (28.6)
KDC	1/0AWG	1.5 (38.1)	2.625 (66.7)	1.25 (31.8)	0.52 (13.1)	0.39 (9.9)	3.38 (85.7)	0.88 (22.2)	0.25 (6.4)	1.125 (28.6)
KDD	2/0AWG	1.63 (41.3)	2.625 (66.7)	1.25 (31.8)	0.56 (14.3)	0.44 (11.1)	3.38 (85.7)	0.88 (22.2)	0.25 (6.4)	1.125 (28.6)
KDE	3/0AWG	1.63 (41.3)	3.63 (92.1)	1.44 (36.5)	0.61 (15.5)	0.48 (12.3)	3.38 (85.7)	0.97 (24.6)	0.25 (6.4)	1.125 (28.6)
KDF	4/0AWG	1.75 (44.5)	3.63 (92.1)	1.44 (36.5)	0.69 (17.5)	0.55 (13.9)	3.38 (85.7)	0.97 (24.6)	0.25 (6.4)	1.125 (28.6)
KDH	250kcmil	1.88 (47.6)	3.63 (92.1)	1.44 (36.5)	0.75 (19.0)	0.59 (15.0)	3.38 (85.7)	0.97 (24.6)	0.25 (6.4)	1.125 (28.6)
KDJ†	350kcmil	2.0 (50.8)	3.63 (92.1)	1.63 (41.3)	0.88 (22.2)	0.70 (17.8)	3.38 (85.7)	1.06 (27.0)	0.25 (6.4)	1.125 (28.6)
KDM*,†	500kcmil	2.88 (73.0)	3.08 (78.2)	1.88 (47.6)	1.06 (27.0)	0.83 (21.0)	3.38 (85.7)	1.19 (30.2)	0.25 (6.4)	1.63 (41.3)
KDU	600kcmil	3.5 (88.9)	3.75 (95.2)	2.5 (63.5)	1.16 (29.4)	0.92 (23.4)	3.5 (88.9)	1.5 (38.1)	0.25 (6.4)	2.0 (50.8)
KDR*, ††	750kcmil	3.5 (88.9)	3.75 (95.2)	2.5 (63.5)	1.31 (33.3)	1.06 (27.0)	3.5 (88.9)	1.5 (38.1)	0.25 (6.4)	2.0 (50.8)

* UL Listed, File E90818, 600Vac, 200kA I.R.

† Available with molded rubber boot “-B” suffix. Boot can be purchased separately, order Part# - BOOT-KDM

†† Available with shrink tube “-V” suffix.

Terminals:

- Compression rod-to-tube — copper conductor only

Dimensions - in (mm)

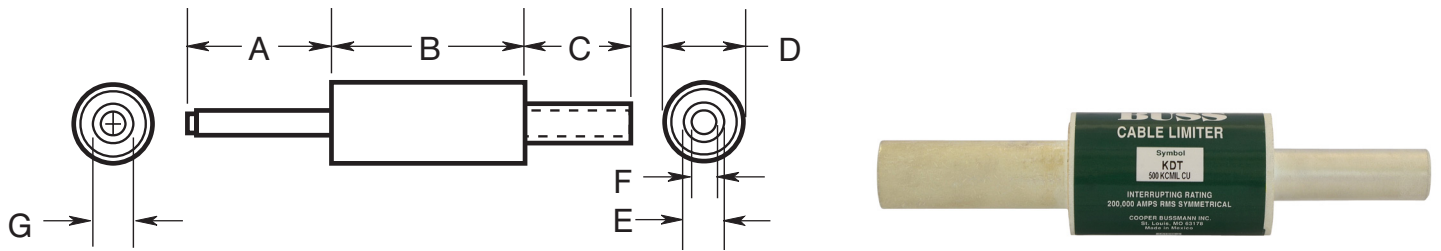

Catalog symbol	Copper cable size	A	B	C	D	E	F	G
KEX	4/0AWG	2.5 (63.5)	3.63 (92.1)	1.75 (44.5)	1.44 (36.5)	0.69 (17.5)	0.55 (13.9)	0.5 (12.7)
KFH-A	250kcmil	2.5 (63.5)	3.63 (92.1)	1.88 (47.6)	1.44 (36.5)	0.75 (19.0)	0.28 (15.1)	0.56 (14.3)
KQO	350kcmil	2.5 (63.5)	3.63 (92.1)	2.0 (50.8)	1.63 (41.3)	0.88 (22.2)	0.70 (17.8)	0.81 (20.6)
KDT	500kcmil	2.5 (63.5)	3.08 (78.2)	2.88 (73.0)	1.88 (47.6)	1.06 (27.0)	0.83 (21.0)	0.81 (20.6)

Terminals:

- Center bolt-to-offset bolt — copper or aluminum conductors

Dimensions - in (mm)

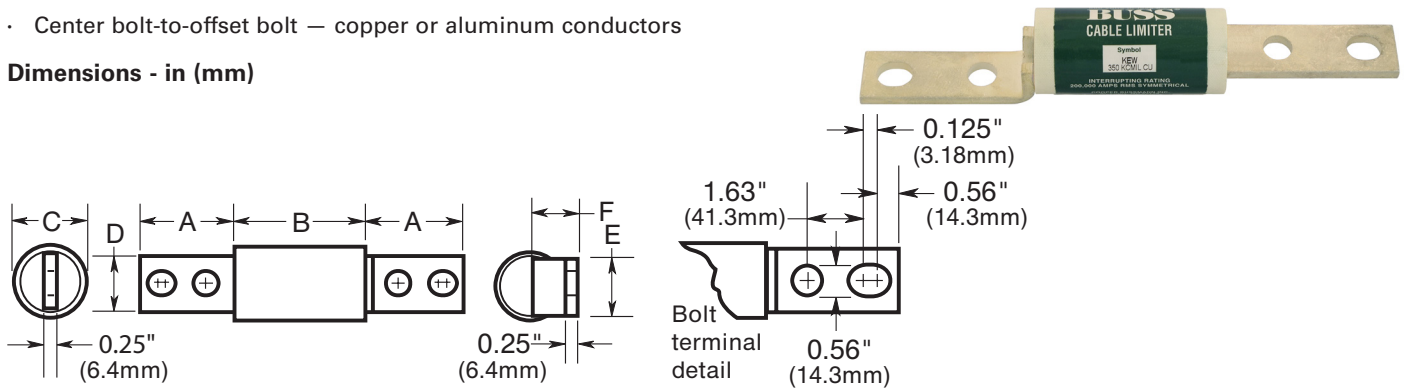

Catalog symbol	Copper cable size	Aluminum cable size	A	B	C	D	E	F
KPF	4/0AWG	4/0AWG	3.38 (85.7)	3.63 (92.1)	1.44 (36.5)	1.125 (28.6)	1.125 (28.6)	0.97 (24.6)
KFT	250kcmil	250kcmil	3.38 (85.7)	3.63 (92.1)	1.44 (36.5)	1.125 (28.6)	1.125 (28.6)	0.97 (24.6)
KEW	350kcmil	350kcmil	3.38 (85.7)	3.63 (92.1)	1.63 (41.3)	1.125 (28.6)	1.125 (28.6)	1.06 (27.0)
KDP*	500kcmil	500kcmil	3.38 (85.7)	3.08 (78.2)	1.88 (47.6)	1.5 (38.1)	1.63 (41.3)	1.19 (30.2)
KFM*	750kcmil	750kcmil	3.50 (88.9)	3.75 (95.3)	2.50 (63.5)	2.0 (50.8)	2.00 (50.8)	1.50 (38.1)

* UL Listed for copper only, File E90818, 600Vac, 200kA A.I.R.

Peak let-through current

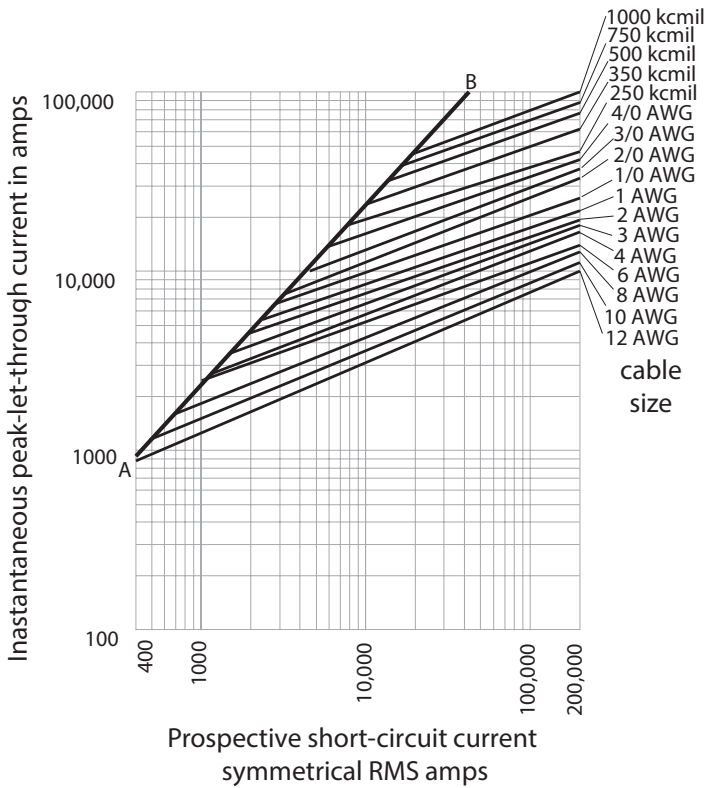

Time-current characteristics - total clear

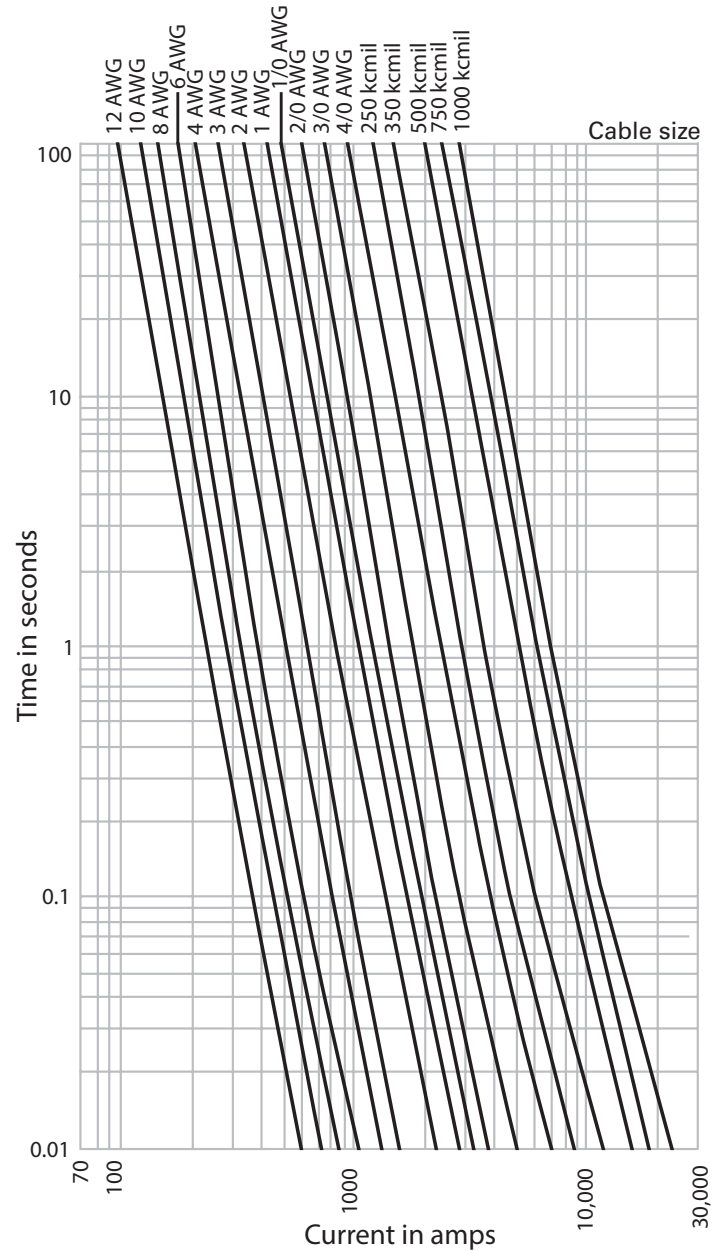

The only controlled copy of this data sheet is the electronic read-only version located on the Eaton network drive. All other copies of this document are by definition uncontrolled. This bulletin is intended to clearly present comprehensive product data and provide technical information that will help the end user with design applications. Eaton reserves the right, without notice, to change design or construction of any products and to discontinue or limit distribution of any products. Eaton also reserves the right to change or update, without notice, any technical information contained in this bulletin. Once a product has been selected, it should be tested by the user in all possible applications.

Eaton
 1000 Eaton Boulevard
 Cleveland, OH 44122
 United States
 Eaton.com

Bussmann Division
 114 Old State Road
 Ellisville, MO 63021
 United States
 Eaton.com/bussmannseries

© 2015 Eaton
 All Rights Reserved
 Printed in USA
 Publication No. 1042 – BU-SB14632
 October 2016

For Eaton's Bussmann series product information, call 1-855-287-7626 or visit: Eaton.com/bussmannseries

Eaton and Bussmann are valuable trademarks of Eaton in the US and other countries. You are not permitted to use the Eaton trademarks without prior written consent of Eaton.

UL is a registered trademark of the Underwriters Laboratories, Inc.

Follow us on social media to get the latest product and support information.

