

- ▶ Low Profile
- ▶ Wide Frequency range
- ▶ Extended temperature range
- ▶ Built-in load capacitance
- ▶ RoHS Compliant (Note 7 Exemption)

ZTT Series Ceramic Resonator

The ZTT Series ceramic resonator offers a wide frequency range and extended temperature range capabilities with built-in load capacitance.

OPERATING CONDITIONS / ELECTRICAL CHARACTERISTICS

PART NUMBER *	FREQUENCY RANGE (MHz)	FREQUENCY ACCURACY @ 25°C (%)	STABILITY IN TEMPERATURE -20~ +80°C (%)	AGING FOR TEN YEARS (%)	RESONANT RESISTANCE (Ω) MAX
ZTT□.□□MG	2.00 ~ 2.99	±0.5	±0.3	±0.3	80
ZTT□.□□MG	3.00 ~ 3.49	±0.5	±0.3	±0.3	50
ZTT□.□□MG	3.50 ~ 8.00	±0.5	±0.3	±0.3	30
ZTT□.□□MT	6.01 ~ 6.99	±0.5	±0.3	±0.3	30
ZTT□□.□□MT	7.00 ~ 13.00	±0.5	±0.3	±0.3	25
ZTT□□.□□MX	13.01 ~ 50.00	±0.5	±0.3	±0.3	30

- Withstanding voltage (5 seconds max.): 100V DC
- Insulation Resistance 100M Ω Min. (at 10 V DC)

PACKAGE DIMENSIONS (mm)

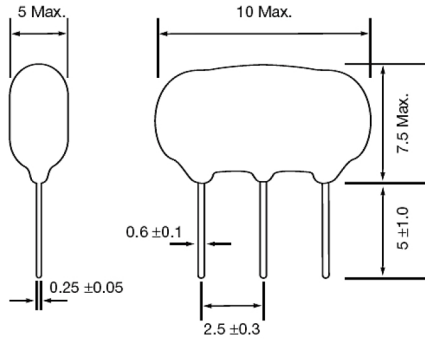

Figure 1) ZTT□.□□MG, Side and Front views

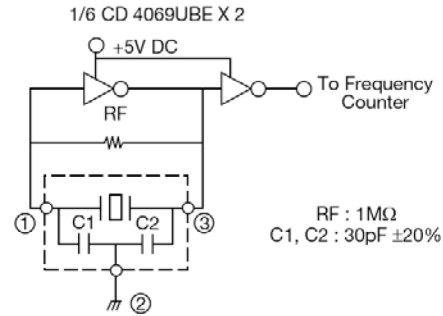

Figure 2) ZTT□.□□MG Test Circuit

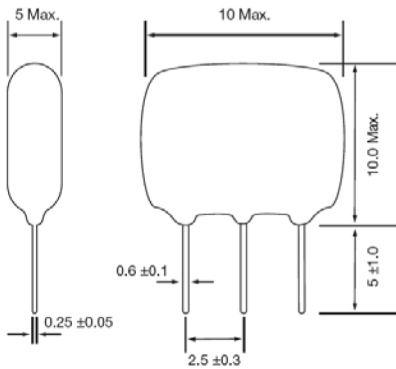

Figure 3) ZTT□.□□MT, MX Side and Front views

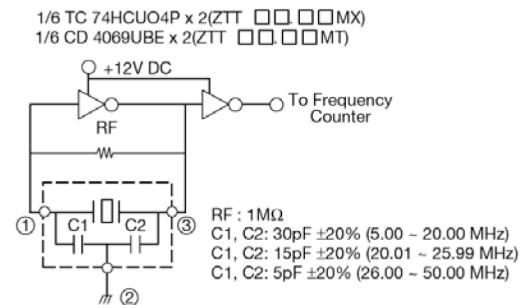
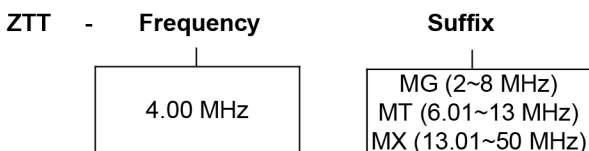

Figure 4) ZTT□.□□MT & ZTT□.□□MX Test Circuit

PART NUMBERING GUIDE: Example ZTT-4.00MG



Note: ECS does not approve the use of its products in Automotive, Military, Avionics, Life Sustaining or Life Support systems or any other related medical applications without written approval from ECS INC.