

FEATURES

- 0.2% Output Tolerance
- 0.6Ω Shunt Impedance
- 700μA to 10mA Operating Current
- Pin Compatible with LM136-5
- 20ppm/°C Max Drift
- Output Voltage Trim does not Affect Drift
- Can be Used as Positive or Negative Reference

APPLICATIONS

- A-to-D and D-to-A Converters
- Precision Regulators
- Precision Current Sources
- V to F and F to V Converters

DESCRIPTION

The LT[®]1029 is a 5V bandgap reference intended for use in the shunt or “Zener” mode, allowing it to be used as either a positive or negative reference. The output is pretrimmed to ±0.2% accuracy with 20ppm/°C maximum temperature drift. A trim pin allows additional output adjustment for even more precise output voltage.

Operating current range for the LT1029 is 700μA to 10mA. Extremely low dynamic impedance allows excellent output regulation even with fluctuating operating current.

The LT1029 will replace an LM136-5 or LM336-5 and simplify circuits using the “minimum temperature coefficient” trim network. The LT1029 does not require this special network to meet its temperature drift specification; these application network components are simply removed. If output trimming is required for initial accuracy, the diodes in the trim network should be replaced with jumpers.

LT, LTC and LT are registered trademarks of Linear Technology Corporation.

TYPICAL APPLICATION

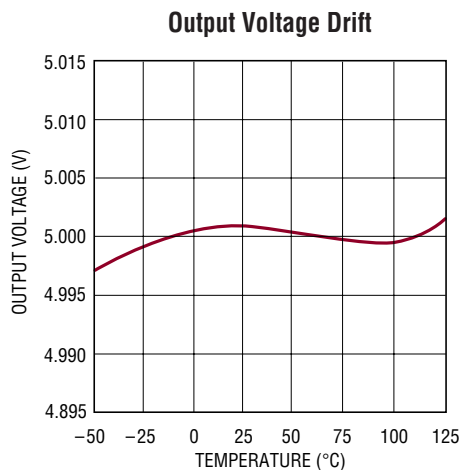
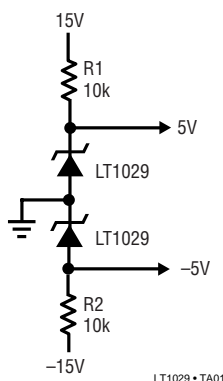

LT1029/LT1029A

ABSOLUTE MAXIMUM RATINGS (Note 1)

Reverse Current	15mA	Storage Temperature	-65°C to 150°C
Forward Current	10mA	Lead Temperature (Soldering, 10 sec).....	300°C
Operating Temperature Range			
LT1029C/LT1029AC	0°C to 70°C		
LT1029M/LT1029AM (OBSOLETE)	-55°C to 125°C		

PACKAGE/ORDER INFORMATION

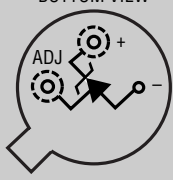
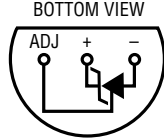
 <p>BOTTOM VIEW</p> <p>H PACKAGE TO-46 METAL CAN $T_{JMAX} = 150^{\circ}\text{C}$, $\theta_{JA} = 440^{\circ}\text{C/W}$, $\theta_{JC} = 80^{\circ}\text{C/W}$</p> <p>OBSOLETE PACKAGE Consider the Z Package as an Alternate Source</p>	ORDER PART NUMBER	 <p>BOTTOM VIEW</p> <p>Z PACKAGE TO-92 PLASTIC $T_{JMAX} = 100^{\circ}\text{C}$, $\theta_{JA} = 160^{\circ}\text{C/W}$</p>	ORDER PART NUMBER
	LT1029AMH LT1029MH LT1029ACH LT1029CH		LT1029ACZ LT1029CZ

Consult LTC Marketing for parts specified with wider operating temperature ranges.

ELECTRICAL CHARACTERISTICS

The ● denotes the specifications which apply over the full operating temperature range, otherwise specifications are $T_A = 25^{\circ}\text{C}$.

PARAMETER	CONDITIONS	MIN	TYP	MAX	UNITS	
Reverse Breakdown Voltage	$I_R = 1\text{mA}$ LT1029AM/LT1029AC	4.99	5.00	5.01	V	
	LT1029M/LT1029C	4.95	5.00	5.05	V	
Reverse Breakdown Change with Current	$700\mu\text{A} \leq I_R \leq 10\text{mA}$		2	5	mV	
		●	3	8	mV	
Reverse Dynamic Impedance	$I_R = 1\text{mA}$		0.2	0.6	Ω	
		●	0.3	1.0	Ω	
Temperature Stability	$I_R = 1\text{mA}$	LT1029AC	●	3	7	mV
		LT1029C	●	5	12	mV
		LT1029AM	●	7	18	mV
		LT1029M	●	10	36	mV
Equivalent Temperature Drift	LT1029AM/LT1029AC	●	8	20	ppm/°C	
		●	12	34	ppm/°C	
		●	15	40	ppm/°C	
Long Term Stability			20		ppm/kHr	
Trim Range		±3	+5, -13		%	

Note 1: Absolute Maximum Ratings are those values beyond which the life of a device may be impaired.

TYPICAL PERFORMANCE CHARACTERISTICS

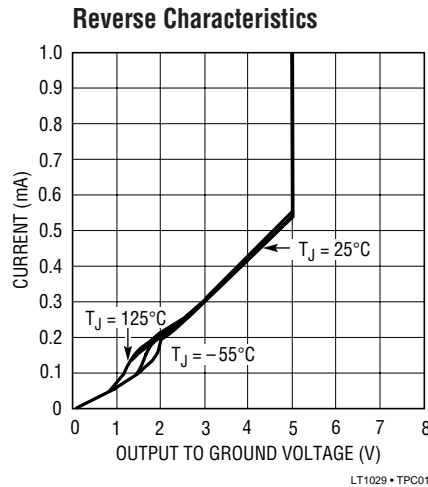

APPLICATIONS INFORMATION

Output Trimming

Output voltage trimming on the LT1029 is nominally accomplished with a potentiometer connected from output to ground with the wiper tied to the trim pin. The LT1029 was made compatible with existing references, so the trim range is large; 5%, – 13%. This large trim range makes precision trimming rather difficult. One solution is to insert resistors in series with both ends of the potentiometer. This has the disadvantage of potentially poor tracking between the fixed resistors and the potentiometer. A second method of reducing trim range is to insert a resistor in series with the wiper of the potentiometer. This works well only for a very small trim range because of the mismatch in TCs between the series resistor and the internal thin film resistors. These film resistors can have a TC as high as 500ppm/°C. That same TC is then transferred to the change in output voltage; a 1% shift in output voltage causes a (500ppm) (1%) = 5ppm/°C change in output voltage drift. The worst case error in initial output voltage for the LT1029A is 0.2% and the LT1029 is 1%, so a series resistor is satisfactory if the output is simply trimmed to nominal value. 1ppm/°C TC shift would be the maximum expected for the LT1029A and 5ppm/°C for the LT1029.

Shunt Capacitance

The LT1029 is stable with all values of shunt capacitance, but values between 300pF and 0.01μF are not recommended because they cause longer settling following a

transient in operating current. A 1μF solid tantalum capacitor is suggested for most situations where bypassing is desirable.

Wide Trim Range (5%, – 13%)

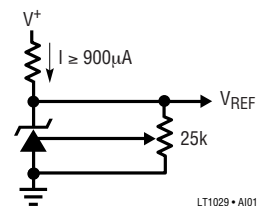

Narrow Trim Range

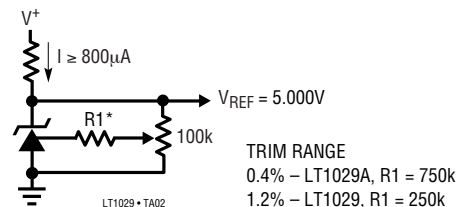

Trimming Output to 5.120V

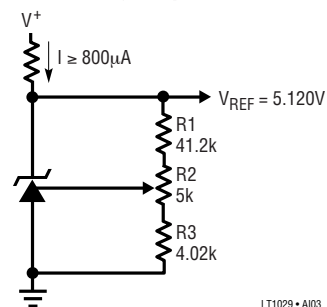

APPLICATIONS INFORMATION

Split ±2.5V References

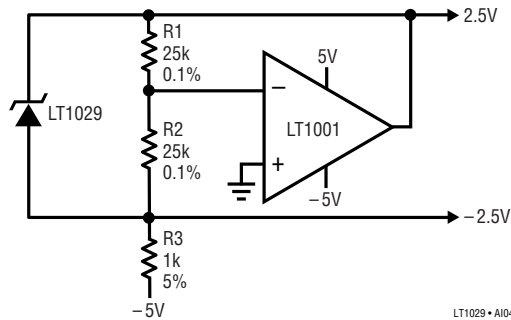

LT1029 • AI04

PACKAGE DESCRIPTION

H Package
2-Lead and 3-Lead TO-46 Metal Can
(Reference LTC DWG # 05-08-1340)

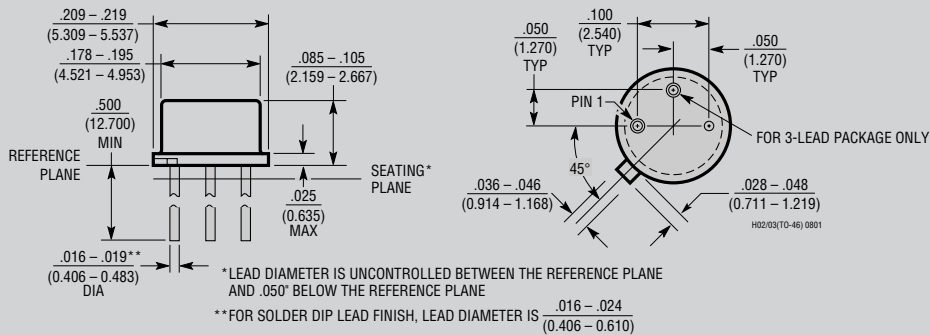

OBSOLETE PACKAGE

Z Package
3-Lead Plastic TO-92 (Similar to TO-226)
(Reference LTC DWG # 05-08-1330)

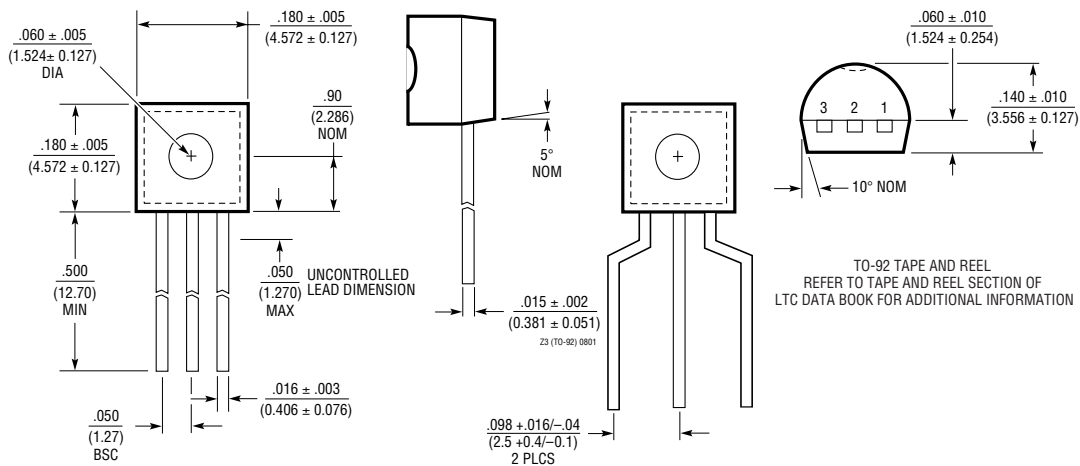

1029afa