

PART NUMBER	SSI-LXMP5011SRC150	REV.	B
DATE	E.C.N. NUMBER AND REVISION COMMENTS		REV.
11.02.01	E.C.N. #10BRDR. & REDRAWN IN 3D.		A
05.13.11	E.C.N. #10BRDR.		B

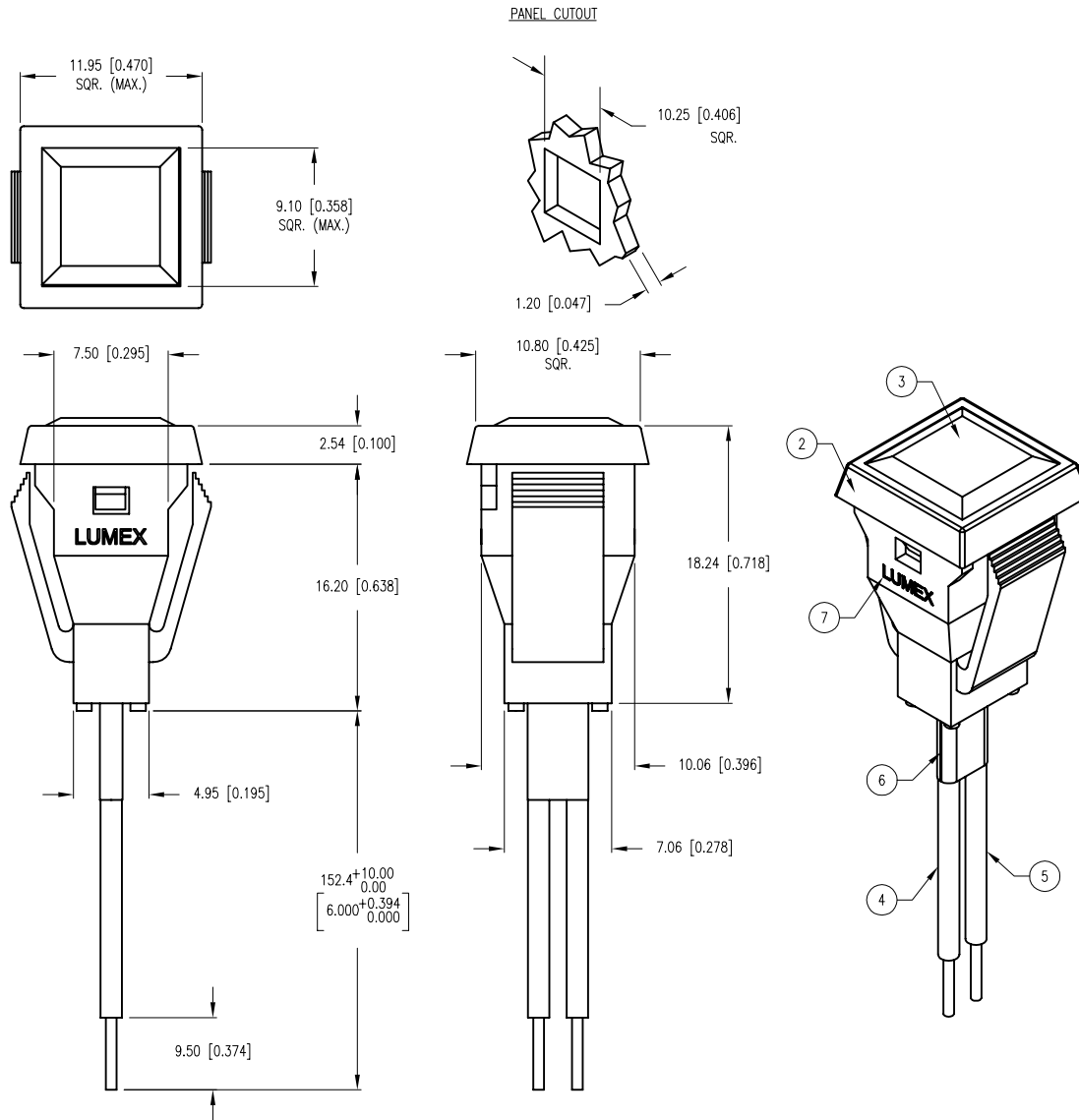

ELECTRO-OPTICAL CHARACTERISTICS T_A=25°C I_f=20mA

PARAMETER	MIN	TYP	MAX	UNITS	TEST COND
PEAK WAVELENGTH		660		nm	
FORWARD VOLTAGE		1.8	2.2	V _f	
REVERSE VOLTAGE	4.0			V _r	I _r =100μA
AXIAL INTENSITY		60		mcd	I _f =20mA
VIEWING ANGLE		60		2x theta	
EMITTED COLOR:	RED				
EPOXY LENS FINISH:	WATER CLEAR				

LIMITS OF SAFE OPERATION AT 25°C

PARAMETER	MAX	UNITS
PEAK FORWARD CURRENT*	150	mA
STEADY CURRENT	30	mA
POWER DISSIPATION	100	mW
DERATE FROM 25°C	-1.2	mW/°C
OPERATING, STORAGE TEMP.	-40 TO +85	°C

* t<10μS

- NOTES:
- SSL-LX4073SRD LED, RED. (INSIDE)
 - SSH-LXMP5011 HOLDER, BLACK.
 - LXP-LXN5011C, WATER CLEAR LENS.
 - ANODE LEAD: LXP-WST24RDT0C, 24 AWG STRANDED, TOP OVERCOAT, RED INSULATION, CUT 160mm LONG, STRIP 4mm & 9.5mm.
 - CATHODE LEAD: LXP-WST24BLT0C, 24 AWG STRANDED, TOP OVERCOAT, BLACK INSULATION, CUT 160mm LONG, STRIP 4mm & 9.5mm.
 - HEAT SHRINK: LXP-HEATSHRINK-4, 1/8" x 1/2". (1 PIECE)
 - 'LUMEX' ON FRONT (ANODE SIDE) OF PART.

*UNLESS OTHERWISE SPECIFIED TOLERANCES PER DECIMAL PRECISION ARE: X=±1 (±0.039), X.X=±0.5 (±0.020), X.XX=±0.25 (±0.010), X.XXX=±0.127 (±0.005). LEAD SIZE=±0.05 (±0.002), LEAD LENGTH=±0.75 (±0.030). MIN= ^{+DECIMAL}_{-0.00} PRECISION MAX.= ^{+0.00}_{-DECIMAL} PRECISION

LUMEX
 Creating LED and LCD Solutions Together™

290 E. HELEN ROAD
 PALATINE, IL 60067-6976
 PHONE: +1.847.359.2790
 FAX: +1.847.359.6538
 WEB: WWW.LUMEX.COM

12mm SQUARE PANEL INDICATOR WITH LENS, 660nm RED LED, WATER CLEAR LENS, 6" WIRE LEADS.

THE SPECIFICATIONS MAY CHANGE AT ANY TIME WITHOUT NOTICE DUE TO NEW MATERIALS OR PRODUCT IMPROVEMENT.

CONFIDENTIAL INFORMATION
 THE INFORMATION CONTAINED IN THIS DOCUMENT IS THE PROPERTY OF LUMEX INC. EXCEPT AS SPECIFICALLY AUTHORIZED IN WRITING BY LUMEX INC., THE HOLDER OF THIS DOCUMENT SHALL KEEP ALL INFORMATION CONTAINED HEREIN CONFIDENTIAL AND SHALL PROTECT SAME IN WHOLE OR IN PART FROM DISCLOSURE AND DISSEMINATION TO ALL THIRD PARTIES.

DATE:	05.13.11	DRAWN BY:	AB
PAGE:	1 OF 1	CHKD BY:	JD
SCALE:	NTS	APRVD BY:	JD
UNIT:	mm [INCH]		Ⓟ