

### DESCRIPTION

The MP8801 is a low-noise, low-dropout linear regulator. It operates from a 2.7V to 6.5V input voltage and regulates the output voltage with 2% accuracy at 2.5V, 2.85V or 3.3V. The internally set output voltage may be overridden with an external resistor divider from 1.25V to 5V.

The MP8801 can supply up to 150mA of load current. The MP8801 features thermal overload protection and is available in a 5-pin TSOT23-5 package.

### FIXED VOLTAGE PART NUMBERS

Part Number	Output Voltage
MP8801DJ-2.5	2.5V
MP8801DJ-2.85	2.85V
MP8801DJ-3.3	3.3V

### EVALUATION BOARD REFERENCE

Board Number	Output*	Dimensions
EV8801DJ-00A	2.85V	2.0"X x 2.0"Y x 0.4"Z

\* Default output voltage adjustable from 1.25V to 5.0V using an external resistor divider.

### FEATURES

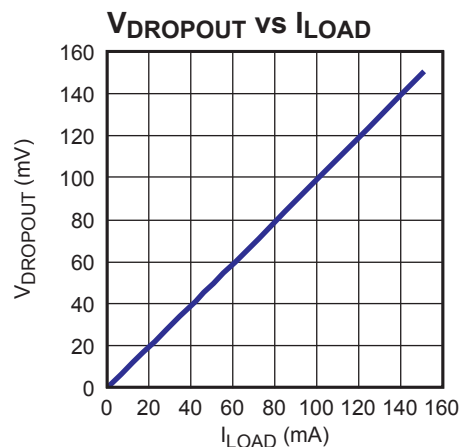
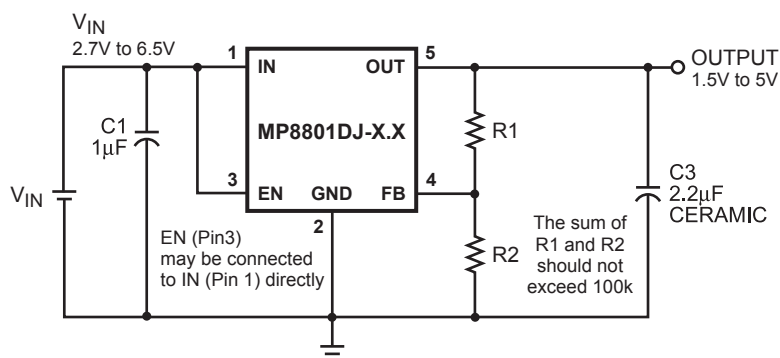
- Low 100mV Dropout at 100mA Output
- 2% Accurate Output Voltage
- Fixed Output Voltage Options of 2.5V, 2.85V or 3.3V
- Adjustable Output Voltage from 1.25V to 5V using an External Resistor Divider
- Up to 6.5V Input Voltage
- High PSRR
  - 70dB at 1kHz
  - 30dB at 1MHz
- Better Than 0.001%/mA Load Regulation
- Stable With Low-ESR Output Capacitor
- Low 125µA Ground Current
- Internal Thermal Protection

### APPLICATIONS

- 802.11 PC Cards
- Mobile Handset PLL Power
- Audio Codec Power

For MPS green status, please visit MPS website under Quality Assurance. "MPS" and "The Future of Analog IC Technology" are Registered Trademarks of Monolithic Power Systems, Inc.

### TYPICAL APPLICATION



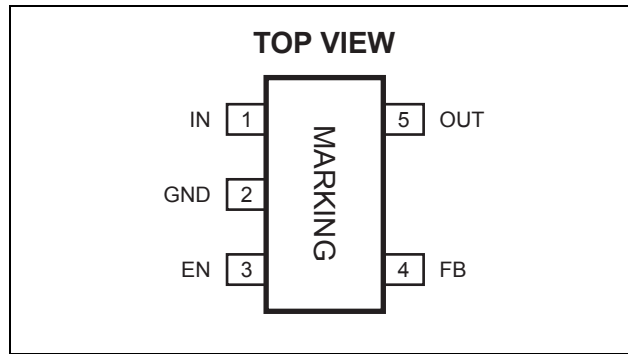
### ORDERING INFORMATION

Part Number*	Package	Top Marking	Free Air Temperature (T <sub>A</sub> )
MP8801DJ-2.5	TSOT23-5		-40°C to +85°C
MP8801DJ-2.85			
MP8801DJ-3.3			

\* For Tape & Reel, add suffix -Z (g. MP8801DJ-2.85-Z).

For RoHS compliant packaging, add suffix -LF (e.g. MP8801DJ-2.85-LF-Z)

### PACKAGE REFERENCE



#### ABSOLUTE MAXIMUM RATINGS <sup>(1)</sup>

IN Supply Voltage .....	-0.3V to +7.0V
FB Voltage .....	-0.3V to V <sub>OUT</sub> + 0.3V
All Other Pins .....	-0.3V to +6V
Continuous Power Dissipation (T <sub>A</sub> = +25°C) <sup>(2)</sup>	0.56W
Junction Temperature .....	150°C
Lead Temperature .....	260°C
Storage Temperature .....	-65°C to +150°C

#### Recommended Operating Conditions <sup>(3)</sup>

Input Voltage .....	2.7V to 6.5V
Output Voltage .....	1.25V to 5V
Load Current .....	150mA Maximum
Maximum Junction Temp. (T <sub>J</sub> ) .....	+125°C

#### Thermal Resistance <sup>(4)</sup>

	$\theta_{JA}$	$\theta_{JC}$
TSOT23-5 .....	220	110 .. °C/W

#### Notes:

- Exceeding these ratings may damage the device.
- The maximum allowable power dissipation is a function of the maximum junction temperature T<sub>J</sub> (MAX), the junction-to-ambient thermal resistance  $\theta_{JA}$ , and the ambient temperature T<sub>A</sub>. The maximum allowable continuous power dissipation at any ambient temperature is calculated by P<sub>D</sub> (MAX) = (T<sub>J</sub> (MAX)-T<sub>A</sub>)/ $\theta_{JA}$ . Exceeding the maximum allowable power dissipation will cause excessive die temperature, and the regulator will go into thermal shutdown. Internal thermal shutdown circuitry protects the device from permanent damage.
- The device is not guaranteed to function outside of its operating conditions.
- Measured on approximately 1" square of 1 oz copper

## ELECTRICAL CHARACTERISTICS

$V_{IN} = 5V$ ,  $T_A = +25^{\circ}C$ , unless otherwise noted.

Parameter	Symbol	Condition	Min	Typ <sup>(5)</sup>	Max	Units	
Operating Voltage		$I_{OUT} = 1mA$	2.7		6.5	V	
Ground Pin Current		$I_{OUT} = 1mA-150mA$		125	150	$\mu A$	
Shutdown Current		$V_{EN} = 0V$ , $V_{IN} = 5V$		0.1	1	$\mu A$	
FB Regulation		Adjustable		1.197	1.222	1.246	V
			$-40^{\circ}C \leq T_A \leq 85^{\circ}C$	1.194	1.222	1.249	
Output Voltage Accuracy	2.5V			2.450	2.500	2.550	V
			$-40^{\circ}C \leq T_A \leq 85^{\circ}C$	2.448	2.500	2.562	
	2.85V			2.793	2.850	2.907	V
			$-40^{\circ}C \leq T_A \leq 85^{\circ}C$	2.779	2.850	2.921	
	3.3V			3.234	3.300	3.366	V
			$-40^{\circ}C \leq T_A \leq 85^{\circ}C$	3.218	3.300	3.382	
Dropout Voltage <sup>(6)</sup>		$I_{OUT} = 150mA$	$V_{OUT} = 3V$		150		mV
			$V_{OUT} = 4V$		125		
Line Regulation		$I_{OUT} = 1mA$ , $V_{IN} = (V_{OUT} + 0.5V)$ to $6.5V$ <sup>(7)</sup>		0.005		%/V	
Load Regulation		$I_{OUT} = 1mA$ to $150mA$ , $V_{IN} = V_{OUT} + 0.5V$ <sup>(7)</sup>		0.001		%/mA	
PSRR		$V_{IN} > V_{OUT} + 0.5V$ , $C3 = 2.2\mu F$ , $V_{IN}(AC) = 100mV$ , $f = 1kHz$ <sup>(5)</sup>		70		dB	
			$V_{IN} > V_{OUT} + 0.5V$ , $C3 = 2.2\mu F$ , $V_{IN}(AC) = 100mV$ , $f = 1MHz$ <sup>(5)</sup>		30		dB
Output Voltage Noise		$f = 1kHz$ , $C2 > 0.1\mu F$ , $I_{OUT} = 1mA$ <sup>(5)</sup>		300		nV/ $\sqrt{Hz}$	
EN Input High Voltage			1.5			V	
EN Input Low Voltage					0.4	V	
EN Input Bias Current		$V_{EN} = 0V$ , $5V$		0.01	1	$\mu A$	
Thermal Protection <sup>(5)</sup>				155		$^{\circ}C$	
Thermal Protection Hysteresis <sup>(5)</sup>				30		$^{\circ}C$	

**Notes:**

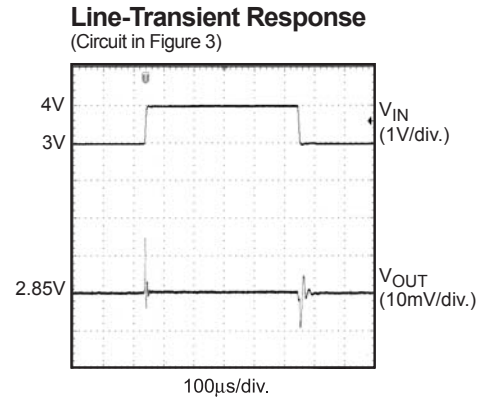
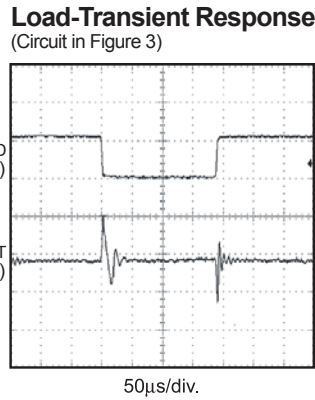
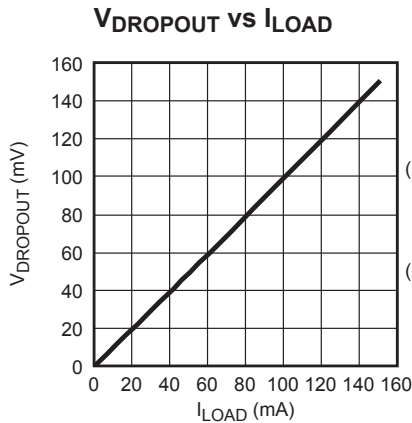
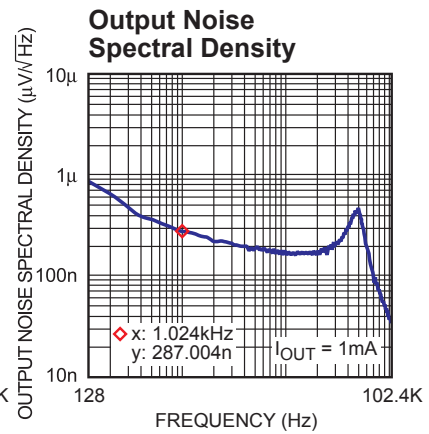
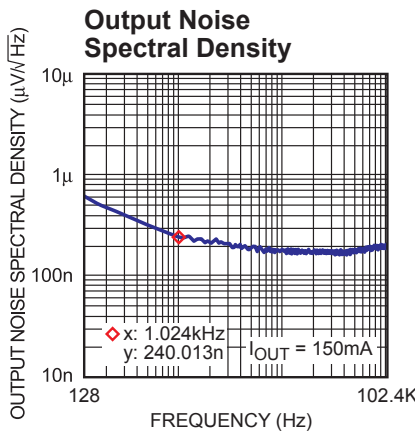
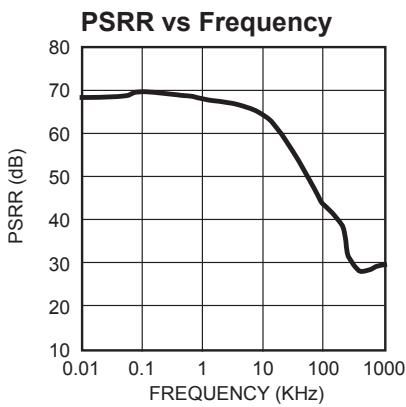
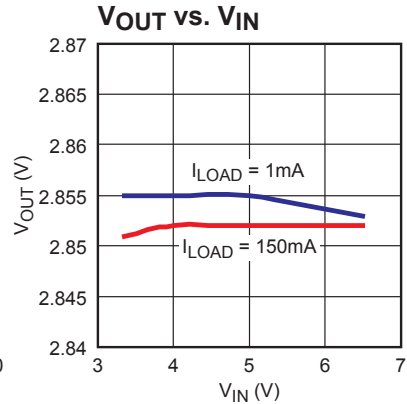
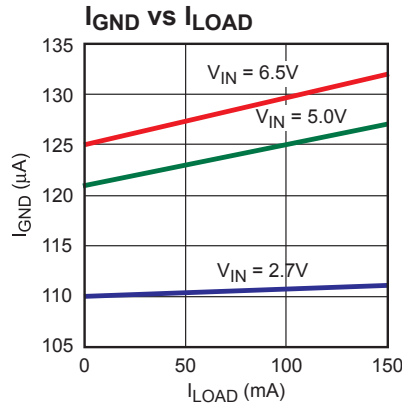
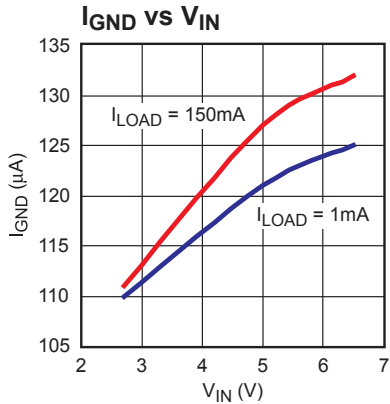
5) Parameter is guaranteed by design, not production tested.

6) Dropout Voltage is defined as the input to output differential when the output voltage drops 1% below its normal value.

7)  $V_{IN} = 2.7V$  for  $V_{OUT} = 1.25V$  to  $2.2V$

## TYPICAL PERFORMANCE CHARACTERISTICS

$V_{IN} = 4.5V$ ,  $V_{OUT} = 2.85V$ ,  $C1 = 1\mu F$ ,  $C2 = 0.1\mu F$ ,  $C3 = 2.2\mu F$ ,  $T_A = +25^\circ C$  unless otherwise noted.



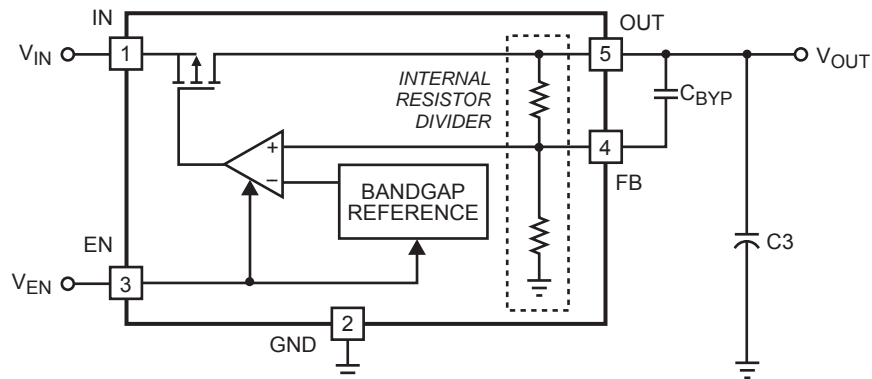
## PIN FUNCTIONS

Pin #	Name	Description
1	IN	Power Source Input. IN supplies the internal power to the MP8801 and is the source of the pass transistor. Bypass IN to GND with a 1µF or greater capacitor.
2	GND	Ground.
3	EN	Enable Input. Drive EN high to turn on the MP8801; low to turn it off. For automatic startup, connect EN to IN.
4	FB	Feedback Input. Connect a resistive voltage divider from OUT to FB to set the output voltage. The OUT feedback threshold is 1.222V.
5	OUT	Regulator Output. OUT is the output of the linear regulator. Bypass OUT to GND with a 1µF or greater capacitor.

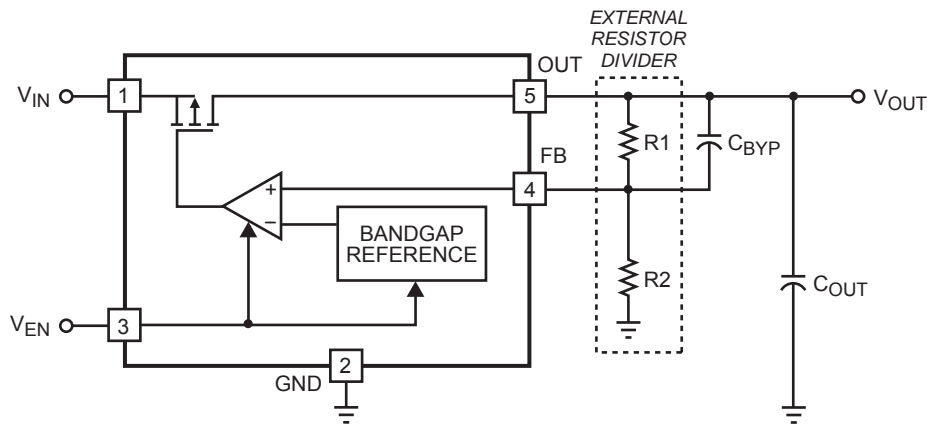
## OPERATION

The MP8801 is a low-current, low-noise, high-PSRR, low-dropout linear regulator. It is intended for use in devices that require very low noise power supplies and high-PSRR such as PLL VCO supplies for mobile handsets and 802.11 PC Cards, as well as audio codecs and microphones. The MP8801 uses a PMOS pass

element and features internal thermal shutdown. The normally fixed output MP8801 may be converted to an adjustable output device by applying a resistor divider network as shown in Figure 2. An optional feed-forward capacitor,  $C_{BYP}$ , may be added for an improved transient response.



**Figure 1—Ultra-Low-Noise Fixed Output Regulator**



**Figure 2—Ultra-Low-Noise Adjustable Regulator:  $V_{OUT} = V_{FB}(1+(R1/R2))$**

## APPLICATION INFORMATION

### Setting the Output Voltage

The fixed output voltage of the MP8801DJ is set to 2.5V, 2.85V or 3.3V, depending on the internal resistor divider (Figure 1). You can also adjust the output voltage by using an external resistor divider (R1 and R2 in Figure 2). However, the sum of R1 and R2 should not exceed 100kΩ in order to minimize the impact of the internal resistor divider. For an accurate output-voltage setting, use 10kΩ (±1%) for the low-side resistor R2 of the voltage divider, while the high-side resistor R1 can be determined by the equation:

$$R1 = R2 \times \left( \frac{V_{OUT} - V_{FB}}{V_{FB}} \right)$$

Where  $V_{FB}$  is the OUT feedback threshold voltage equal to 1.222V.

Example: For 2.5V Output

$$R1 = \frac{2.5V - 1.222V}{\left( \frac{1.222V}{10k\Omega} \right)} = 10.41k\Omega$$

You can select a standard 10.5kΩ (±1%) resistor for R1.

The following table lists the selected R1 values for some typical output voltages:

**Table 1—Adjustable Output Voltage R1 Values**

V <sub>OUT</sub> (V)	R1 (Ω)	R2 (Ω)
1.25	232	10k
1.5	2.26k	
1.8	4.75k	
2	6.34k	
2.5	10.5k	
2.8	13k	
3	14.7k	
3.3	16.9k	
4	22.6k	
5	30.9k	

In Figures 3 and 4, C2 is added for an improved transient response.

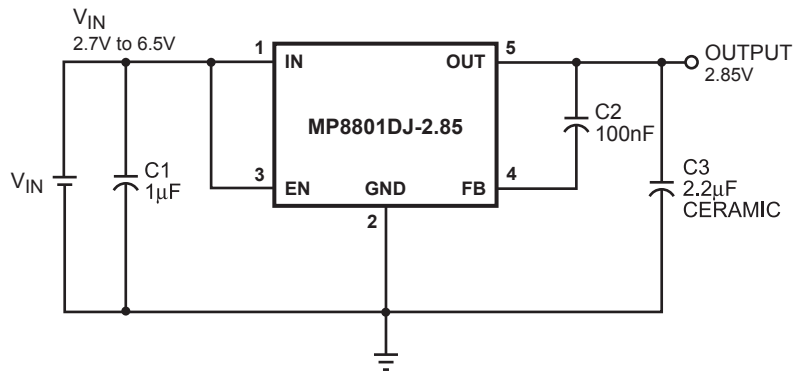
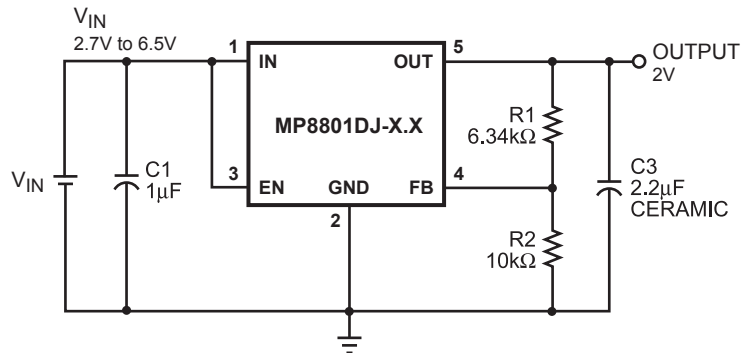
### Input Capacitor Selection

For proper operation, place a ceramic capacitor (C1) between 1μF and 10μF of dielectric type X5R or X7R between the input pin and ground. Larger values in this range will help improve line transient response at the drawback of increased size.

### Output Capacitor Selection

For stable operation, use a ceramic capacitor (C3) of type X5R or X7R between 1μF and 10μF. Larger values in this range will help improve load transient response and reduce noise with the drawback of increased size. Output capacitors of other dielectric types may be used, but are not recommended as their capacitance can deviate greatly from their rated value over temperature.

To improve load transient response, add a small ceramic (X5R, X7R or Y5V dielectric) 100nF feed forward capacitor in parallel with R1. The feed forward capacitor is not required for stable operation.

**TYPICAL APPLICATION CIRCUIT**

**Figure 3—Typical Application Circuit (Fixed)**

**Figure 4—Typical Application Circuit (Adjustable)**

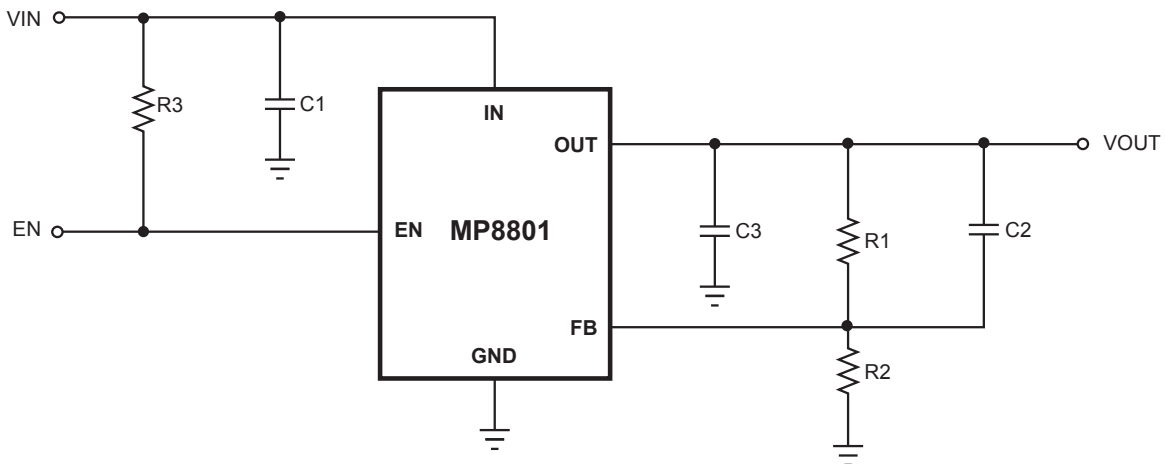
## PCB LAYOUT GUIDE

PCB layout is very important to achieve good regulation, ripple rejection, transient response and thermal performance. It is highly recommended to duplicate EVB layout for optimum performance.

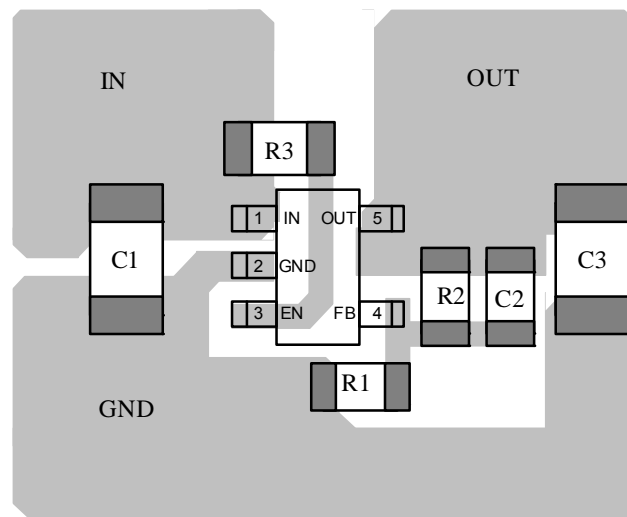
If change is necessary, please follow these guidelines and take figure 6 for reference.

1) Input and output bypass ceramic capacitors are suggested to be put close to the IN Pin and OUT Pin respectively.

- 2) Ensure all feedback connections are short and direct. Place the feedback resistors and compensation components as close to the chip as possible.
- 3) Connect IN, OUT and especially GND respectively to a large copper area to cool the chip to improve thermal performance and long-term reliability.

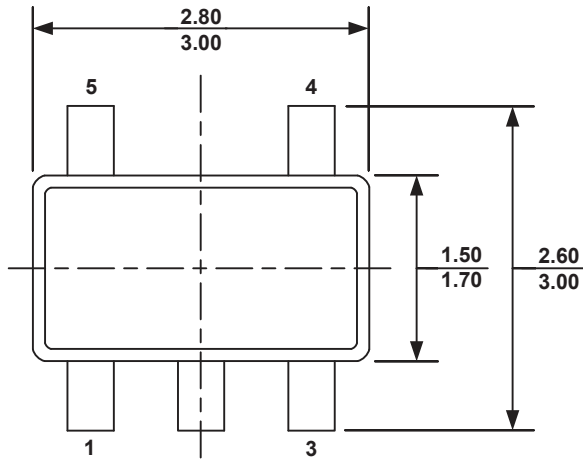
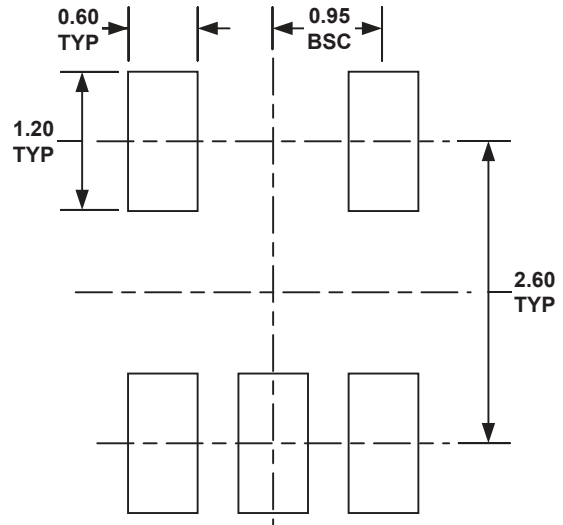
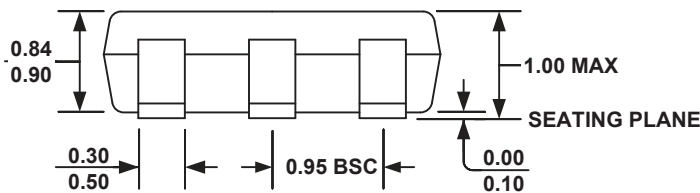
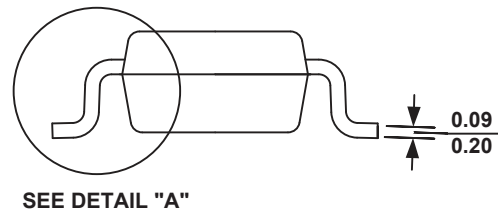
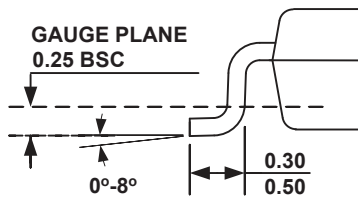


**Figure 5 —Typical Application Circuit**



**FIGURE 6 —TOP LAYER**



**PACKAGE INFORMATION**
**TSOT23-5**

**TOP VIEW**

**RECOMMENDED LAND PATTERN**

**FRONT VIEW**

**SIDE VIEW**

**DETAIL A**
**NOTE:**

- 1) ALL DIMENSIONS ARE IN MILLIMETERS.
- 2) PACKAGE LENGTH DOES NOT INCLUDE MOLD FLASH, PROTRUSION OR GATE BURR.
- 3) PACKAGE WIDTH DOES NOT INCLUDE INTERLEAD FLASH OR PROTRUSION.
- 4) LEAD COPLANARITY (BOTTOM OF LEADS AFTER FORMING) SHALL BE 0.10 MILLIMETERS MAX.
- 5) DRAWING CONFORMS TO JEDEC MO-193, VARIATION AA.
- 6) DRAWING IS NOT TO SCALE.

**NOTICE:** The information in this document is subject to change without notice. Users should warrant and guarantee that third party Intellectual Property rights are not infringed upon when integrating MPS products into any application. MPS will not assume any legal responsibility for any said applications.