

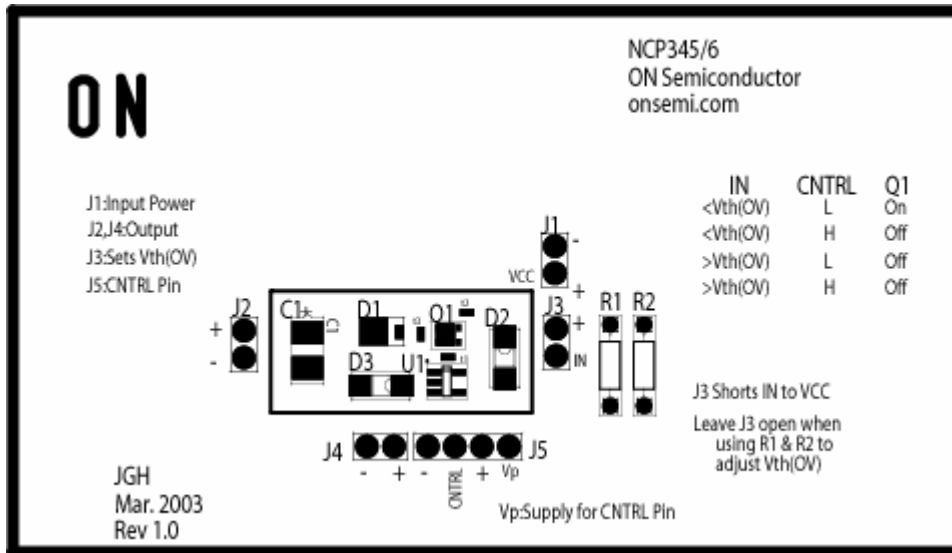

## Test Procedure for the NCP345/6 Evaluation Board

8/27/03



**Figure 1: NCP345/6 Demo Board Assembly Drawing**

Refer to Table 1 for bolded test values in the following procedure.

- 1) Connect jumper to J3.
- 2) Connect jumpers between CNTRL and – pins on J5.
- 3) Connect 50 Ohms to J2 if D3 is unpopulated, otherwise connect to J4.
- 4) Apply **V1** to J1 + and – pins.
- 5) Measure voltage at J2 if D3 is unpopulated, otherwise connect to J4. It should equal **V2**.
- 6) Apply **V3** to J1 + and – pins.
- 7) Wait 1 second.
- 8) Measure voltage at J2 if D3 is unpopulated, otherwise connect to J4. It should equal **V4**.
- 9) Apply **V1** to J1 + and – pins.
- 10) Apply **V5** between Vp on J5 and any open - pin on the board.
- 11) Connect jumper from step (2) between the CNTRL and + pins on J5.
- 12) Measure voltage at J2 if D3 is unpopulated, otherwise connect to J4. It should equal **V4**.

**Table 1: Test Values**

	NCP345SNT1	NCP346SN1T1	NCP346SN2T1	Unit
<b>V1</b>	6	4	5	V
<b>V2*</b>	6	4	5	V
<b>V3</b>	8	5	6	V
<b>V4**</b>	0	0	0	V
<b>V5</b>	2	2	2	V

\* This is the power supply voltage minus the voltage drops across Q1 and D1. It might measure slightly lower than V1.

\*\* Since C1 is a large capacitor a load (specified in step (3)) is required for the voltage to decay to 0V in a timely manner for functional testing.