

# OVM9724 720p HD CameraCubeChip™ product brief



## Industry's Most Compact Front-Facing HD Camera for Smartphones, Tablets, Notebooks and Ultrabooks



available in  
a lead-free  
package

OmniVision's ultra-compact OVM9724 CameraCubeChip™ captures 720p high definition (HD) video at 30 frames per second (fps) in an industry-leading miniaturized module of 3.9 x 2.9 x 2.3 mm. Because the OVM9724 CameraCubeChip is a reflowable all-in-one camera drop-in solution, the need for additional components is eliminated and manufacturing is significantly streamlined.

The low-power 1/9-inch OVM9724 utilizes OmniVision's powerful OmniBSI+™ pixel architecture to enable high quality color images and fast frame 720p HD video at 30 fps or cropped VGA at 60 fps. This combination of

high-performance and small form factor allows HD cameras to be integrated into ultra-slim, narrow-bezel devices, making it an attractive solution for next generation smartphones, tablets, notebooks and Ultrabooks™.

The OVM9724 provides full-frame, sub sampled or windowed 8- and 10-bit images. All required image processing functions, including exposure control and defective pixel cancelling are programmable through the serial camera control bus (SCCB) interface.

Find out more at [www.ovt.com](http://www.ovt.com).



## Applications

- Phones
- Security and Surveillance
- Wearable Devices
- Toys and Games

## Product Features

- MIPI and D-PHY specification (contains one clock lane and one data lane) with a maximum of 400 Mbps data transfer rate
- low operating voltage and low power consumption for embedded portable applications
- high sensitivity and low dark current for low-light conditions
- supports global analog gain
- supports free-running clock and gated clock
- supports down sample mode and VarioPixel\*
- auto black level calibration
- defect correction capability

# OVM9724



## Ordering Information

- **OVM9724-RYDA** (color, lead-free, CameraCubeChip™ with metal can)
- **OVM9724-RADA** (color, lead-free, CameraCubeChip™ with black coating)

## Product Specifications

- **active array size:** 1280 x 720
- **power supply:**
  - core: 1.5V
  - analog: 2.8V
  - I/O: 1.8V
- **power requirements:**
  - active: 55 mA
  - hardware standby: 60  $\mu$ A
  - XSHUTDOWN: 20  $\mu$ A
- **temperature range:**
  - operating: -30°C to +70°C junction temperature
  - stable image: 0°C to +50°C junction temperature
- **output formats:** 10-bit RAW RGB data
- **lens size:** 1/9"
- **diagonal field of view (FOV):** 65°
- **f no.:** 2.8
- **focal length:** 1.66 mm
- **input clock frequency:** 6 - 27 MHz
- **max S/N ratio:** 36.2 dB
- **dynamic range:** 70.4 dB @ 8x gain
- **maximum image transfer rate:** 30 fps
- **sensitivity:** 740 mV/lux-sec
- **scan mode:** progressive
- **maximum exposure interval:** 760 x  $t_{row}$
- **pixel size:** 1.4  $\mu$ m x 1.4  $\mu$ m
- **dark current:** 80 mV/s @ 50°C junction temperature
- **image area:** 1840  $\mu$ m x 1040  $\mu$ m
- **package dimensions (including ball height):**
  - RYDA: 4180 x 3280 x 2610  $\mu$ m
  - RADA: 3900 x 2890 x 2340  $\mu$ m

## Functional Block Diagram

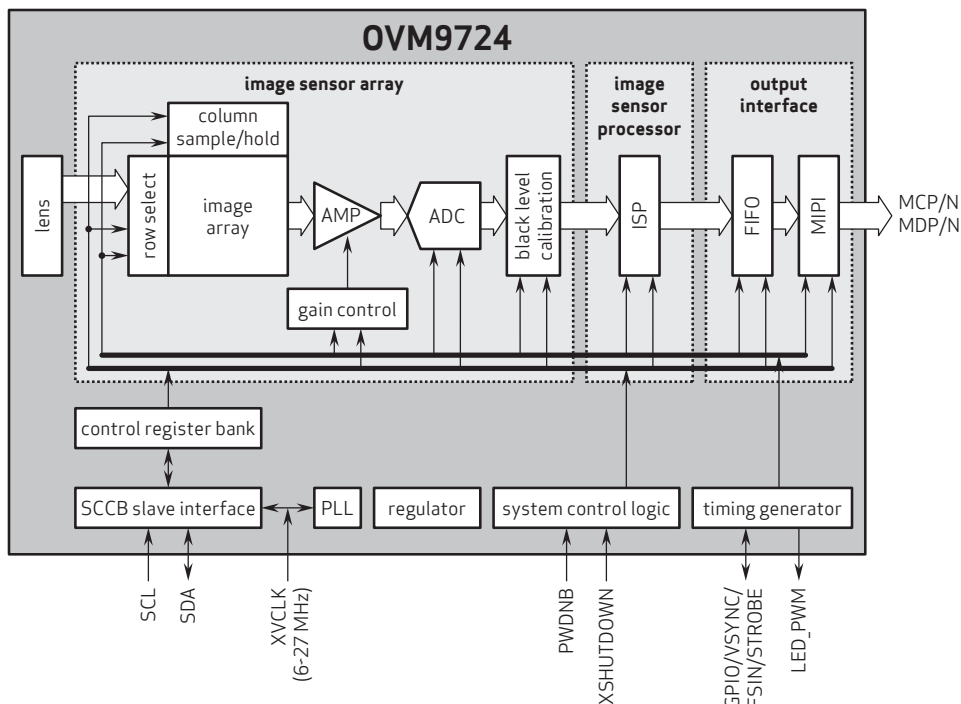

4275 Burton Drive  
Santa Clara, CA 95054  
USA

Tel: + 1 408 567 3000  
Fax: + 1 408 567 3001  
www.ovt.com

OmniVision reserves the right to make changes to their products or to discontinue any product or service without further notice. OmniVision, the OmniVision logo and VarioPixel are registered trademarks of OmniVision Technologies, Inc. CameraCubeChip and OmniBSI+ are trademarks of OmniVision Technologies, Inc. All other trademarks are the property of their respective owners.



OmniVision