

# **MC9S12DT256**

## **Device User Guide**

### **V03.07**

**Covers also**

**MC9S12A256, MC9S12DJ256**  
**MC9S12DG256,**

**Original Release Date: 24 March 2003**  
**Revised: 12 October 2005**  
**Motorola, Inc**

Motorola reserves the right to make changes without further notice to any products herein to improve reliability, function or design. Motorola does not assume any liability arising out of the application or use of any product or circuit described herein; neither does it convey any license under its patent rights nor the rights of others. Motorola products are not designed, intended, or authorized for use as components in systems intended for surgical implant into the body, or other applications intended to support or sustain life, or for any other application in which the failure of the Motorola product could create a situation where personal injury or death may occur. Should Buyer purchase or use Motorola products for any such unintended or unauthorized application, Buyer shall indemnify and hold Motorola and its officers, employees, subsidiaries, affiliates, and distributors harmless against all claims, costs, damages, and expenses, and reasonable attorney fees arising out of, directly or indirectly, any claim of personal injury or death associated with such unintended or unauthorized use, even if such claim alleges that Motorola was negligent regarding the design or manufacture of the part.

# Revision History

Version Number	Revision Date	Effective Date	Author	Description of Changes
V03.00	24 March 2003			Initial version for Maskset L91N , based on MC9S12DP256B V02.11.
V03.01	30 June 2003			<ul style="list-style-type: none"> <li>• added new HCS12 core documentation</li> <li>• added cumulative program/erase cycle limitation to Table A-12 for EEPROM</li> <li>• updated Table 0-2 Document References</li> </ul>
V03.02	24 July 2003			<ul style="list-style-type: none"> <li>• removed cumulative program/erase cycle limitation from Table A-12 for EEPROM</li> <li>• added LRAE generic load and execute info to section 15</li> </ul>
V03.03	26 July 2003			<ul style="list-style-type: none"> <li>• Added MC9S12DT256 in QFP 80 to Table 0-1</li> </ul>
V03.04	15 March 2004			<ul style="list-style-type: none"> <li>• Added Masksets 0L01Y and 4L91N</li> </ul>
V03.05	4 April 2005			<ul style="list-style-type: none"> <li>• Changed NVM data retention specification <b>Table A-12</b></li> </ul>
V03.06	12 Oct 2005			<ul style="list-style-type: none"> <li>• Corrected Flash Burst Programming Time <b>Table A-11</b>,</li> <li>• NVM Reliability Spec <b>Table A-12</b> ,<b>Figure A-2</b></li> </ul>
V03.07	02 Jan 2006			<ul style="list-style-type: none"> <li>• Corrected Flash Burst Programming Time <b>Table A-11</b>,</li> </ul>

Motorola reserves the right to make changes without further notice to any products herein to improve reliability, function or design. Motorola does not assume any liability arising out of the application or use of any product or circuit described herein; neither does it convey any license under its patent rights nor the rights of others. Motorola products are not designed, intended, or authorized for use as components in systems intended for surgical implant into the body, or other applications intended to support or sustain life, or for any other application in which the failure of the Motorola product could create a situation where personal injury or death may occur. Should Buyer purchase or use Motorola products for any such unintended or unauthorized application, Buyer shall indemnify and hold Motorola and its officers, employees, subsidiaries, affiliates, and distributors harmless against all claims, costs, damages, and expenses, and reasonable attorney fees arising out of, directly or indirectly, any claim of personal injury or death associated with such unintended or unauthorized use, even if such claim alleges that Motorola was negligent regarding the design or manufacture of the part.





# Table of Contents

## Section 1 IntroductionMC9S12DT256

1.1	Overview . . . . .	19
1.2	Features . . . . .	19
1.3	Modes of Operation . . . . .	21
1.4	Block Diagram . . . . .	22
1.5	Device Memory Map . . . . .	24
1.6	Detailed Register Map . . . . .	27
1.7	Part ID Assignments . . . . .	50

## Section 2 Signal Description

2.1	Device Pinout . . . . .	51
2.2	Signal Properties Summary . . . . .	53
2.3	Detailed Signal Descriptions . . . . .	56
2.3.1	EXTAL, XTAL — Oscillator Pins . . . . .	56
2.3.2	RESET — External Reset Pin . . . . .	56
2.3.3	TEST — Test Pin . . . . .	57
2.3.4	VREGEN — Voltage Regulator Enable Pin . . . . .	57
2.3.5	XFC — PLL Loop Filter Pin . . . . .	57
2.3.6	BKGD / TAGHI / MODC — Background Debug, Tag High, and Mode Pin . . . . .	57
2.3.7	PAD15 / AN15 / ETRIG1 — Port AD Input Pin of ATD1 . . . . .	57
2.3.8	PAD[14:08] / AN[14:08] — Port AD Input Pins of ATD1 . . . . .	57
2.3.9	PAD7 / AN07 / ETRIG0 — Port AD Input Pin of ATD0 . . . . .	58
2.3.10	PAD[06:00] / AN[06:00] — Port AD Input Pins of ATD0 . . . . .	58
2.3.11	PA[7:0] / ADDR[15:8] / DATA[15:8] — Port A I/O Pins . . . . .	58
2.3.12	PB[7:0] / ADDR[7:0] / DATA[7:0] — Port B I/O Pins . . . . .	58
2.3.13	PE7 / NOACC / XCLKS — Port E I/O Pin 7 . . . . .	58
2.3.14	PE6 / MODB / IPIPE1 — Port E I/O Pin 6 . . . . .	60
2.3.15	PE5 / MODA / IPIPE0 — Port E I/O Pin 5 . . . . .	60
2.3.16	PE4 / ECLK — Port E I/O Pin 4 . . . . .	60
2.3.17	PE3 / LSTRB / TAGLO — Port E I/O Pin 3 . . . . .	60
2.3.18	PE2 / R/W — Port E I/O Pin 2 . . . . .	61
2.3.19	PE1 / IRQ — Port E Input Pin 1 . . . . .	61
2.3.20	PE0 / XIRQ — Port E Input Pin 0 . . . . .	61

2.3.21	PH7 / KWH7 / SS2 — Port H I/O Pin 7	.61
2.3.22	PH6 / KWH6 / SCK2 — Port H I/O Pin 6	.61
2.3.23	PH5 / KWH5 / MOSI2 — Port H I/O Pin 5	.61
2.3.24	PH4 / KWH4 / MISO2 — Port H I/O Pin 2	.61
2.3.25	PH3 / KWH3 / SS1 — Port H I/O Pin 3	.61
2.3.26	PH2 / KWH2 / SCK1 — Port H I/O Pin 2	.62
2.3.27	PH1 / KWH1 / MOSI1 — Port H I/O Pin 1	.62
2.3.28	PH0 / KWH0 / MISO1 — Port H I/O Pin 0	.62
2.3.29	PJ7 / KWJ7 / TXCAN4 / SCL — PORT J I/O Pin 7	.62
2.3.30	PJ6 / KWJ6 / RXCAN4 / SDA — PORT J I/O Pin 6	.62
2.3.31	PJ[1:0] / KWJ[1:0] — Port J I/O Pins [1:0]	.62
2.3.32	PK7 / ECS / ROMONE — Port K I/O Pin 7	.62
2.3.33	PK[5:0] / XADDR[19:14] — Port K I/O Pins [5:0]	.63
2.3.34	PM7 / TXCAN4 — Port M I/O Pin 7	.63
2.3.35	PM6 / RXCAN4 — Port M I/O Pin 6	.63
2.3.36	PM5 / TXCAN0 / TXCAN4 / SCK0 — Port M I/O Pin 5	.63
2.3.37	PM4 / RXCAN0 / RXCAN4 / MOSI0 — Port M I/O Pin 4	.63
2.3.38	PM3 / TXCAN1 / TXCAN0 / SS0 — Port M I/O Pin 3	.63
2.3.39	PM2 / RXCAN1 / RXCAN0 / MISO0 — Port M I/O Pin 2	.63
2.3.40	PM1 / TXCAN0 / TXB — Port M I/O Pin 1	.64
2.3.41	PM0 / RXCAN0 / RXB — Port M I/O Pin 0	.64
2.3.42	PP7 / KWP7 / PWM7 / SCK2 — Port P I/O Pin 7	.64
2.3.43	PP6 / KWP6 / PWM6 / SS2 — Port P I/O Pin 6	.64
2.3.44	PP5 / KWP5 / PWM5 / MOSI2 — Port P I/O Pin 5	.64
2.3.45	PP4 / KWP4 / PWM4 / MISO2 — Port P I/O Pin 4	.64
2.3.46	PP3 / KWP3 / PWM3 / SS1 — Port P I/O Pin 3	.64
2.3.47	PP2 / KWP2 / PWM2 / SCK1 — Port P I/O Pin 2	.65
2.3.48	PP1 / KWP1 / PWM1 / MOSI1 — Port P I/O Pin 1	.65
2.3.49	PP0 / KWP0 / PWM0 / MISO1 — Port P I/O Pin 0	.65
2.3.50	PS7 / SS0 — Port S I/O Pin 7	.65
2.3.51	PS6 / SCK0 — Port S I/O Pin 6	.65
2.3.52	PS5 / MOSI0 — Port S I/O Pin 5	.65
2.3.53	PS4 / MISO0 — Port S I/O Pin 4	.65
2.3.54	PS3 / TXD1 — Port S I/O Pin 3	.65
2.3.55	PS2 / RXD1 — Port S I/O Pin 2	.66
2.3.56	PS1 / TXD0 — Port S I/O Pin 1	.66

2.3.57	PS0 / RXD0 — Port S I/O Pin 0 . . . . .	66
2.3.58	PT[7:0] / IOC[7:0] — Port T I/O Pins [7:0] . . . . .	66
2.4	Power Supply Pins . . . . .	66
2.4.1	VDDX,VSSX — Power & Ground Pins for I/O Drivers . . . . .	66
2.4.2	VDDR, VSSR — Power & Ground Pins for I/O Drivers & for Internal Voltage Regulator 66	
2.4.3	VDD1, VDD2, VSS1, VSS2 — Core Power Pins . . . . .	67
2.4.4	VDDA, VSSA — Power Supply Pins for ATD and VREG . . . . .	67
2.4.5	VRH, VRL — ATD Reference Voltage Input Pins . . . . .	67
2.4.6	VDDPLL, VSSPLL — Power Supply Pins for PLL . . . . .	67
2.4.7	VREGEN — On Chip Voltage Regulator Enable . . . . .	68

## Section 3 System Clock Description

3.1	Overview . . . . .	69
-----	--------------------	----

## Section 4 Modes of Operation

4.1	Overview . . . . .	71
4.2	Chip Configuration Summary . . . . .	71
4.3	Security . . . . .	72
4.3.1	Securing the Microcontroller . . . . .	72
4.3.2	Operation of the Secured Microcontroller . . . . .	72
4.3.3	Unsecuring the Microcontroller . . . . .	73
4.4	Low Power Modes . . . . .	73
4.4.1	Stop . . . . .	73
4.4.2	Pseudo Stop . . . . .	73
4.4.3	Wait . . . . .	73
4.4.4	Run . . . . .	74

## Section 5 Resets and Interrupts

5.1	Overview . . . . .	75
5.2	Vectors . . . . .	75
5.2.1	Vector Table . . . . .	75
5.3	Effects of Reset . . . . .	77
5.3.1	I/O pins . . . . .	77
5.3.2	Memory . . . . .	77

## Section 6 HCS12 Core Block Description

6.1	CPU12 Block Description . . . . .	79
6.2	HCS12 Module Mapping Control (MMC) Block Description . . . . .	79
6.2.1	Device specific information . . . . .	79
6.3	HCS12 Multiplexed External Bus Interface (MEBI) Block Description . . . . .	79
6.3.1	Device specific information . . . . .	79
6.4	HCS12 Interrupt (INT) Block description . . . . .	79
6.5	HCS12 Background Debug (BDM) Block Description . . . . .	79
6.6	HCS12 Breakpoint (BKP) Block Description . . . . .	80

## **Section 7 Clock and Reset Generator (CRG) Block Description**

7.1	Device-specific information. . . . .	80
7.1.1	XCLKS . . . . .	80

## **Section 8 Enhanced Capture Timer (ECT) Block Description**

## **Section 9 Analog to Digital Converter (ATD) Block Description**

## **Section 10 Inter-IC Bus (IIC) Block Description**

## **Section 11 Serial Communications Interface (SCI) Block Description**

## **Section 12 Serial Peripheral Interface (SPI) Block Description**

## **Section 13 J1850 (BDLC) Block Description**

## **Section 14 Pulse Width Modulator (PWM) Block Description**

## **Section 15 Flash EEPROM 256K Block Description**

## **Section 16 EEPROM 4K Block Description**

## **Section 17 RAM Block Description**

## **Section 18 MSCAN Block Description**

## **Section 19 Port Integration Module (PIM) Block Description**

## **Section 20 Voltage Regulator (VREG) Block Description**



## Appendix A Electrical Characteristics

A.1	General	89
A.1.1	Parameter Classification	89
A.1.2	Power Supply	89
A.1.3	Pins	90
A.1.4	Current Injection	91
A.1.5	Absolute Maximum Ratings	91
A.1.6	ESD Protection and Latch-up Immunity	92
A.1.7	Operating Conditions	93
A.1.8	Power Dissipation and Thermal Characteristics	93
A.1.9	I/O Characteristics	95
A.1.10	Supply Currents	97
A.2	ATD Characteristics	99
A.2.1	ATD Operating Characteristics	99
A.2.2	Factors influencing accuracy	99
A.2.3	ATD accuracy	101
A.3	NVM, Flash and EEPROM	103
A.3.1	NVM timing	103
A.3.2	NVM Reliability	105
A.4	Voltage Regulator	109
A.5	Reset, Oscillator and PLL	111
A.5.1	Startup	111
A.5.2	Oscillator	112
A.5.3	Phase Locked Loop	113
A.6	MSCAN	117
A.7	SPI	119
A.7.1	Master Mode	119
A.7.2	Slave Mode	121
A.8	External Bus Timing	123
A.8.1	General Muxed Bus Timing	123

## Appendix B Package Information

B.1	General	127
B.2	112-pin LQFP package	128
B.3	80-pin QFP package	129



# List of Figures

Figure 0-1	Order Partnumber Example . . . . .	15
Figure 1-1	MC9S12DT256 Block Diagram . . . . .	23
Figure 1-2	MC9S12DT256 Memory Map . . . . .	26
Figure 2-1	Pin Assignments in 112-pin LQFP. . . . .	52
Figure 2-2	Pin Assignments in 80-pin QFP for MC9S12DJ256 . . . . .	53
Figure 2-3	PLL Loop Filter Connections . . . . .	57
Figure 2-4	Colpitts Oscillator Connections (PE7=1) . . . . .	59
Figure 2-5	Pierce Oscillator Connections (PE7=0) . . . . .	59
Figure 2-6	External Clock Connections (PE7=0) . . . . .	60
Figure 3-1	Clock Connections. . . . .	69
Figure 20-1	Recommended PCB Layout for 112LQFP Colpitts Oscillator . . . . .	84
Figure 20-2	Recommended PCB Layout for 80QFP Colpitts Oscillator . . . . .	85
Figure 20-3	Recommended PCB Layout for 112LQFP Pierce Oscillator . . . . .	86
Figure 20-4	Recommended PCB Layout for 80QFP Pierce Oscillator . . . . .	87
Figure A-1	ATD Accuracy Definitions . . . . .	102
Figure A-2	Typical Endurance vs Temperature. . . . .	107
Figure A-3	Basic PLL functional diagram . . . . .	113
Figure A-4	Jitter Definitions . . . . .	115
Figure A-5	Maximum bus clock jitter approximation . . . . .	115
Figure A-6	SPI Master Timing (CPHA=0) . . . . .	119
Figure A-7	SPI Master Timing (CPHA=1) . . . . .	120
Figure A-8	SPI Slave Timing (CPHA=0) . . . . .	121
Figure A-9	SPI Slave Timing (CPHA=1) . . . . .	122
Figure A-10	General External Bus Timing. . . . .	124
Figure B-1	112-pin LQFP mechanical dimensions (case no. 987) . . . . .	128
Figure B-2	80-pin QFP Mechanical Dimensions (case no. 841B). . . . .	129



## List of Tables

Table 0-1	Derivative Differences . . . . .	15
Table 0-2	Document References . . . . .	17
Table 0-3	Specification Change Summary for Maskset L91N . . . . .	17
Table 1-1	Device Memory Map . . . . .	24
Table 1-2	Detailed MSCAN Foreground Receive and Transmit Buffer Layout. . . . .	43
Table 1-3	Assigned Part ID Numbers . . . . .	50
Table 1-4	Memory size registers . . . . .	50
Table 2-1	Signal Properties . . . . .	53
Table 2-2	MC9S12DP256 Power and Ground Connection Summary . . . . .	67
Table 4-1	Mode Selection . . . . .	71
Table 4-2	Clock Selection Based on PE7 . . . . .	71
Table 4-3	Voltage Regulator VREGEN . . . . .	72
Table 5-1	Interrupt Vector Locations . . . . .	75
Table A-1	Absolute Maximum Ratings . . . . .	91
Table A-2	ESD and Latch-up Test Conditions . . . . .	92
Table A-3	ESD and Latch-Up Protection Characteristics . . . . .	92
Table A-4	Operating Conditions . . . . .	93
Table A-5	Thermal Package Characteristics . . . . .	95
Table A-6	5V I/O Characteristics . . . . .	96
Table A-7	Supply Current Characteristics . . . . .	98
Table A-8	ATD Operating Characteristics . . . . .	99
Table A-9	ATD Electrical Characteristics . . . . .	100
Table A-10	ATD Conversion Performance . . . . .	101
Table A-11	NVM Timing Characteristics . . . . .	104
Table A-12	NVM Reliability Characteristics . . . . .	106
Table A-13	Voltage Regulator Recommended Load Capacitances . . . . .	109
Table A-14	Startup Characteristics. . . . .	111
Table A-15	Oscillator Characteristics . . . . .	112
Table A-16	PLL Characteristics . . . . .	116
Table A-17	MSCAN Wake-up Pulse Characteristics. . . . .	117
Table A-18	Measurement Conditions. . . . .	119
Table A-19	SPI Master Mode Timing Characteristics. . . . .	120
Table A-20	SPI Slave Mode Timing Characteristics. . . . .	122

Table A-21 Expanded Bus Timing Characteristics .....125

# Derivative Differences and Document References

## Derivative Differences

**Table 0-1** shows the availability of peripheral modules on the various derivatives. For details about the compatibility within the MC9S12D-Family refer also to engineering bulletin EB386.

**Table 0-1 Derivative Differences**

Generic device	MC9S12A256	MC9S12DT256	MC9S12DJ256	MC9S12DG256
# of CANs	0	3	2	2
CAN0	—	✓	✓	✓
CAN1	—	✓	—	—
CAN4	—	✓	✓	✓
J1850/BDLC	—	—	✓	—
Package	112 LQFP/80 QFP	112 LQFP/80 QFP	112 LQFP/80 QFP	112 LQFP/80 QFP
Mask set	L91N/L01Y	L91N/L01Y	L91N/L01Y	L91N/L01Y
Temp Options	C	M, V, C	M, V, C	M, V, C
Package Code	PV/FU	PV/FU	PV/FU	PV/FU
Notes	An errata exists contact Sales Office	An errata exists contact Sales Office	An errata exists contact Sales Office	An errata exists contact Sales Office

The following figure provides an ordering number example for the MC9S12H-Family devices.

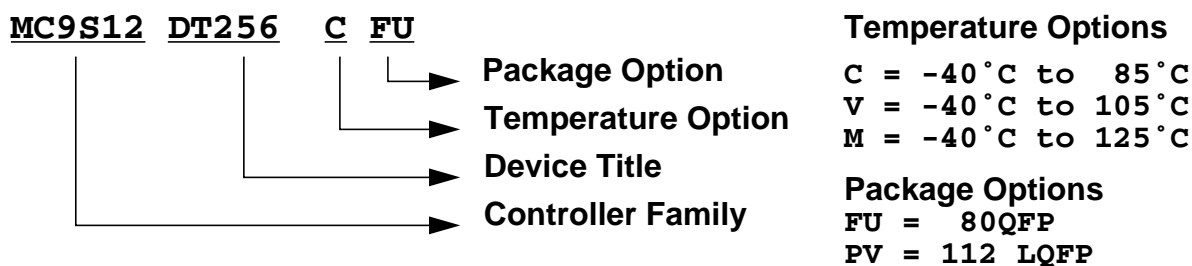

**Figure 0-1 Order Partnumber Example**

The following items should be considered when using a derivative (**Table 0-1**):

- **Registers**
  - Do not write or read CAN0 registers (after reset: address range \$0140 - \$017F), if using a derivative without CAN0.
  - Do not write or read CAN1 registers (after reset: address range \$0180 - \$01BF), if using a derivative without CAN1.
  - Do not write or read CAN4 registers (after reset: address range \$0280 - \$02BF), if using a derivative without CAN4.
  - Do not write or read BDLC registers (after reset: address range \$00E8 - \$00EF), if using a derivative without BDLC.
- **Interrupts**
  - Fill the four CAN0 interrupt vectors (\$FFB0 - \$FFB7) according to your coding policies for unused interrupts, if using a derivative without CAN0.
  - Fill the four CAN1 interrupt vectors (\$FFA8 - \$FFAF) according to your coding policies for unused interrupts, if using a derivative without CAN1.
  - Fill the four CAN4 interrupt vectors (\$FF90 - \$FF97) according to your coding policies for unused interrupts, if using a derivative without CAN4.
  - Fill the BDLC interrupt vector (\$FFC2, \$FFC3) according to your coding policies for unused interrupts, if using a derivative without BDLC.
- **Ports**
  - The CAN0 pin functionality (TXCAN0, RXCAN0) is not available on port PJ7, PJ6, PM5, PM4, PM3, PM2, PM1 and PM0, if using a derivative without CAN0.
  - The CAN1 pin functionality (TXCAN1, RXCAN1) is not available on port PM3 and PM2, if using a derivative without CAN1.
  - The CAN4 pin functionality (TXCAN4, RXCAN4) is not available on port PJ7, PJ6, PM5, PM7, PM6, PM5 and PM4, if using a derivative without CAN0.
  - The BDLC pin functionality (TXB, RXB) is not available on port PM1 and PM0, if using a derivative without BDLC.
  - Do not write MODRR1 and MODRR0 bits of Module Routing Register (PIM\_9DP256 Block Guide), if using a derivative without CAN0.
  - Do not write MODRR3 and MODRR2 bits of Module Routing Register (PIM\_9DP256 Block Guide), if using a derivative without CAN4.

## Document References



The Device Guide provides information about the MC9S12DT256 device made up of standard HCS12 blocks and the HCS12 processor core.

This document is part of the customer documentation. A complete set of device manuals also includes the HCS12 Core User Guide and all the individual Block Guides of the implemented modules. In an effort to reduce redundancy all module specific information is located only in the respective Block Guide. If applicable, special implementation details of the module are given in the block description sections of this document.

See **Table 0-2** for names and versions of the referenced documents throughout the Device User Guide.

**Table 0-2 Document References**

User Guide	Version	Document Order Number
CPU12 Reference Manual	V04	CPU12RM/AD
HCS12 Multiplexed External Bus Interface (MEBI) Block Guide	V03	S12MEBIV3/D
HCS12 Module Mapping Control (MMC) Block Guide	V04	S12MMCV4/D
HCS12 Interrupt (INT) Block Guide	V01	S12INTV1/D
HCS12 Background Debug (BDM) Block Guide	V04	S12BDMV4/D
HCS12 Breakpoint (BKP) Block Guide	V01	S12BKPV1/D
Clock and Reset Generator (CRG) Block User Guide	V04	S12CRGV4/D
Enhanced Capture Timer (ECT_16B8C) Block User Guide	V01	S12ECT16B8CV1/D
Analog to Digital Converter 10 Bit 8 Channels (ATD_10B8C) Block User Guide	V02	S12ATD10B8CV2/D
Inter IC Bus (IIC) Block User Guide	V02	S12IICV2/D
Asynchronous Serial Interface (SCI) Block User Guide	V02	S12SCIV2/D
Serial Peripheral Interface (SPI) Block User Guide	V03	S12SPIV3/D
Pulse Width Modulator 8 Bit 8 Channel (PWM_8B8C) Block User Guide	V01	S12PWM8B8CV1/D
256 K Byte Flash (FTS256K) Block User Guide	V03	S12FTS256KV3/D
4K Byte EEPROM (EETS4K) Block User Guide	V02	S12EETS4KV2/D
Byte Level Data Link Controller -J1850 (BDLC) Block User Guide	V01	S12BDLCV1/D
Motorola Scalable CAN (MSCAN) Block User Guide	V02	S12MSCANV2/D
Voltage Regulator (VREG) Block User Guide	V01	S12VREGV1/D
Port Integration Module (PIM_9DP256) Block User Guide	V03	S12PIM9DP256V3/D
Oscillator (OSC) Block Guide	V02	S12OSCV2/D

**Table 0-3** shows the Specification Change Summary for Maskset L91N.

**Table 0-3 Specification Change Summary for Maskset L91N**

Block	Spec Change
MCU_9DT256	removed CAN2 and CAN3
HCS12 V1.5	The Background Debug Module includes an Acknowledge Protocol (two additional hardware commands ACK_ENABLE/ACK_DISABLE)
HCS12 V1.5	The state of PK7/ROMCTL is latched into ROMON Bit during RESET into Emulation Mode or Normal Expanded Mode
CRG	Maskset includes an additional Pierce Oscillator

**Table 0-3 Specification Change Summary for Maskset L91N**

<b>Block</b>	<b>Spec Change</b>
EETS4K/FTS256K	Reliability Specification for Non Volatile Memories
PIM_9DP256	CAN0 can be routed to PORTJ

# Section 1 IntroductionMC9S12DT256

## 1.1 Overview

The MC9S12DT256 microcontroller unit (MCU) is a 16-bit device composed of standard on-chip peripherals including a 16-bit central processing unit (HCS12 CPU), 256K bytes of Flash EEPROM, 12K bytes of RAM, 4K bytes of EEPROM, two asynchronous serial communications interfaces (SCI), three serial peripheral interfaces (SPI), an 8-channel IC/OC enhanced capture timer, two 8-channel, 10-bit analog-to-digital converters (ADC), an 8-channel pulse-width modulator (PWM), a digital Byte Data Link Controller (BDLC), 29 discrete digital I/O channels (Port A, Port B, Port K and Port E), 20 discrete digital I/O lines with interrupt and wakeup capability, three CAN 2.0 A, B software compatible modules (MSCAN12), and an Inter-IC Bus. The MC9S12DT256 has full 16-bit data paths throughout. However, the external bus can operate in an 8-bit narrow mode so single 8-bit wide memory can be interfaced for lower cost systems. The inclusion of a PLL circuit allows power consumption and performance to be adjusted to suit operational requirements.

## 1.2 Features

- HCS12 Core
  - 16-bit HCS12 CPU
    - i. Upward compatible with M68HC11 instruction set
    - ii. Interrupt stacking and programmer's model identical to M68HC11
    - iii. Instruction queue
    - iv. Enhanced indexed addressing
  - MEBI (Multiplexed External Bus Interface)
  - MMC (Module Mapping Control)
  - INT (Interrupt control)
  - BKP (Breakpoints)
  - BDM (Background Debug Mode)
- CRG
  - Low current Colpitts or Pierce oscillator
  - PLL
  - COP watchdog
  - Real time interrupt
  - Clock Monitor
- 8-bit and 4-bit ports with interrupt functionality
  - Digital filtering

- Programmable rising or falling edge trigger
- Memory
  - 256K Flash EEPROM
  - 4K byte EEPROM
  - 12K byte RAM
- Two 8-channel Analog-to-Digital Converters
  - 10-bit resolution
  - External conversion trigger capability
- Three 1M bit per second, CAN 2.0 A, B software compatible modules
  - Five receive and three transmit buffers
  - Flexible identifier filter programmable as 2 x 32 bit, 4 x 16 bit or 8 x 8 bit
  - Four separate interrupt channels for Rx, Tx, error and wake-up
  - Low-pass filter wake-up function
  - Loop-back for self test operation
- Enhanced Capture Timer
  - 16-bit main counter with 7-bit prescaler
  - 8 programmable input capture or output compare channels
  - Four 8-bit or two 16-bit pulse accumulators
- 8 PWM channels
  - Programmable period and duty cycle
  - 8-bit 8-channel or 16-bit 4-channel
  - Separate control for each pulse width and duty cycle
  - Center-aligned or left-aligned outputs
  - Programmable clock select logic with a wide range of frequencies
  - Fast emergency shutdown input
  - Usable as interrupt inputs
- Serial interfaces
  - Two asynchronous Serial Communications Interfaces (SCI)
  - Three Synchronous Serial Peripheral Interface (SPI)
- Byte Data Link Controller (BDLC)
  - SAE J1850 Class B Data Communications Network Interface Compatible and ISO Compatible for Low-Speed (<125 Kbps) Serial Data Communications in Automotive Applications
- Inter-IC Bus (IIC)

- Compatible with I2C Bus standard
- Multi-master operation
- Software programmable for one of 256 different serial clock frequencies
- 112-Pin LQFP package
  - I/O lines with 5V input and drive capability
  - 5V A/D converter inputs
  - Operation at 50MHz equivalent to 25MHz Bus Speed
  - Development support
  - Single-wire background debug™ mode (BDM)
  - On-chip hardware breakpoints

## 1.3 Modes of Operation

### User modes

- Normal and Emulation Operating Modes
  - Normal Single-Chip Mode
  - Normal Expanded Wide Mode
  - Normal Expanded Narrow Mode
  - Emulation Expanded Wide Mode
  - Emulation Expanded Narrow Mode
- Special Operating Modes
  - Special Single-Chip Mode with active Background Debug Mode
  - Special Test Mode (**Motorola use only**)
  - Special Peripheral Mode (**Motorola use only**)

### Low power modes

- Stop Mode
- Pseudo Stop Mode
- Wait Mode

## 1.4 Block Diagram

**Figure 1-1** shows a block diagram of the MC9S12DT256 device.

Figure 1-1 MC9S12DT256 Block Diagram

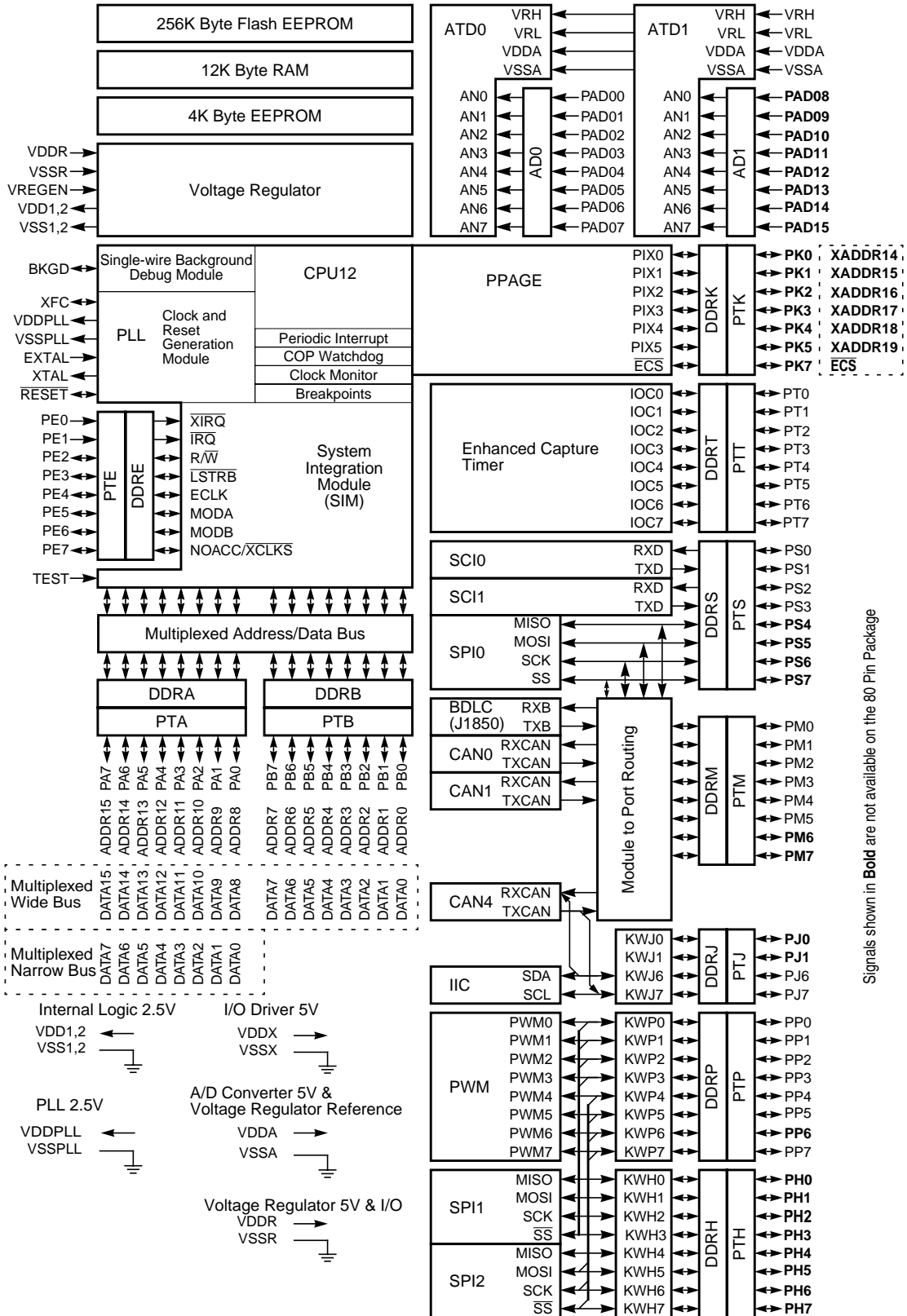

## 1.5 Device Memory Map

**Table 1-1** and **Figure 1-2** show the device memory map of the MC9S12DT256 after reset. Note that after reset the bottom 1k of the EEPROM (\$0000 - \$03FF) are hidden by the register space.

**Table 1-1 Device Memory Map**

Address	Module	Size (Bytes)
\$0000 - \$0017	CORE (Ports A, B, E, Modes, Inits, Test)	24
\$0018 - \$0019	Reserved	2
\$001A - \$001B	Device ID register (PARTID)	2
\$001C - \$001F	CORE (MEMSIZ, IRQ, HPRI0)	4
\$0020 - \$0027	Reserved	8
\$0028 - \$002F	CORE (Background Debug Mode)	8
\$0030 - \$0033	CORE (PPAGE, Port K)	4
\$0034 - \$003F	Clock and Reset Generator (PLL, RTI, COP)	12
\$0040 - \$007F	Enhanced Capture Timer 16-bit 8 channels	64
\$0080 - \$009F	Analog to Digital Converter 10-bit 8 channels (ATD0)	32
\$00A0 - \$00C7	Pulse Width Modulator 8-bit 8 channels (PWM)	40
\$00C8 - \$00CF	Serial Communications Interface (SCI0)	8
\$00D0 - \$00D7	Serial Communications Interface (SCI1)	8
\$00D8 - \$00DF	Serial Peripheral Interface (SPI0)	8
\$00E0 - \$00E7	Inter IC Bus	8
\$00E8 - \$00EF	Byte Data Link Controller (BDLC)	8
\$00F0 - \$00F7	Serial Peripheral Interface (SPI1)	8
\$00F8 - \$00FF	Serial Peripheral Interface (SPI2)	8
\$0100 - \$010F	Flash Control Register	16
\$0110 - \$011B	EEPROM Control Register	12
\$011C - \$011F	Reserved	4
\$0120 - \$013F	Analog to Digital Converter 10-bit 8 channels (ATD1)	32
\$0140 - \$017F	Motorola Scalable Can (CAN0)	64
\$0180 - \$01BF	Motorola Scalable Can (CAN1)	64
\$01C0 - \$01FF	Reserved	64
\$0200 - \$023F	Reserved	64
\$0240 - \$027F	Port Integration Module (PIM)	64
\$0280 - \$02BF	Motorola Scalable Can (CAN4)	64
\$02C0 - \$03FF	Reserved	320
\$0000 - \$0FFF	EEPROM array	4096



**Table 1-1 Device Memory Map**

<b>Address</b>	<b>Module</b>	<b>Size (Bytes)</b>
\$1000 - \$3FFF	RAM array	12288
\$4000 - \$7FFF	Fixed Flash EEPROM array incl. 0.5K, 1K, 2K or 4K Protected Sector at start	16384
\$8000 - \$BFFF	Flash EEPROM Page Window	16384
\$C000 - \$FFFF	Fixed Flash EEPROM array incl. 0.5K, 1K, 2K or 4K Protected Sector at end and 256 bytes of Vector Space at \$FF80 - \$FFFF	16384

Figure 1-2 MC9S12DT256 Memory Map

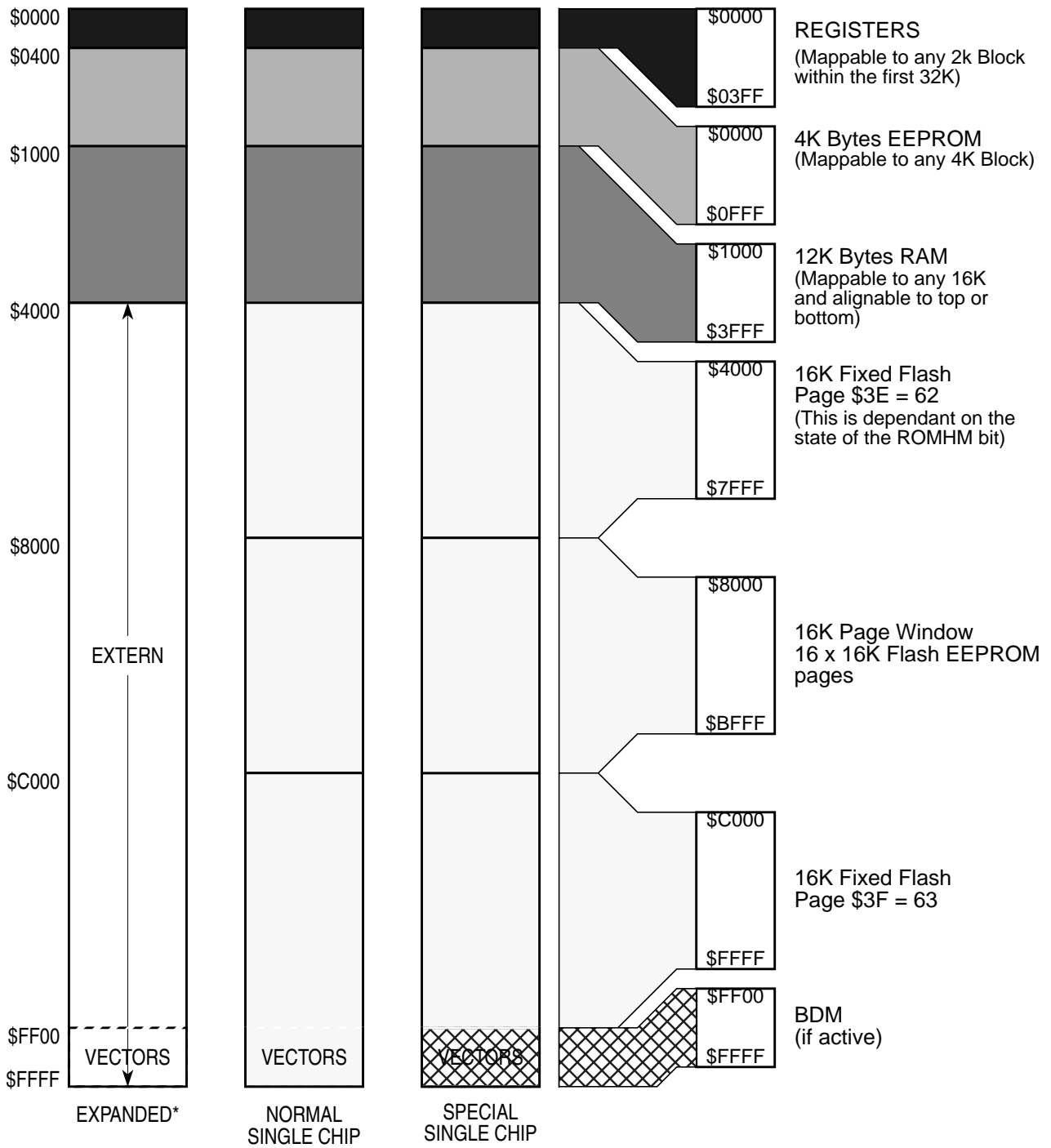

\* Assuming that a '0' was driven onto port K bit 7 during MCU is reset into normal expanded wide or narrow mode.

## 1.6 Detailed Register Map

The following tables show the detailed register map of the MC9S12DT256.

### \$0000 - \$000F

### MEBI map 1 of 3 (Core User Guide)

Address	Name		Bit 7	Bit 6	Bit 5	Bit 4	Bit 3	Bit 2	Bit 1	Bit 0
\$0000	PORTA	Read: Write:	Bit 7	6	5	4	3	2	1	Bit 0
\$0001	PORTB	Read: Write:	Bit 7	6	5	4	3	2	1	Bit 0
\$0002	DDRA	Read: Write:	Bit 7	6	5	4	3	2	1	Bit 0
\$0003	DDRB	Read: Write:	Bit 7	6	5	4	3	2	1	Bit 0
\$0004	Reserved	Read: Write:	0	0	0	0	0	0	0	0
\$0005	Reserved	Read: Write:	0	0	0	0	0	0	0	0
\$0006	Reserved	Read: Write:	0	0	0	0	0	0	0	0
\$0007	Reserved	Read: Write:	0	0	0	0	0	0	0	0
\$0008	PORTE	Read: Write:	Bit 7	6	5	4	3	2	Bit 1	Bit 0
\$0009	DDRE	Read: Write:	Bit 7	6	5	4	3	Bit 2	0	0
\$000A	PEAR	Read: Write:	NOACCE	0	PIPOE	NECLK	LSTRE	RDWE	0	0
\$000B	MODE	Read: Write:	MODC	MODB	MODA	0	IVIS	0	EMK	EME
\$000C	PUCR	Read: Write:	PUPKE	0	0	PUPEE	0	0	PUPBE	PUPAE
\$000D	RDRIV	Read: Write:	RDPK	0	0	RDPE	0	0	RDPB	RDPA
\$000E	EBICTL	Read: Write:	0	0	0	0	0	0	0	ESTR
\$000F	Reserved	Read: Write:	0	0	0	0	0	0	0	0

### \$0010 - \$0014

### MMC map 1 of 4 (Core User Guide)

Address	Name		Bit 7	Bit 6	Bit 5	Bit 4	Bit 3	Bit 2	Bit 1	Bit 0
\$0010	INITRM	Read: Write:	RAM15	RAM14	RAM13	RAM12	RAM11	0	0	RAMHAL
\$0011	INITRG	Read: Write:	0	REG14	REG13	REG12	REG11	0	0	0

**\$0010 - \$0014**

**MMC map 1 of 4 (Core User Guide)**

Address	Name		Bit 7	Bit 6	Bit 5	Bit 4	Bit 3	Bit 2	Bit 1	Bit 0
\$0012	INITEE	Read:	EE15	EE14	EE13	EE12	EE11	0	0	EEON
		Write:								
\$0013	MISC	Read:	0	0	0	0	EXSTR1	EXSTR0	ROMHM	ROMON
		Write:								
\$0014	Reserved	Read:	0	0	0	0	0	0	0	0
		Write:								

**\$0015 - \$0016**

**INT map 1 of 2 (Core User Guide)**

Address	Name		Bit 7	Bit 6	Bit 5	Bit 4	Bit 3	Bit 2	Bit 1	Bit 0
\$0015	ITCR	Read:	0	0	0	WRINT	ADR3	ADR2	ADR1	ADR0
		Write:								
\$0016	ITEST	Read:	INTE	INTC	INTA	INT8	INT6	INT4	INT2	INT0
		Write:								

**\$0017 - \$0017**

**MMC map 2 of 4 (Core User Guide)**

Address	Name		Bit 7	Bit 6	Bit 5	Bit 4	Bit 3	Bit 2	Bit 1	Bit 0
\$0017	Reserved	Read:	0	0	0	0	0	0	0	0
		Write:								

**\$0018 - \$001B**

**Miscellaneous Peripherals (Device User Guide, Table 1-3)**

Address	Name		Bit 7	Bit 6	Bit 5	Bit 4	Bit 3	Bit 2	Bit 1	Bit 0
\$0018	Reserved	Read:	0	0	0	0	0	0	0	0
		Write:								
\$0019	Reserved	Read:	0	0	0	0	0	0	0	0
		Write:								
\$001A	PARTIDH	Read:	ID15	ID14	ID13	ID12	ID11	ID10	ID9	ID8
		Write:								
\$001B	PARTIDL	Read:	ID7	ID6	ID5	ID4	ID3	ID2	ID1	ID0
		Write:								

**\$001C - \$001D**

**MMC map 3 of 4 (Core and Device User Guide, Table 1-4)**

Address	Name		Bit 7	Bit 6	Bit 5	Bit 4	Bit 3	Bit 2	Bit 1	Bit 0
\$001C	MEMSIZ0	Read:	reg_sw0	0	eep_sw1	eep_sw0	0	ram_sw2	ram_sw1	ram_sw0
		Write:								
\$001D	MEMSIZ1	Read:	rom_sw1	rom_sw0	0	0	0	0	pag_sw1	pag_sw0
		Write:								

**\$001E - \$001E****MEBI map 2 of 3 (Core User Guide)**

Address	Name	Bit 7	Bit 6	Bit 5	Bit 4	Bit 3	Bit 2	Bit 1	Bit 0
\$001E	INTCR	Read:	IRQE	IRQEN	0	0	0	0	0
		Write:							

**\$001F - \$001F****INT map 2 of 2 (Core User Guide)**

Address	Name	Bit 7	Bit 6	Bit 5	Bit 4	Bit 3	Bit 2	Bit 1	Bit 0
\$001F	HPRIO	Read:	PSEL7	PSEL6	PSEL5	PSEL4	PSEL3	PSEL2	PSEL1
		Write:							

**\$0020 - \$0027****Reserved**

Address	Name	Bit 7	Bit 6	Bit 5	Bit 4	Bit 3	Bit 2	Bit 1	Bit 0
\$0020	Reserved	Read:	0	0	0	0	0	0	0
		Write:							
\$0021	Reserved	Read:	0	0	0	0	0	0	0
		Write:							
\$0022	Reserved	Read:	0	0	0	0	0	0	0
		Write:							
\$0023	Reserved	Read:	0	0	0	0	0	0	0
		Write:							
\$0024	Reserved	Read:	0	0	0	0	0	0	0
		Write:							
\$0025	Reserved	Read:	0	0	0	0	0	0	0
		Write:							
\$0026	Reserved	Read:	0	0	0	0	0	0	0
		Write:							
\$0027	Reserved	Read:	0	0	0	0	0	0	0
		Write:							

**\$0028 - \$002F****BKP (Core User Guide)**

Address	Name	Bit 7	Bit 6	Bit 5	Bit 4	Bit 3	Bit 2	Bit 1	Bit 0
\$0028	BKPCT0	Read:	BKEN	BKFULL	BKBDM	BKTAG	0	0	0
		Write:							
\$0029	BKPCT1	Read:	BK0MBH	BK0MBL	BK1MBH	BK1MBL	BK0RWE	BK0RW	BK1RWE
		Write:							
\$002A	BKPOX	Read:	0	0	BK0V5	BK0V4	BK0V3	BK0V2	BK0V1
		Write:							
\$002B	BKPOH	Read:	Bit 15	14	13	12	11	10	9
		Write:							
\$002C	BKPOL	Read:	Bit 7	6	5	4	3	2	1
		Write:							

**\$0028 - \$002F**

**BKP (Core User Guide)**

Address	Name		Bit 7	Bit 6	Bit 5	Bit 4	Bit 3	Bit 2	Bit 1	Bit 0
\$002D	BKP1X	Read:	0	0	BK1V5	BK1V4	BK1V3	BK1V2	BK1V1	BK1V0
		Write:								
\$002E	BKP1H	Read:	Bit 15	14	13	12	11	10	9	Bit 8
		Write:								
\$002F	BKP1L	Read:	Bit 7	6	5	4	3	2	1	Bit 0
		Write:								

**\$0030 - \$0031**

**MMC map 4 of 4 (Core User Guide)**

Address	Name		Bit 7	Bit 6	Bit 5	Bit 4	Bit 3	Bit 2	Bit 1	Bit 0
\$0030	PPAGE	Read:	0	0	PIX5	PIX4	PIX3	PIX2	PIX1	PIX0
		Write:								
\$0031	Reserved	Read:	0	0	0	0	0	0	0	0
		Write:								

**\$0032 - \$0033**

**MEBI map 3 of 3 (Core User Guide)**

Address	Name		Bit 7	Bit 6	Bit 5	Bit 4	Bit 3	Bit 2	Bit 1	Bit 0
\$0032	PORTK	Read:	Bit 7	6	5	4	3	2	1	Bit 0
		Write:								
\$0033	DDRK	Read:	Bit 7	6	5	4	3	2	1	Bit 0
		Write:								

**\$0034 - \$003F**

**CRG (Clock and Reset Generator)**

Address	Name		Bit 7	Bit 6	Bit 5	Bit 4	Bit 3	Bit 2	Bit 1	Bit 0
\$0034	SYNR	Read:	0	0	SYN5	SYN4	SYN3	SYN2	SYN1	SYN0
		Write:								
\$0035	REFDV	Read:	0	0	0	0	REFDV3	REFDV2	REFDV1	REFDV0
		Write:								
\$0036	CTFLG TEST ONLY	Read:	TOUT7	TOUT6	TOUT5	TOUT4	TOUT3	TOUT2	TOUT1	TOUT0
		Write:								
\$0037	CRGFLG	Read:	RTIF	PROF	0	LOCKIF	LOCK	TRACK	SCMIF	SCM
		Write:								
\$0038	CRGINT	Read:	RTIE	0	0	LOCKIE	0	0	SCMIE	0
		Write:								
\$0039	CLKSEL	Read:	PLLSEL	PSTP	SYSWAI	ROAWAI	PLLWAI	CWAI	RTIWAI	COPWAI
		Write:								
\$003A	PLLCTL	Read:	CME	PLLON	AUTO	ACQ	0	PRE	PCE	SCME
		Write:								
\$003B	RTICTL	Read:	0	RTR6	RTR5	RTR4	RTR3	RTR2	RTR1	RTR0
		Write:								
\$003C	COPCTL	Read:	WCOP	RSBCK	0	0	0	CR2	CR1	CR0
		Write:								

**\$0034 - \$003F****CRG (Clock and Reset Generator)**

Address	Name		Bit 7	Bit 6	Bit 5	Bit 4	Bit 3	Bit 2	Bit 1	Bit 0
\$003D	FORBYP TEST ONLY	Read:	RTIBYP	COPBYP	0	PLLBYB	0	0	FCM	0
		Write:								
\$003E	CTCTL TEST ONLY	Read:	TCTL7	TCTL6	TCTL5	TCTL4	TCTL3	TCTL2	TCTL1	TCTL0
		Write:								
\$003F	ARMCOP	Read:	0	0	0	0	0	0	0	0
		Write:	Bit 7	6	5	4	3	2	1	Bit 0

**\$0040 - \$007F****ECT (Enhanced Capture Timer 16 Bit 8 Channels)**

Address	Name		Bit 7	Bit 6	Bit 5	Bit 4	Bit 3	Bit 2	Bit 1	Bit 0
\$0040	TIOS	Read:	IOS7	IOS6	IOS5	IOS4	IOS3	IOS2	IOS1	IOS0
		Write:								
\$0041	CFORC	Read:	0	0	0	0	0	0	0	0
		Write:	FOC7	FOC6	FOC5	FOC4	FOC3	FOC2	FOC1	FOC0
\$0042	OC7M	Read:	OC7M7	OC7M6	OC7M5	OC7M4	OC7M3	OC7M2	OC7M1	OC7M0
		Write:								
\$0043	OC7D	Read:	OC7D7	OC7D6	OC7D5	OC7D4	OC7D3	OC7D2	OC7D1	OC7D0
		Write:								
\$0044	TCNT (hi)	Read:	Bit 15	14	13	12	11	10	9	Bit 8
		Write:								
\$0045	TCNT (lo)	Read:	Bit 7	6	5	4	3	2	1	Bit 0
		Write:								
\$0046	TSCR1	Read:	TEN	TSWAI	TSFRZ	TFFCA	0	0	0	0
		Write:								
\$0047	TTOV	Read:	TOV7	TOV6	TOV5	TOV4	TOV3	TOV2	TOV1	TOV0
		Write:								
\$0048	TCTL1	Read:	OM7	OL7	OM6	OL6	OM5	OL5	OM4	OL4
		Write:								
\$0049	TCTL2	Read:	OM3	OL3	OM2	OL2	OM1	OL1	OM0	OL0
		Write:								
\$004A	TCTL3	Read:	EDG7B	EDG7A	EDG6B	EDG6A	EDG5B	EDG5A	EDG4B	EDG4A
		Write:								
\$004B	TCTL4	Read:	EDG3B	EDG3A	EDG2B	EDG2A	EDG1B	EDG1A	EDG0B	EDG0A
		Write:								
\$004C	TIE	Read:	C7I	C6I	C5I	C4I	C3I	C2I	C1I	C0I
		Write:								
\$004D	TSCR2	Read:	TOI	0	0	0	TCRE	PR2	PR1	PR0
		Write:								
\$004E	TFLG1	Read:	C7F	C6F	C5F	C4F	C3F	C2F	C1F	C0F
		Write:								
\$004F	TFLG2	Read:	TOF	0	0	0	0	0	0	0
		Write:								
\$0050	TC0 (hi)	Read:	Bit 15	14	13	12	11	10	9	Bit 8
		Write:								
\$0051	TC0 (lo)	Read:	Bit 7	6	5	4	3	2	1	Bit 0
		Write:								
\$0052	TC1 (hi)	Read:	Bit 15	14	13	12	11	10	9	Bit 8
		Write:								

**\$0040 - \$007F**

**ECT (Enhanced Capture Timer 16 Bit 8 Channels)**

Address	Name		Bit 7	Bit 6	Bit 5	Bit 4	Bit 3	Bit 2	Bit 1	Bit 0
\$0053	TC1 (lo)	Read: Write:	Bit 7	6	5	4	3	2	1	Bit 0
\$0054	TC2 (hi)	Read: Write:	Bit 15	14	13	12	11	10	9	Bit 8
\$0055	TC2 (lo)	Read: Write:	Bit 7	6	5	4	3	2	1	Bit 0
\$0056	TC3 (hi)	Read: Write:	Bit 15	14	13	12	11	10	9	Bit 8
\$0057	TC3 (lo)	Read: Write:	Bit 7	6	5	4	3	2	1	Bit 0
\$0058	TC4 (hi)	Read: Write:	Bit 15	14	13	12	11	10	9	Bit 8
\$0059	TC4 (lo)	Read: Write:	Bit 7	6	5	4	3	2	1	Bit 0
\$005A	TC5 (hi)	Read: Write:	Bit 15	14	13	12	11	10	9	Bit 8
\$005B	TC5 (lo)	Read: Write:	Bit 7	6	5	4	3	2	1	Bit 0
\$005C	TC6 (hi)	Read: Write:	Bit 15	14	13	12	11	10	9	Bit 8
\$005D	TC6 (lo)	Read: Write:	Bit 7	6	5	4	3	2	1	Bit 0
\$005E	TC7 (hi)	Read: Write:	Bit 15	14	13	12	11	10	9	Bit 8
\$005F	TC7 (lo)	Read: Write:	Bit 7	6	5	4	3	2	1	Bit 0
\$0060	PACTL	Read: Write:	0	PAEN	PAMOD	PEDGE	CLK1	CLK0	PAOVI	PAI
\$0061	PAFLG	Read: Write:	0	0	0	0	0	0	PAOVF	PAIF
\$0062	PACN3 (hi)	Read: Write:	Bit 7	6	5	4	3	2	1	Bit 0
\$0063	PACN2 (lo)	Read: Write:	Bit 7	6	5	4	3	2	1	Bit 0
\$0064	PACN1 (hi)	Read: Write:	Bit 7	6	5	4	3	2	1	Bit 0
\$0065	PACN0 (lo)	Read: Write:	Bit 7	6	5	4	3	2	1	Bit 0
\$0066	MCCTL	Read: Write:	MCZI	MODMC	RDMCL	0 ICLAT	0 FLMC	MCEN	MCPR1	MCPR0
\$0067	MCFLG	Read: Write:	MCZF	0	0	0	POLF3	POLF2	POLF1	POLF0
\$0068	ICPAR	Read: Write:	0	0	0	0	PA3EN	PA2EN	PA1EN	PA0EN
\$0069	DLYCT	Read: Write:	0	0	0	0	0	0	DLY1	DLY0
\$006A	ICOVW	Read: Write:	NOVW7	NOVW6	NOVW5	NOVW4	NOVW3	NOVW2	NOVW1	NOVW0
\$006B	ICSYS	Read: Write:	SH37	SH26	SH15	SH04	TFMOD	PACMX	BUFEN	LATQ



**\$0040 - \$007F****ECT (Enhanced Capture Timer 16 Bit 8 Channels)**

Address	Name		Bit 7	Bit 6	Bit 5	Bit 4	Bit 3	Bit 2	Bit 1	Bit 0
\$006C	Reserved	Read:								
		Write:								
\$006D	TIMTST	Read:	0	0	0	0	0	0	TCBYP	0
	Test Only	Write:								
\$006E	Reserved	Read:								
		Write:								
\$006F	Reserved	Read:								
		Write:								
\$0070	PBCTL	Read:	0	PBEN	0	0	0	0	PBOVI	0
		Write:								
\$0071	PBFLG	Read:	0	0	0	0	0	0	PBOVF	0
		Write:								
\$0072	PA3H	Read:	Bit 7	6	5	4	3	2	1	Bit 0
		Write:								
\$0073	PA2H	Read:	Bit 7	6	5	4	3	2	1	Bit 0
		Write:								
\$0074	PA1H	Read:	Bit 7	6	5	4	3	2	1	Bit 0
		Write:								
\$0075	PA0H	Read:	Bit 7	6	5	4	3	2	1	Bit 0
		Write:								
\$0076	MCCNT (hi)	Read:	Bit 15	14	13	12	11	10	9	Bit 8
		Write:								
\$0077	MCCNT (lo)	Read:	Bit 7	6	5	4	3	2	1	Bit 0
		Write:								
\$0078	TC0H (hi)	Read:	Bit 15	14	13	12	11	10	9	Bit 8
		Write:								
\$0079	TC0H (lo)	Read:	Bit 7	6	5	4	3	2	1	Bit 0
		Write:								
\$007A	TC1H (hi)	Read:	Bit 15	14	13	12	11	10	9	Bit 8
		Write:								
\$007B	TC1H (lo)	Read:	Bit 7	6	5	4	3	2	1	Bit 0
		Write:								
\$007C	TC2H (hi)	Read:	Bit 15	14	13	12	11	10	9	Bit 8
		Write:								
\$007D	TC2H (lo)	Read:	Bit 7	6	5	4	3	2	1	Bit 0
		Write:								
\$007E	TC3H (hi)	Read:	Bit 15	14	13	12	11	10	9	Bit 8
		Write:								
\$007F	TC3H (lo)	Read:	Bit 7	6	5	4	3	2	1	Bit 0
		Write:								

**\$0080 - \$009F****ATD0 (Analog to Digital Converter 10 Bit 8 Channel)**

Address	Name		Bit 7	Bit 6	Bit 5	Bit 4	Bit 3	Bit 2	Bit 1	Bit 0
\$0080	ATD0CTL0	Read:	0	0	0	0	0	0	0	0
		Write:								
\$0081	ATD0CTL1	Read:	0	0	0	0	0	0	0	0
		Write:								

**\$0080 - \$009F**

**ATD0 (Analog to Digital Converter 10 Bit 8 Channel)**

Address	Name		Bit 7	Bit 6	Bit 5	Bit 4	Bit 3	Bit 2	Bit 1	Bit 0
\$0082	ATD0CTL2	Read:	ADPU	AFFC	AWAI	ETRIGLE	ETRIGP	ETRIG	ASCIE	ASCIF
		Write:								
\$0083	ATD0CTL3	Read:	0	S8C	S4C	S2C	S1C	FIFO	FRZ1	FRZ0
		Write:								
\$0084	ATD0CTL4	Read:	SRES8	SMP1	SMP0	PRS4	PRS3	PRS2	PRS1	PRS0
		Write:								
\$0085	ATD0CTL5	Read:	DJM	DSGN	SCAN	MULT	0	CC	CB	CA
		Write:								
\$0086	ATD0STAT0	Read:	SCF	0	ETORF	FIFOR	0	CC2	CC1	CC0
		Write:								
\$0087	Reserved	Read:	0	0	0	0	0	0	0	0
		Write:								
\$0088	ATD0TEST0	Read:	0	0	0	0	0	0	0	0
		Write:								
\$0089	ATD0TEST1	Read:	0	0	0	0	0	0	0	SC
		Write:								
\$008A	Reserved	Read:	0	0	0	0	0	0	0	0
		Write:								
\$008B	ATD0STAT1	Read:	CCF7	CCF6	CCF5	CCF4	CCF3	CCF2	CCF1	CCF0
		Write:								
\$008C	Reserved	Read:	0	0	0	0	0	0	0	0
		Write:								
\$008D	ATD0DIEN	Read:	Bit 7	6	5	4	3	2	1	Bit 0
		Write:								
\$008E	Reserved	Read:	0	0	0	0	0	0	0	0
		Write:								
\$008F	PORTAD0	Read:	Bit7	6	5	4	3	2	1	BIT 0
		Write:								
\$0090	ATD0DR0H	Read:	Bit15	14	13	12	11	10	9	Bit8
		Write:								
\$0091	ATD0DR0L	Read:	Bit7	Bit6	0	0	0	0	0	0
		Write:								
\$0092	ATD0DR1H	Read:	Bit15	14	13	12	11	10	9	Bit8
		Write:								
\$0093	ATD0DR1L	Read:	Bit7	Bit6	0	0	0	0	0	0
		Write:								
\$0094	ATD0DR2H	Read:	Bit15	14	13	12	11	10	9	Bit8
		Write:								
\$0095	ATD0DR2L	Read:	Bit7	Bit6	0	0	0	0	0	0
		Write:								
\$0096	ATD0DR3H	Read:	Bit15	14	13	12	11	10	9	Bit8
		Write:								
\$0097	ATD0DR3L	Read:	Bit7	Bit6	0	0	0	0	0	0
		Write:								
\$0098	ATD0DR4H	Read:	Bit15	14	13	12	11	10	9	Bit8
		Write:								
\$0099	ATD0DR4L	Read:	Bit7	Bit6	0	0	0	0	0	0
		Write:								
\$009A	ATD0DR5H	Read:	Bit15	14	13	12	11	10	9	Bit8
		Write:								

**\$0080 - \$009F****ATD0 (Analog to Digital Converter 10 Bit 8 Channel)**

Address	Name		Bit 7	Bit 6	Bit 5	Bit 4	Bit 3	Bit 2	Bit 1	Bit 0
\$009B	ATD0DR5L	Read:	Bit7	Bit6	0	0	0	0	0	0
		Write:								
\$009C	ATD0DR6H	Read:	Bit15	14	13	12	11	10	9	Bit8
		Write:								
\$009D	ATD0DR6L	Read:	Bit7	Bit6	0	0	0	0	0	0
		Write:								
\$009E	ATD0DR7H	Read:	Bit15	14	13	12	11	10	9	Bit8
		Write:								
\$009F	ATD0DR7L	Read:	Bit7	Bit6	0	0	0	0	0	0
		Write:								

**\$00A0 - \$00C7****PWM (Pulse Width Modulator 8 Bit 8 Channel)**

Address	Name		Bit 7	Bit 6	Bit 5	Bit 4	Bit 3	Bit 2	Bit 1	Bit 0
\$00A0	PWME	Read:	PWME7	PWME6	PWME5	PWME4	PWME3	PWME2	PWME1	PWME0
		Write:								
\$00A1	PWMPOL	Read:	PPOL7	PPOL6	PPOL5	PPOL4	PPOL3	PPOL2	PPOL1	PPOL0
		Write:								
\$00A2	PWMCLK	Read:	PCLK7	PCLK6	PCLK5	PCLK4	PCLK3	PCLK2	PCLK1	PCLK0
		Write:								
\$00A3	PWMPRCLK	Read:	0	PCKB2	PCKB1	PCKB0	0	PCKA2	PCKA1	PCKA0
		Write:								
\$00A4	PWMCAE	Read:	CAE7	CAE6	CAE5	CAE4	CAE3	CAE2	CAE1	CAE0
		Write:								
\$00A5	PWMCTL	Read:	CON67	CON45	CON23	CON01	PSWAI	PFRZ	0	0
		Write:								
\$00A6	PWMTST Test Only	Read:	0	0	0	0	0	0	0	0
		Write:								
\$00A7	PWMPRSC	Read:	0	0	0	0	0	0	0	0
		Write:								
\$00A8	PWMSCLA	Read:	Bit 7	6	5	4	3	2	1	Bit 0
		Write:								
\$00A9	PWMSCLB	Read:	Bit 7	6	5	4	3	2	1	Bit 0
		Write:								
\$00AA	PWMSCNTA	Read:	0	0	0	0	0	0	0	0
		Write:								
\$00AB	PWMSCNTB	Read:	0	0	0	0	0	0	0	0
		Write:								
\$00AC	PWMCNT0	Read:	Bit 7	6	5	4	3	2	1	Bit 0
		Write:	0	0	0	0	0	0	0	0
\$00AD	PWMCNT1	Read:	Bit 7	6	5	4	3	2	1	Bit 0
		Write:	0	0	0	0	0	0	0	0
\$00AE	PWMCNT2	Read:	Bit 7	6	5	4	3	2	1	Bit 0
		Write:	0	0	0	0	0	0	0	0
\$00AF	PWMCNT3	Read:	Bit 7	6	5	4	3	2	1	Bit 0
		Write:	0	0	0	0	0	0	0	0
\$00B0	PWMCNT4	Read:	Bit 7	6	5	4	3	2	1	Bit 0
		Write:	0	0	0	0	0	0	0	0

**\$00A0 - \$00C7**

**PWM (Pulse Width Modulator 8 Bit 8 Channel)**

Address	Name		Bit 7	Bit 6	Bit 5	Bit 4	Bit 3	Bit 2	Bit 1	Bit 0
\$00B1	PWMCNT5	Read:	Bit 7	6	5	4	3	2	1	Bit 0
		Write:	0	0	0	0	0	0	0	0
\$00B2	PWMCNT6	Read:	Bit 7	6	5	4	3	2	1	Bit 0
		Write:	0	0	0	0	0	0	0	0
\$00B3	PWMCNT7	Read:	Bit 7	6	5	4	3	2	1	Bit 0
		Write:	0	0	0	0	0	0	0	0
\$00B4	PWMPER0	Read:	Bit 7	6	5	4	3	2	1	Bit 0
		Write:								
\$00B5	PWMPER1	Read:	Bit 7	6	5	4	3	2	1	Bit 0
		Write:								
\$00B6	PWMPER2	Read:	Bit 7	6	5	4	3	2	1	Bit 0
		Write:								
\$00B7	PWMPER3	Read:	Bit 7	6	5	4	3	2	1	Bit 0
		Write:								
\$00B8	PWMPER4	Read:	Bit 7	6	5	4	3	2	1	Bit 0
		Write:								
\$00B9	PWMPER5	Read:	Bit 7	6	5	4	3	2	1	Bit 0
		Write:								
\$00BA	PWMPER6	Read:	Bit 7	6	5	4	3	2	1	Bit 0
		Write:								
\$00BB	PWMPER7	Read:	Bit 7	6	5	4	3	2	1	Bit 0
		Write:								
\$00BC	PWMDTY0	Read:	Bit 7	6	5	4	3	2	1	Bit 0
		Write:								
\$00BD	PWMDTY1	Read:	Bit 7	6	5	4	3	2	1	Bit 0
		Write:								
\$00BE	PWMDTY2	Read:	Bit 7	6	5	4	3	2	1	Bit 0
		Write:								
\$00BF	PWMDTY3	Read:	Bit 7	6	5	4	3	2	1	Bit 0
		Write:								
\$00C0	PWMDTY4	Read:	Bit 7	6	5	4	3	2	1	Bit 0
		Write:								
\$00C1	PWMDTY5	Read:	Bit 7	6	5	4	3	2	1	Bit 0
		Write:								
\$00C2	PWMDTY6	Read:	Bit 7	6	5	4	3	2	1	Bit 0
		Write:								
\$00C3	PWMDTY7	Read:	Bit 7	6	5	4	3	2	1	Bit 0
		Write:								
\$00C4	PWMSDN	Read:	PWMIF	PWMIE	PWMRS TRT	PWMLVL	0	PWM7IN	PWM7IN L	PWM7E NA
		Write:								
\$00C5	Reserved	Read:	0	0	0	0	0	0	0	0
		Write:								
\$00C6	Reserved	Read:	0	0	0	0	0	0	0	0
		Write:								
\$00C7	Reserved	Read:	0	0	0	0	0	0	0	0
		Write:								

**\$00C8 - \$00CF****SCI0 (Asynchronous Serial Interface)**

Address	Name		Bit 7	Bit 6	Bit 5	Bit 4	Bit 3	Bit 2	Bit 1	Bit 0
\$00C8	SCI0BDH	Read:	0	0	0	SBR12	SBR11	SBR10	SBR9	SBR8
		Write:								
\$00C9	SCI0BDL	Read:	SBR7	SBR6	SBR5	SBR4	SBR3	SBR2	SBR1	SBR0
		Write:								
\$00CA	SCI0CR1	Read:	LOOPS	SCISWAI	RSRC	M	WAKE	ILT	PE	PT
		Write:								
\$00CB	SCI0CR2	Read:	TIE	TCIE	RIE	ILIE	TE	RE	RWU	SBK
		Write:								
\$00CC	SCI0SR1	Read:	TDRE	TC	RDRF	IDLE	OR	NF	FE	PF
		Write:								
\$00CD	SCI0SR2	Read:	0	0	0	0	0	BRK13	TXDIR	RAF
		Write:								
\$00CE	SCI0DRH	Read:	R8	T8	0	0	0	0	0	0
		Write:								
\$00CF	SCI0DRL	Read:	R7	R6	R5	R4	R3	R2	R1	R0
		Write:	T7	T6	T5	T4	T3	T2	T1	T0

**\$00D0 - \$00D7****SCI1 (Asynchronous Serial Interface)**

Address	Name		Bit 7	Bit 6	Bit 5	Bit 4	Bit 3	Bit 2	Bit 1	Bit 0
\$00D0	SCI1BDH	Read:	0	0	0	SBR12	SBR11	SBR10	SBR9	SBR8
		Write:								
\$00D1	SCI1BDL	Read:	SBR7	SBR6	SBR5	SBR4	SBR3	SBR2	SBR1	SBR0
		Write:								
\$00D2	SCI1CR1	Read:	LOOPS	SCISWAI	RSRC	M	WAKE	ILT	PE	PT
		Write:								
\$00D3	SCI1CR2	Read:	TIE	TCIE	RIE	ILIE	TE	RE	RWU	SBK
		Write:								
\$00D4	SCI1SR1	Read:	TDRE	TC	RDRF	IDLE	OR	NF	FE	PF
		Write:								
\$00D5	SCI1SR2	Read:	0	0	0	0	0	BRK13	TXDIR	RAF
		Write:								
\$00D6	SCI1DRH	Read:	R8	T8	0	0	0	0	0	0
		Write:								
\$00D7	SCI1DRL	Read:	R7	R6	R5	R4	R3	R2	R1	R0
		Write:	T7	T6	T5	T4	T3	T2	T1	T0

**\$00D8 - \$00DF****SPI0 (Serial Peripheral Interface)**

Address	Name		Bit 7	Bit 6	Bit 5	Bit 4	Bit 3	Bit 2	Bit 1	Bit 0
\$00D8	SPI0CR1	Read:	SPIE	SPE	SPTIE	MSTR	CPOL	CPHA	SSOE	LSBFE
		Write:								
\$00D9	SPI0CR2	Read:	0	0	0	MODFEN	BIDIROE	0	SPISWAI	SPC0
		Write:								
\$00DA	SPI0BR	Read:	0	SPPR2	SPPR1	SPPR0	0	SPR2	SPR1	SPR0
		Write:								
\$00DB	SPI0SR	Read:	SPIF	0	SPTEF	MODF	0	0	0	0
		Write:								

**\$00D8 - \$00DF**

**SPI0 (Serial Peripheral Interface)**

Address	Name		Bit 7	Bit 6	Bit 5	Bit 4	Bit 3	Bit 2	Bit 1	Bit 0
\$00DC	Reserved	Read:	0	0	0	0	0	0	0	0
		Write:								
\$00DD	SPI0DR	Read:	Bit7	6	5	4	3	2	1	Bit0
		Write:								
\$00DE	Reserved	Read:	0	0	0	0	0	0	0	0
		Write:								
\$00DF	Reserved	Read:	0	0	0	0	0	0	0	0
		Write:								

**\$00E0 - \$00E7**

**IIC (Inter IC Bus)**

Address	Name		Bit 7	Bit 6	Bit 5	Bit 4	Bit 3	Bit 2	Bit 1	Bit 0
\$00E0	IBAD	Read:	ADR7	ADR6	ADR5	ADR4	ADR3	ADR2	ADR1	0
		Write:								
\$00E1	IBFD	Read:	IBC7	IBC6	IBC5	IBC4	IBC3	IBC2	IBC1	IBC0
		Write:								
\$00E2	IBCR	Read:	IBEN	IBIE	MS/SL	TX/RX	TXAK	0	0	IBSWAI
		Write:						RSTA		
\$00E3	IBSR	Read:	TCF	IAAS	IBB	IBAL	0	SRW	IBIF	RXAK
		Write:								
\$00E4	IBDR	Read:	D7	D6	D5	D4	D3	D2	D1	D0
		Write:								
\$00E5	Reserved	Read:	0	0	0	0	0	0	0	0
		Write:								
\$00E6	Reserved	Read:	0	0	0	0	0	0	0	0
		Write:								
\$00E7	Reserved	Read:	0	0	0	0	0	0	0	0
		Write:								

**\$00E8 - \$00EF**

**BDLC (Bytelevel Data Link Controller J1850)**

Address	Name		Bit 7	Bit 6	Bit 5	Bit 4	Bit 3	Bit 2	Bit 1	Bit 0
\$00E8	DLCBCR1	Read:	IMSG	CLKS	0	0	0	0	IE	WCM
		Write:								
\$00E9	DLCBSVR	Read:	0	0	I3	I2	I1	I0	0	0
		Write:								
\$00EA	DLCBCR2	Read:	SMRST	DLOOP	RX4XE	NBFS	TEOD	TSIFR	TMIFR1	TMIFR0
		Write:								
\$00EB	DLCBDR	Read:	D7	D6	D5	D4	D3	D2	D1	D0
		Write:								
\$00EC	DLCBARD	Read:	0	RXPOL	0	0	BO3	BO2	BO1	BO0
		Write:								
\$00ED	DLCBRSR	Read:	0	0	R5	R4	R3	R2	R1	R0
		Write:								
\$00EE	DLCSCR	Read:	0	0	0	BDLCE	0	0	0	0
		Write:								
\$00EF	DLCBSTAT	Read:	0	0	0	0	0	0	0	IDLE
		Write:								

**\$00F0 - \$00F7****SPI1 (Serial Peripheral Interface)**

Address	Name		Bit 7	Bit 6	Bit 5	Bit 4	Bit 3	Bit 2	Bit 1	Bit 0
\$00F0	SPI1CR1	Read:	SPIE	SPE	SPTIE	MSTR	CPOL	CPHA	SSOE	LSBFE
		Write:								
\$00F1	SPI1CR2	Read:	0	0	0	MODFEN	BIDIROE	0	SPISWAI	SPC0
		Write:								
\$00F2	SPI1BR	Read:	0	SPPR2	SPPR1	SPPR0	0	SPR2	SPR1	SPR0
		Write:								
\$00F3	SPI1SR	Read:	SPIF	0	SPTEF	MODF	0	0	0	0
		Write:								
\$00F4	Reserved	Read:	0	0	0	0	0	0	0	0
		Write:								
\$00F5	SPI1DR	Read:	Bit7	6	5	4	3	2	1	Bit0
		Write:								
\$00F6	Reserved	Read:	0	0	0	0	0	0	0	0
		Write:								
\$00F7	Reserved	Read:	0	0	0	0	0	0	0	0
		Write:								

**\$00F8 - \$00FF****SPI2 (Serial Peripheral Interface)**

Address	Name		Bit 7	Bit 6	Bit 5	Bit 4	Bit 3	Bit 2	Bit 1	Bit 0
\$00F8	SPI2CR1	Read:	SPIE	SPE	SPTIE	MSTR	CPOL	CPHA	SSOE	LSBFE
		Write:								
\$00F9	SPI2CR2	Read:	0	0	0	MODFEN	BIDIROE	0	SPISWAI	SPC0
		Write:								
\$00FA	SPI2BR	Read:	0	SPPR2	SPPR1	SPPR0	0	SPR2	SPR1	SPR0
		Write:								
\$00FB	SPI2SR	Read:	SPIF	0	SPTEF	MODF	0	0	0	0
		Write:								
\$00FC	Reserved	Read:	0	0	0	0	0	0	0	0
		Write:								
\$00FD	SPI2DR	Read:	Bit7	6	5	4	3	2	1	Bit0
		Write:								
\$00FE	Reserved	Read:	0	0	0	0	0	0	0	0
		Write:								
\$00FF	Reserved	Read:	0	0	0	0	0	0	0	0
		Write:								

**\$0100 - \$010F****Flash Control Register (fts256k)**

Address	Name		Bit 7	Bit 6	Bit 5	Bit 4	Bit 3	Bit 2	Bit 1	Bit 0
\$0100	FCLKDIV	Read:	FDIVLD	PRDIV8	FDIV5	FDIV4	FDIV3	FDIV2	FDIV1	FDIV0
		Write:								
\$0101	FSEC	Read:	KEYEN1	KEYEN0	NV5	NV4	NV3	NV2	SEC1	SEC0
		Write:								
\$0102	FTSTMOD	Read:	0	0	0	WRALL	0	0	0	0
		Write:								
\$0103	FCNFG	Read:	CBEIE	CCIE	KEYACC	0	0	0	BKSEL1	BKSEL0
		Write:								

**\$0100 - \$010F**

**Flash Control Register (fts256k)**

Address	Name		Bit 7	Bit 6	Bit 5	Bit 4	Bit 3	Bit 2	Bit 1	Bit 0
\$0104	FPROT	Read:	FPOPEN	NV6	FPHDIS	FPHS1	FPHS0	FPLDIS	FPLS1	FPLS0
		Write:								
\$0105	FSTAT	Read:	CBEIF	CCIF	PVIOL	ACCERR	0	BLANK	0	0
		Write:								
\$0106	FCMD	Read:	0	CMDB6	CMDB5	0	0	CMDB2	0	CMDB0
		Write:								
\$0107	Reserved for Factory Test	Read:	0	0	0	0	0	0	0	0
		Write:								
\$0108	FADDRHI	Read:	0	Bit 14	13	12	11	10	9	Bit 8
		Write:								
\$0109	FADDRLO	Read:	Bit 7	6	5	4	3	2	1	Bit 0
		Write:								
\$010A	FDATAHI	Read:	Bit 15	14	13	12	11	10	9	Bit 8
		Write:								
\$010B	FDATALO	Read:	Bit 7	6	5	4	3	2	1	Bit 0
		Write:								
\$010C	Reserved	Read:	0	0	0	0	0	0	0	0
		Write:								
\$010D	Reserved	Read:	0	0	0	0	0	0	0	0
		Write:								
\$010E	Reserved	Read:	0	0	0	0	0	0	0	0
		Write:								
\$010F	Reserved	Read:	0	0	0	0	0	0	0	0
		Write:								

**\$0110 - \$011B**

**EEPROM Control Register (eets4k)**

Address	Name		Bit 7	Bit 6	Bit 5	Bit 4	Bit 3	Bit 2	Bit 1	Bit 0
\$0110	ECLKDIV	Read:	EDIVLD	PRDIV8	EDIV5	EDIV4	EDIV3	EDIV2	EDIV1	EDIV0
		Write:								
\$0111	Reserved	Read:	0	0	0	0	0	0	0	0
		Write:								
\$0112	Reserved for Factory Test	Read:	0	0	0	0	0	0	0	0
		Write:								
\$0113	ECNFG	Read:	CBEIE	CCIE	0	0	0	0	0	0
		Write:								
\$0114	EPROT	Read:	EPOPEN	NV6	NV5	NV4	EPDIS	EP2	EP1	EP0
		Write:								
\$0115	ESTAT	Read:	CBEIF	CCIF	PVIOL	ACCERR	0	BLANK	0	0
		Write:								
\$0116	ECMD	Read:	0	CMDB6	CMDB5	0	0	CMDB2	0	CMDB0
		Write:								
\$0117	Reserved for Factory Test	Read:	0	0	0	0	0	0	0	0
		Write:								
\$0118	EADDRHI	Read:	0	0	0	0	0	10	9	Bit 8
		Write:								



**\$0110 - \$011B****EEPROM Control Register (eets4k)**

Address	Name		Bit 7	Bit 6	Bit 5	Bit 4	Bit 3	Bit 2	Bit 1	Bit 0
\$0119	EADDRLO	Read:	Bit 7	6	5	4	3	2	1	Bit 0
		Write:								
\$011A	EDATAHI	Read:	Bit 15	14	13	12	11	10	9	Bit 8
		Write:								
\$011B	EDATALO	Read:	Bit 7	6	5	4	3	2	1	Bit 0
		Write:								

**\$011C - \$011F****Reserved for RAM Control Register**

Address	Name		Bit 7	Bit 6	Bit 5	Bit 4	Bit 3	Bit 2	Bit 1	Bit 0
\$011C	Reserved	Read:	0	0	0	0	0	0	0	0
		Write:								
\$011D	Reserved	Read:	0	0	0	0	0	0	0	0
		Write:								
\$011E	Reserved	Read:	0	0	0	0	0	0	0	0
		Write:								
\$011F	Reserved	Read:	0	0	0	0	0	0	0	0
		Write:								

**\$0120 - \$013F****ATD1 (Analog to Digital Converter 10 Bit 8 Channel)**

Address	Name		Bit 7	Bit 6	Bit 5	Bit 4	Bit 3	Bit 2	Bit 1	Bit 0
\$0120	ATD1CTL0	Read:	0	0	0	0	0	0	0	0
		Write:								
\$0121	ATD1CTL1	Read:	0	0	0	0	0	0	0	0
		Write:								
\$0122	ATD1CTL2	Read:	ADPU	AFFC	AWAI	ETRIGLE	ETRIGP	ETRIG	ASCIE	ASCIF
		Write:								
\$0123	ATD1CTL3	Read:	0	S8C	S4C	S2C	S1C	FIFO	FRZ1	FRZ0
		Write:								
\$0124	ATD1CTL4	Read:	SRES8	SMP1	SMP0	PRS4	PRS3	PRS2	PRS1	PRS0
		Write:								
\$0125	ATD1CTL5	Read:	DJM	DSGN	SCAN	MULT	0	CC	CB	CA
		Write:								
\$0126	ATD1STAT0	Read:	SCF	0	ETORF	FIFOR	0	CC2	CC1	CC0
		Write:								
\$0127	Reserved	Read:	0	0	0	0	0	0	0	0
		Write:								
\$0128	ATD1TEST0	Read:	0	0	0	0	0	0	0	0
		Write:								
\$0129	ATD1TEST1	Read:	0	0	0	0	0	0	0	SC
		Write:								
\$012A	Reserved	Read:	0	0	0	0	0	0	0	0
		Write:								
\$012B	ATD1STAT1	Read:	CCF7	CCF6	CCF5	CCF4	CCF3	CCF2	CCF1	CCF0
		Write:								
\$012C	Reserved	Read:	0	0	0	0	0	0	0	0
		Write:								

**\$0120 - \$013F**

**ATD1 (Analog to Digital Converter 10 Bit 8 Channel)**

Address	Name		Bit 7	Bit 6	Bit 5	Bit 4	Bit 3	Bit 2	Bit 1	Bit 0
\$012D	ATD1DIEN	Read:	Bit 7	6	5	4	3	2	1	Bit 0
		Write:								
\$012E	Reserved	Read:	0	0	0	0	0	0	0	0
		Write:								
\$012F	PORTAD1	Read:	Bit7	6	5	4	3	2	1	BIT 0
		Write:								
\$0130	ATD1DR0H	Read:	Bit15	14	13	12	11	10	9	Bit8
		Write:								
\$0131	ATD1DR0L	Read:	Bit7	Bit6	0	0	0	0	0	0
		Write:								
\$0132	ATD1DR1H	Read:	Bit15	14	13	12	11	10	9	Bit8
		Write:								
\$0133	ATD1DR1L	Read:	Bit7	Bit6	0	0	0	0	0	0
		Write:								
\$0134	ATD1DR2H	Read:	Bit15	14	13	12	11	10	9	Bit8
		Write:								
\$0135	ATD1DR2L	Read:	Bit7	Bit6	0	0	0	0	0	0
		Write:								
\$0136	ATD1DR3H	Read:	Bit15	14	13	12	11	10	9	Bit8
		Write:								
\$0137	ATD1DR3L	Read:	Bit7	Bit6	0	0	0	0	0	0
		Write:								
\$0138	ATD1DR4H	Read:	Bit15	14	13	12	11	10	9	Bit8
		Write:								
\$0139	ATD1DR4L	Read:	Bit7	Bit6	0	0	0	0	0	0
		Write:								
\$013A	ATD1DR5H	Read:	Bit15	14	13	12	11	10	9	Bit8
		Write:								
\$013B	ATD1DR5L	Read:	Bit7	Bit6	0	0	0	0	0	0
		Write:								
\$013C	ATD1DR6H	Read:	Bit15	14	13	12	11	10	9	Bit8
		Write:								
\$013D	ATD1DR6L	Read:	Bit7	Bit6	0	0	0	0	0	0
		Write:								
\$013E	ATD1DR7H	Read:	Bit15	14	13	12	11	10	9	Bit8
		Write:								
\$013F	ATD1DR7L	Read:	Bit7	Bit6	0	0	0	0	0	0
		Write:								

**\$0140 - \$017F**

**CAN0 (Motorola Scalable CAN - MSCAN)**

Address	Name		Bit 7	Bit 6	Bit 5	Bit 4	Bit 3	Bit 2	Bit 1	Bit 0
\$0140	CAN0CTL0	Read:	RXFRM	RXACT	CSWAI	SYNCH	TIME	WUPE	SLPRQ	INITRQ
		Write:								
\$0141	CAN0CTL1	Read:	CANE	CLKSRC	LOOPB	LISTEN	0	WUPM	SLPAK	INITAK
		Write:								
\$0142	CAN0BTR0	Read:	SJW1	SJW0	BRP5	BRP4	BRP3	BRP2	BRP1	BRP0
		Write:								

## \$0140 - \$017F

## CAN0 (Motorola Scalable CAN - MSCAN)

Address	Name		Bit 7	Bit 6	Bit 5	Bit 4	Bit 3	Bit 2	Bit 1	Bit 0
\$0143	CAN0BTR1	Read:	SAMP	TSEG22	TSEG21	TSEG20	TSEG13	TSEG12	TSEG11	TSEG10
		Write:								
\$0144	CAN0RFLG	Read:	WUPIF	CSCIF	RSTAT1	RSTAT0	TSTAT1	TSTAT0	OVRIF	RXF
		Write:								
\$0145	CAN0RIER	Read:	WUPIE	CSCIE	RSTATE1	RSTATE0	TSTATE1	TSTATE0	OVRIE	RXFIE
		Write:								
\$0146	CAN0TFLG	Read:	0	0	0	0	0	TXE2	TXE1	TXE0
		Write:								
\$0147	CAN0TIER	Read:	0	0	0	0	0	TXEIE2	TXEIE1	TXEIE0
		Write:								
\$0148	CAN0TARQ	Read:	0	0	0	0	0	ABTRQ2	ABTRQ1	ABTRQ0
		Write:								
\$0149	CAN0TAAK	Read:	0	0	0	0	0	ABTAK2	ABTAK1	ABTAK0
		Write:								
\$014A	CAN0TBSEL	Read:	0	0	0	0	0	TX2	TX1	TX0
		Write:								
\$014B	CAN0IDAC	Read:	0	0	IDAM1	IDAM0	0	IDHIT2	IDHIT1	IDHIT0
		Write:								
\$014C	Reserved	Read:	0	0	0	0	0	0	0	0
		Write:								
\$014D	Reserved	Read:	0	0	0	0	0	0	0	0
		Write:								
\$014E	CAN0RXERR	Read:	RXERR7	RXERR6	RXERR5	RXERR4	RXERR3	RXERR2	RXERR1	RXERR0
		Write:								
\$014F	CAN0TXERR	Read:	TXERR7	TXERR6	TXERR5	TXERR4	TXERR3	TXERR2	TXERR1	TXERR0
		Write:								
\$0150 - \$0153	CAN0IDAR0 - CAN0IDAR3	Read:	AC7	AC6	AC5	AC4	AC3	AC2	AC1	AC0
		Write:								
\$0154 - \$0157	CAN0IDMR0 - CAN0IDMR3	Read:	AM7	AM6	AM5	AM4	AM3	AM2	AM1	AM0
		Write:								
\$0158 - \$015B	CAN0IDAR4 - CAN0IDAR7	Read:	AC7	AC6	AC5	AC4	AC3	AC2	AC1	AC0
		Write:								
\$015C - \$015F	CAN0IDMR4 - CAN0IDMR7	Read:	AM7	AM6	AM5	AM4	AM3	AM2	AM1	AM0
		Write:								
\$0160 - \$016F	CAN0RXFG	Read:	BACKGROUND RECEIVE BUFFER see Table 1-2							
		Write:								
\$0170 - \$017F	CAN0TXFG	Read:	BACKGROUND TRANSMIT BUFFER see Table 1-2							
		Write:								

Table 1-2 Detailed MSCAN Foreground Receive and Transmit Buffer Layout

Address	Name		Bit 7	Bit 6	Bit 5	Bit 4	Bit 3	Bit 2	Bit 1	Bit 0
	Extended ID	Read:	ID28	ID27	ID26	ID25	ID24	ID23	ID22	ID21
\$xxx0	Standard ID	Read:	ID10	ID9	ID8	ID7	ID6	ID5	ID4	ID3
	CANxRIDR0	Write:								
	Extended ID	Read:	ID20	ID19	ID18	SRR=1	IDE=1	ID17	ID16	ID15
\$xxx1	Standard ID	Read:	ID2	ID1	ID0	RTR	IDE=0			
	CANxRIDR1	Write:								

**Table 1-2 Detailed MSCAN Foreground Receive and Transmit Buffer Layout**

Address	Name		Bit 7	Bit 6	Bit 5	Bit 4	Bit 3	Bit 2	Bit 1	Bit 0
\$xxx2	Extended ID	Read:	ID14	ID13	ID12	ID11	ID10	ID9	ID8	ID7
	Standard ID	Read:								
\$xxx3	CANxRIDR2	Write:								
	Extended ID	Read:	ID6	ID5	ID4	ID3	ID2	ID1	ID0	RTR
\$xxx4-\$xxxB	CANxRDSR0 -	Read:	DB7	DB6	DB5	DB4	DB3	DB2	DB1	DB0
	CANxRDSR7	Write:								
\$xxxC	CANRxDLR	Read:					DLC3	DLC2	DLC1	DLC0
		Write:								
\$xxxD	Reserved	Read:								
		Write:								
\$xxxE	CANxRTSRH	Read:	TSR15	TSR14	TSR13	TSR12	TSR11	TSR10	TSR9	TSR8
		Write:								
\$xxxF	CANxRTSRL	Read:	TSR7	TSR6	TSR5	TSR4	TSR3	TSR2	TSR1	TSR0
		Write:								
\$xx10	Extended ID	Read:	ID28	ID27	ID26	ID25	ID24	ID23	ID22	ID21
	CANxTIDR0	Write:								
\$xx10	Standard ID	Read:	ID10	ID9	ID8	ID7	ID6	ID5	ID4	ID3
		Write:								
\$xx10	Extended ID	Read:	ID20	ID19	ID18	SRR=1	IDE=1	ID17	ID16	ID15
	CANxTIDR1	Write:								
\$xx12	Standard ID	Read:	ID2	ID1	ID0	RTR	IDE=0			
		Write:								
\$xx12	Extended ID	Read:	ID14	ID13	ID12	ID11	ID10	ID9	ID8	ID7
	CANxTIDR2	Write:								
\$xx13	Standard ID	Read:								
		Write:								
\$xx13	Extended ID	Read:	ID6	ID5	ID4	ID3	ID2	ID1	ID0	RTR
	CANxTIDR3	Write:								
\$xx14-\$xx1B	CANxTDSR0 -	Read:	DB7	DB6	DB5	DB4	DB3	DB2	DB1	DB0
	CANxTDSR7	Write:								
\$xx1C	CANxTDLR	Read:					DLC3	DLC2	DLC1	DLC0
		Write:								
\$xx1D	CONxTTBPR	Read:	PRI07	PRI06	PRI05	PRI04	PRI03	PRI02	PRI01	PRI00
		Write:								
\$xx1E	CANxTTSRH	Read:	TSR15	TSR14	TSR13	TSR12	TSR11	TSR10	TSR9	TSR8
		Write:								
\$xx1F	CANxTTSRL	Read:	TSR7	TSR6	TSR5	TSR4	TSR3	TSR2	TSR1	TSR0
		Write:								

**\$0180 - \$01BF****CAN1 (Motorola Scalable CAN - MSCAN)**

Address	Name		Bit 7	Bit 6	Bit 5	Bit 4	Bit 3	Bit 2	Bit 1	Bit 0
\$0180	CAN1CTL0	Read:	RXFRM	RXACT	CSWAI	SYNCH	TIME	WUPE	SLPRQ	INITRQ
		Write:								
\$0181	CAN1CTL1	Read:	CANE	CLKSRC	LOOPB	LISTEN	0	WUPM	SLPAK	INITAK
		Write:								
\$0182	CAN1BTR0	Read:	SJW1	SJW0	BRP5	BRP4	BRP3	BRP2	BRP1	BRP0
		Write:								
\$0183	CAN1BTR1	Read:	SAMP	TSEG22	TSEG21	TSEG20	TSEG13	TSEG12	TSEG11	TSEG10
		Write:								
\$0184	CAN1RFLG	Read:	WUPIF	CSCIF	RSTAT1	RSTAT0	TSTAT1	TSTAT0	OVRIF	RXF
		Write:								
\$0185	CAN1RIER	Read:	WUPIE	CSCIE	RSTATE1	RSTATE0	TSTATE1	TSTATE0	OVRIE	RXFIE
		Write:								
\$0186	CAN1TFLG	Read:	0	0	0	0	0	TXE2	TXE1	TXE0
		Write:								
\$0187	CAN1TIER	Read:	0	0	0	0	0	TXEIE2	TXEIE1	TXEIE0
		Write:								
\$0188	CAN1TARQ	Read:	0	0	0	0	0	ABTRQ2	ABTRQ1	ABTRQ0
		Write:								
\$0189	CAN1TAAK	Read:	0	0	0	0	0	ABTAK2	ABTAK1	ABTAK0
		Write:								
\$018A	CAN1TBSEL	Read:	0	0	0	0	0	TX2	TX1	TX0
		Write:								
\$018B	CAN1IDAC	Read:	0	0	IDAM1	IDAM0	0	IDHIT2	IDHIT1	IDHIT0
		Write:								
\$018C	Reserved	Read:	0	0	0	0	0	0	0	0
		Write:								
\$018D	Reserved	Read:	0	0	0	0	0	0	0	0
		Write:								
\$018E	CAN1RXERR	Read:	RXERR7	RXERR6	RXERR5	RXERR4	RXERR3	RXERR2	RXERR1	RXERR0
		Write:								
\$018F	CAN1TXERR	Read:	TXERR7	TXERR6	TXERR5	TXERR4	TXERR3	TXERR2	TXERR1	TXERR0
		Write:								
\$0190	CAN1IDAR0	Read:	AC7	AC6	AC5	AC4	AC3	AC2	AC1	AC0
		Write:								
\$0191	CAN1IDAR1	Read:	AC7	AC6	AC5	AC4	AC3	AC2	AC1	AC0
		Write:								
\$0192	CAN1IDAR2	Read:	AC7	AC6	AC5	AC4	AC3	AC2	AC1	AC0
		Write:								
\$0193	CAN1IDAR3	Read:	AC7	AC6	AC5	AC4	AC3	AC2	AC1	AC0
		Write:								
\$0194	CAN1IDMR0	Read:	AM7	AM6	AM5	AM4	AM3	AM2	AM1	AM0
		Write:								
\$0195	CAN1IDMR1	Read:	AM7	AM6	AM5	AM4	AM3	AM2	AM1	AM0
		Write:								
\$0196	CAN1IDMR2	Read:	AM7	AM6	AM5	AM4	AM3	AM2	AM1	AM0
		Write:								
\$0197	CAN1IDMR3	Read:	AM7	AM6	AM5	AM4	AM3	AM2	AM1	AM0
		Write:								
\$0198	CAN1IDAR4	Read:	AC7	AC6	AC5	AC4	AC3	AC2	AC1	AC0
		Write:								

**\$0180 - \$01BF**

**CAN1 (Motorola Scalable CAN - MSCAN)**

Address	Name		Bit 7	Bit 6	Bit 5	Bit 4	Bit 3	Bit 2	Bit 1	Bit 0
\$0199	CAN1IDAR5	Read: Write:	AC7	AC6	AC5	AC4	AC3	AC2	AC1	AC0
\$019A	CAN1IDAR6	Read: Write:	AC7	AC6	AC5	AC4	AC3	AC2	AC1	AC0
\$019B	CAN1IDAR7	Read: Write:	AC7	AC6	AC5	AC4	AC3	AC2	AC1	AC0
\$019C	CAN1IDMR4	Read: Write:	AM7	AM6	AM5	AM4	AM3	AM2	AM1	AM0
\$019D	CAN1IDMR5	Read: Write:	AM7	AM6	AM5	AM4	AM3	AM2	AM1	AM0
\$019E	CAN1IDMR6	Read: Write:	AM7	AM6	AM5	AM4	AM3	AM2	AM1	AM0
\$019F	CAN1IDMR7	Read: Write:	AM7	AM6	AM5	AM4	AM3	AM2	AM1	AM0
\$01A0 - \$01AF	CAN1RXFG	Read: Write:	FOREGROUND RECEIVE BUFFER see <b>Table 1-2</b>							
\$01B0 - \$01BF	CAN1TXFG	Read: Write:	FOREGROUND TRANSMIT BUFFER see <b>Table 1-2</b>							

**\$0240 - \$027F**

**PIM (Port Integration Module PIM\_9DP256)**

Address	Name		Bit 7	Bit 6	Bit 5	Bit 4	Bit 3	Bit 2	Bit 1	Bit 0
\$0240	PTT	Read: Write:	PTT7	PTT6	PTT5	PTT4	PTT3	PTT2	PTT1	PTT0
\$0241	PTIT	Read: Write:	PTIT7	PTIT6	PTIT5	PTIT4	PTIT3	PTIT2	PTIT1	PTIT0
\$0242	DDRT	Read: Write:	DDRT7	DDRT7	DDRT5	DDRT4	DDRT3	DDRT2	DDRT1	DDRT0
\$0243	RDRT	Read: Write:	RDRT7	RDRT6	RDRT5	RDRT4	RDRT3	RDRT2	RDRT1	RDRT0
\$0244	PERT	Read: Write:	PERT7	PERT6	PERT5	PERT4	PERT3	PERT2	PERT1	PERT0
\$0245	PPST	Read: Write:	PPST7	PPST6	PPST5	PPST4	PPST3	PPST2	PPST1	PPST0
\$0246	Reserved	Read: Write:	0	0	0	0	0	0	0	0
\$0247	Reserved	Read: Write:	0	0	0	0	0	0	0	0
\$0248	PTS	Read: Write:	PTS7	PTS6	PTS5	PTS4	PTS3	PTS2	PTS1	PTS0
\$0249	PTIS	Read: Write:	PTIS7	PTIS6	PTIS5	PTIS4	PTIS3	PTIS2	PTIS1	PTIS0
\$024A	DDRS	Read: Write:	DDRS7	DDRS7	DDRS5	DDRS4	DDRS3	DDRS2	DDRS1	DDRS0
\$024B	RDRS	Read: Write:	RDRS7	RDRS6	RDRS5	RDRS4	RDRS3	RDRS2	RDRS1	RDRS0
\$024C	PERS	Read: Write:	PERS7	PERS6	PERS5	PERS4	PERS3	PERS2	PERS1	PERS0

## \$0240 - \$027F

## PIM (Port Integration Module PIM\_9DP256)

Address	Name		Bit 7	Bit 6	Bit 5	Bit 4	Bit 3	Bit 2	Bit 1	Bit 0
\$024D	PPSS	Read:	PPSS7	PPSS6	PPSS5	PPSS4	PPSS3	PPSS2	PPSS1	PPSS0
		Write:								
\$024E	WOMS	Read:	WOMS7	WOMS6	WOMS5	WOMS4	WOMS3	WOMS2	WOMS1	WOMS0
		Write:								
\$024F	Reserved	Read:	0	0	0	0	0	0	0	0
		Write:								
\$0250	PTM	Read:	PTM7	PTM6	PTM5	PTM4	PTM3	PTM2	PTM1	PTM0
		Write:								
\$0251	PTIM	Read:	PTIM7	PTIM6	PTIM5	PTIM4	PTIM3	PTIM2	PTIM1	PTIM0
		Write:								
\$0252	DDRM	Read:	DDRM7	DDRM6	DDRM5	DDRM4	DDRM3	DDRM2	DDRM1	DDRM0
		Write:								
\$0253	RDRM	Read:	RDRM7	RDRM6	RDRM5	RDRM4	RDRM3	RDRM2	RDRM1	RDRM0
		Write:								
\$0254	PERM	Read:	PERM7	PERM6	PERM5	PERM4	PERM3	PERM2	PERM1	PERM0
		Write:								
\$0255	PPSM	Read:	PPSM7	PPSM6	PPSM5	PPSM4	PPSM3	PPSM2	PPSM1	PPSM0
		Write:								
\$0256	WOMM	Read:	WOMM7	WOMM6	WOMM5	WOMM4	WOMM3	WOMM2	WOMM1	WOMM0
		Write:								
\$0257	MODRR	Read:	0	MODRR6	MODRR5	MODRR4	MODRR3	MODRR2	MODRR1	MODRR0
		Write:								
\$0258	PTP	Read:	PTP7	PTP6	PTP5	PTP4	PTP3	PTP2	PTP1	PTP0
		Write:								
\$0259	PTIP	Read:	PTIP7	PTIP6	PTIP5	PTIP4	PTIP3	PTIP2	PTIP1	PTIP0
		Write:								
\$025A	DDRP	Read:	DDRP7	DDRP6	DDRP5	DDRP4	DDRP3	DDRP2	DDRP1	DDRP0
		Write:								
\$025B	RDRP	Read:	RDRP7	RDRP6	RDRP5	RDRP4	RDRP3	RDRP2	RDRP1	RDRP0
		Write:								
\$025C	PERP	Read:	PERP7	PERP6	PERP5	PERP4	PERP3	PERP2	PERP1	PERP0
		Write:								
\$025D	PPSP	Read:	PPSP7	PPSP6	PPSP5	PPSP4	PPSP3	PPSP2	PPSP1	PPSP0
		Write:								
\$025E	PIEP	Read:	PIEP7	PIEP6	PIEP5	PIEP4	PIEP3	PIEP2	PIEP1	PIEP0
		Write:								
\$025F	PIFP	Read:	PIFP7	PIFP6	PIFP5	PIFP4	PIFP3	PIFP2	PIFP1	PIFP0
		Write:								
\$0260	PTH	Read:	PTH7	PTH6	PTH5	PTH4	PTH3	PTH2	PTH1	PTH0
		Write:								
\$0261	PTIH	Read:	PTIH7	PTIH6	PTIH5	PTIH4	PTIH3	PTIH2	PTIH1	PTIH0
		Write:								
\$0262	DDRH	Read:	DDRH7	DDRH6	DDRH5	DDRH4	DDRH3	DDRH2	DDRH1	DDRH0
		Write:								
\$0263	RDRH	Read:	RDRH7	RDRH6	RDRH5	RDRH4	RDRH3	RDRH2	RDRH1	RDRH0
		Write:								
\$0264	PERH	Read:	PERH7	PERH6	PERH5	PERH4	PERH3	PERH2	PERH1	PERH0
		Write:								
\$0265	PPSH	Read:	PPSH7	PPSH6	PPSH5	PPSH4	PPSH3	PPSH2	PPSH1	PPSH0
		Write:								

**\$0240 - \$027F**

**PIM (Port Integration Module PIM\_9DP256)**

Address	Name		Bit 7	Bit 6	Bit 5	Bit 4	Bit 3	Bit 2	Bit 1	Bit 0
\$0266	PIEH	Read: Write:	PIEH7	PIEH6	PIEH5	PIEH4	PIEH3	PIEH2	PIEH1	PIEH0
\$0267	PIFH	Read: Write:	PIFH7	PIFH6	PIFH5	PIFH4	PIFH3	PIFH2	PIFH1	PIFH0
\$0268	PTJ	Read: Write:	PTJ7	PTJ6	0	0	0	0	PTJ1	PTJ0
\$0269	PTIJ	Read: Write:	PTIJ7	PTIJ6	0	0	0	0	PTIJ1	PTIJ0
\$026A	DDRJ	Read: Write:	DDRJ7	DDRJ7	0	0	0	0	DDRJ1	DDRJ0
\$026B	RDRJ	Read: Write:	RDRJ7	RDRJ6	0	0	0	0	RDRJ1	RDRJ0
\$026C	PERJ	Read: Write:	PERJ7	PERJ6	0	0	0	0	PERJ1	PERJ0
\$026D	PPSJ	Read: Write:	PPSJ7	PPSJ6	0	0	0	0	PPSJ1	PPSJ0
\$026E	PIEJ	Read: Write:	PIEJ7	PIEJ6	0	0	0	0	PIEJ1	PIEJ0
\$026F	PIFJ	Read: Write:	PIFJ7	PIFJ6	0	0	0	0	PIFJ1	PIFJ0
\$0270 - \$027F	Reserved	Read:								

**\$0280 - \$02BF**

**CAN4 (Motorola Scalable CAN - MSCAN)**

Address	Name		Bit 7	Bit 6	Bit 5	Bit 4	Bit 3	Bit 2	Bit 1	Bit 0
\$0280	CAN4CTL0	Read: Write:	RXFRM	RXACT	CSWAI	SYNCH	TIME	WUPE	SLPRQ	INITRQ
\$0281	CAN4CTL1	Read: Write:	CANE	CLKSRC	LOOPB	LISTEN	0	WUPM	SLPAK	INITAK
\$0282	CAN4BTR0	Read: Write:	SJW1	SJW0	BRP5	BRP4	BRP3	BRP2	BRP1	BRP0
\$0283	CAN4BTR1	Read: Write:	SAMP	TSEG22	TSEG21	TSEG20	TSEG13	TSEG12	TSEG11	TSEG10
\$0284	CAN4RFLG	Read: Write:	WUPIF	CSCIF	RSTAT1	RSTAT0	TSTAT1	TSTAT0	OVRIF	RXF
\$0285	CAN4RIER	Read: Write:	WUPIE	CSCIE	RSTATE1	RSTATE0	TSTATE1	TSTATE0	OVRIE	RXFIE
\$0286	CAN4TFLG	Read: Write:	0	0	0	0	0	TXE2	TXE1	TXE0
\$0287	CAN4TIER	Read: Write:	0	0	0	0	0	TXEIE2	TXEIE1	TXEIE0
\$0288	CAN4TARQ	Read: Write:	0	0	0	0	0	ABTRQ2	ABTRQ1	ABTRQ0
\$0289	CAN4TAAK	Read: Write:	0	0	0	0	0	ABTAK2	ABTAK1	ABTAK0
\$028A	CAN4TBSEL	Read: Write:	0	0	0	0	0	TX2	TX1	TX0
\$028B	CAN4IDAC	Read: Write:	0	0	IDAM1	IDAM0	0	IDHIT2	IDHIT1	IDHIT0



## \$0280 - \$02BF

## CAN4 (Motorola Scalable CAN - MSCAN)

Address	Name		Bit 7	Bit 6	Bit 5	Bit 4	Bit 3	Bit 2	Bit 1	Bit 0
\$028C	Reserved	Read:	0	0	0	0	0	0	0	0
		Write:								
\$028D	Reserved	Read:	0	0	0	0	0	0	0	0
		Write:								
\$028E	CAN4RXERR	Read:	RXERR7	RXERR6	RXERR5	RXERR4	RXERR3	RXERR2	RXERR1	RXERR0
		Write:								
\$028F	CAN4TXERR	Read:	TXERR7	TXERR6	TXERR5	TXERR4	TXERR3	TXERR2	TXERR1	TXERR0
		Write:								
\$0290	CAN4IDAR0	Read:	AC7	AC6	AC5	AC4	AC3	AC2	AC1	AC0
		Write:								
\$0291	CAN4IDAR1	Read:	AC7	AC6	AC5	AC4	AC3	AC2	AC1	AC0
		Write:								
\$0292	CAN4IDAR2	Read:	AC7	AC6	AC5	AC4	AC3	AC2	AC1	AC0
		Write:								
\$0293	CAN4IDAR3	Read:	AC7	AC6	AC5	AC4	AC3	AC2	AC1	AC0
		Write:								
\$0294	CAN4IDMR0	Read:	AM7	AM6	AM5	AM4	AM3	AM2	AM1	AM0
		Write:								
\$0295	CAN4IDMR1	Read:	AM7	AM6	AM5	AM4	AM3	AM2	AM1	AM0
		Write:								
\$0296	CAN4IDMR2	Read:	AM7	AM6	AM5	AM4	AM3	AM2	AM1	AM0
		Write:								
\$0297	CAN4IDMR3	Read:	AM7	AM6	AM5	AM4	AM3	AM2	AM1	AM0
		Write:								
\$0298	CAN4IDAR4	Read:	AC7	AC6	AC5	AC4	AC3	AC2	AC1	AC0
		Write:								
\$0299	CAN4IDAR5	Read:	AC7	AC6	AC5	AC4	AC3	AC2	AC1	AC0
		Write:								
\$029A	CAN4IDAR6	Read:	AC7	AC6	AC5	AC4	AC3	AC2	AC1	AC0
		Write:								
\$029B	CAN4IDAR7	Read:	AC7	AC6	AC5	AC4	AC3	AC2	AC1	AC0
		Write:								
\$029C	CAN4IDMR4	Read:	AM7	AM6	AM5	AM4	AM3	AM2	AM1	AM0
		Write:								
\$029D	CAN4IDMR5	Read:	AM7	AM6	AM5	AM4	AM3	AM2	AM1	AM0
		Write:								
\$029E	CAN4IDMR6	Read:	AM7	AM6	AM5	AM4	AM3	AM2	AM1	AM0
		Write:								
\$029F	CAN4IDMR7	Read:	AM7	AM6	AM5	AM4	AM3	AM2	AM1	AM0
		Write:								
\$02A0 - \$02AF	CAN4RXFG	Read:	BACKGROUND RECEIVE BUFFER see <b>Table 1-2</b>							
		Write:								
\$02B0 - \$02BF	CAN4TXFG	Read:	BACKGROUND TRANSMIT BUFFER see <b>Table 1-2</b>							
		Write:								

**\$02C0 - \$03FF****Reserved space**

Address	Name		Bit 7	Bit 6	Bit 5	Bit 4	Bit 3	Bit 2	Bit 1	Bit 0
\$02C0	Reserved	Read:	0	0	0	0	0	0	0	0
-\$03FF		Write:								

## 1.7 Part ID Assignments

The part ID is located in two 8-bit registers PARTIDH and PARTIDL (addresses \$001A and \$001B after reset). The read-only value is a unique part ID for each revision of the chip. **Table 1-3** shows the assigned part ID number.

**Table 1-3 Assigned Part ID Numbers**

Device	Mask Set Number	Part ID <sup>1</sup>
MC9S12DT256	0L91N	\$0030
MC9S12DT256	1L91N	\$0031
MC9S12DT256	3L91N	\$0032
MC9S12DT256	4L91N	\$0034
MC9S12DT256	0L01Y	\$0033

NOTES:

- The coding is as follows:  
 Bit 15-12: Major family identifier  
 Bit 11-8: Minor family identifier  
 Bit 7-4: Major mask set revision number including FAB transfers  
 Bit 3-0: Minor - non full - mask set revision

The device memory sizes are located in two 8-bit registers MEMSIZ0 and MEMSIZ1 (addresses \$001C and \$001D after reset). **Table 1-4** shows the read-only values of these registers. Refer to section Module Mapping and Control (MMC) of HCS12 Core User Guide for further details.

**Table 1-4 Memory size registers**

Register name	Value
MEMSIZ0	\$25
MEMSIZ1	\$81

## Section 2 Signal Description

This section describes signals that connect off-chip. It includes a pinout diagram, a table of signal properties, and detailed discussion of signals. It is built from the signal description sections of the Block User Guides of the individual IP blocks on the device.

### 2.1 Device Pinout

The MC9S12DT256/MC9S12DJ256/MC9S12DG256 and MC9S12A256 is available in a 112-pin low profile quad flat pack (LQFP) and MC9S12DJ256/MC9S12DG256 and MC9S12A256 is also available in a 80-pin quad flat pack (QFP). Most pins perform two or more functions, as described in the Signal Descriptions. **Figure 2-1** and **Figure 2-2** show the pin assignments.

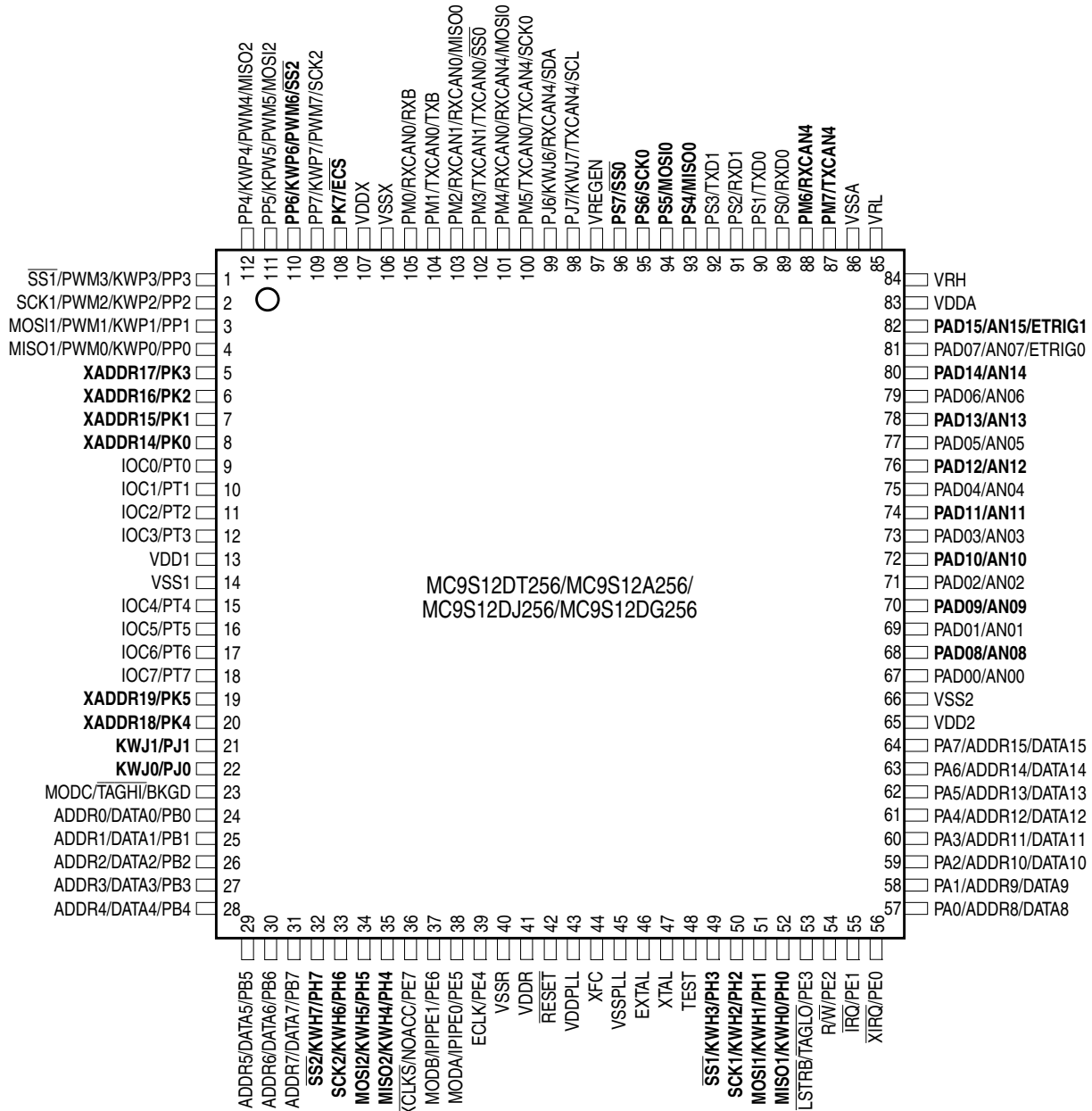

Signals shown in **Bold** are not available on the 80 Pin Package

Figure 2-1 Pin Assignments in 112-pin LQFP

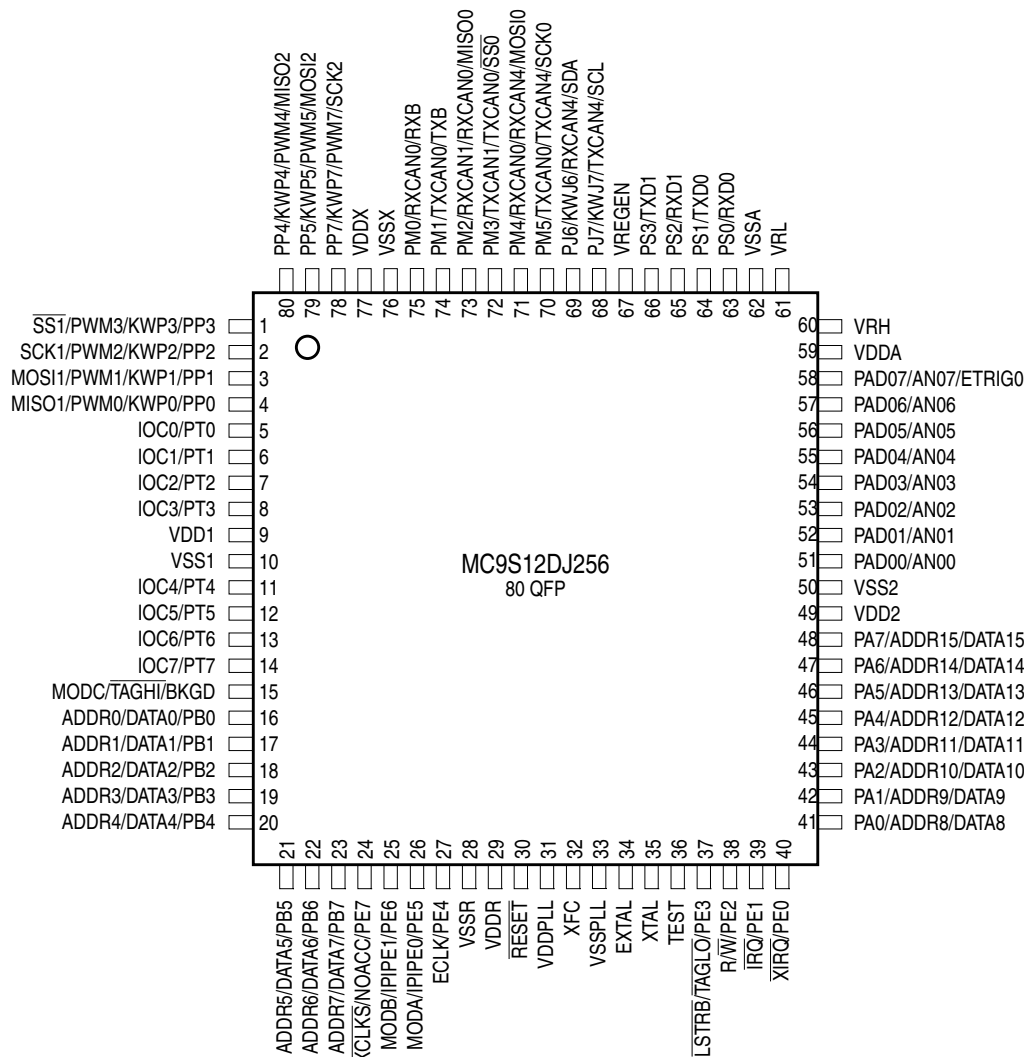

Figure 2-2 Pin Assignments in 80-pin QFP for MC9S12DJ256

## 2.2 Signal Properties Summary

Table 2-1 summarizes the pin functionality. Signals shown in **bold** are not available in the 80 pin package.

Table 2-1 Signal Properties

Pin Name Funct. 1	Pin Name Funct. 2	Pin Name Funct. 3	Pin Name Funct. 4	Pin Name Funct. 5	Power Supply	Internal Pull Resistor		Description
						CTRL	Reset State	
EXTAL	—	—	—	—	VDDPLL	NA	NA	Oscillator Pins
XTAL	—	—	—	—	VDDPLL	NA	NA	
RESET	—	—	—	—	VDDR	None	None	External Reset
TEST	—	—	—	—	N.A.	NA	NA	Test Input
VREGEN	—	—	—	—	VDDX	NA	NA	Voltage Regulator Enable Input
XFC	—	—	—	—	VDDPLL	NA	NA	PLL Loop Filter
BKGD	$\overline{\text{TAGH}}$	MODC	—	—	VDDR	Always Up	Up	Background Debug, Tag High, Mode Input
PAD[15]	AN1[7]	ETRIG1	—	—	VDDA	None	None	Port AD Input, Analog Input AN7 of ATD1, External Trigger Input of ATD1
PAD[14:8]	AN1[6:0]	—	—	—	VDDA	None	None	Port AD Inputs, Analog Inputs AN[6:0] of ATD1
PAD[7]	AN0[7]	ETRIG0	—	—	VDDA	None	None	Port AD Input, Analog Input AN7 of ATD0, External Trigger Input of ATD0
PAD[6:0]	AN0[6:0]	—	—	—	VDDA	None	None	Port AD Inputs, Analog Inputs AN[6:0] of ATD0
PA[7:0]	ADDR[15:8]/ DATA[15:8]	—	—	—	VDDR	PUCR	Disabled	Port A I/O, Multiplexed Address/Data
PB[7:0]	ADDR[7:0]/ DATA[7:0]	—	—	—	VDDR	PUCR	Disabled	Port B I/O, Multiplexed Address/Data
PE7	NOACC	$\overline{\text{XCLKS}}$	—	—	VDDR	PUCR	Up	Port E I/O, Access, Clock Select
PE6	IPIPE1	MODB	—	—	VDDR	While RESET pin is low: Down		Port E I/O, Pipe Status, Mode Input
PE5	IPIPE0	MODA	—	—	VDDR	While RESET pin is low: Down		Port E I/O, Pipe Status, Mode Input
PE4	ECLK	—	—	—	VDDR	PUCR	Up	Port E I/O, Bus Clock Output
PE3	$\overline{\text{LSTRB}}$	$\overline{\text{TAGLO}}$	—	—	VDDR	PUCR	Up	Port E I/O, Byte Strobe, Tag Low
PE2	R/ $\overline{\text{W}}$	—	—	—	VDDR	PUCR	Up	Port E I/O, R/ $\overline{\text{W}}$ in expanded modes
PE1	$\overline{\text{IRQ}}$	—	—	—	VDDR	PUCR	Up	Port E Input, Maskable Interrupt
PE0	$\overline{\text{XIRQ}}$	—	—	—	VDDR	PUCR	Up	Port E Input, Non Maskable Interrupt
PH7	KWH7	$\overline{\text{SS2}}$	—	—	VDDR	PERH/ PPSH	Disabled	Port H I/O, Interrupt, $\overline{\text{SS}}$ of SPI2
PH6	KWH6	SCK2	—	—	VDDR	PERH/ PPSH	Disabled	Port H I/O, Interrupt, SCK of SPI2
PH5	KWH5	MOSI2	—	—	VDDR	PERH/ PPSH	Disabled	Port H I/O, Interrupt, MOSI of SPI2

Pin Name Funct. 1	Pin Name Funct. 2	Pin Name Funct. 3	Pin Name Funct. 4	Pin Name Funct. 5	Power Supply	Internal Pull Resistor		Description
						CTRL	Reset State	
PH4	KWH4	MISO2	—	—	VDDR	PERH/ PPSH	Disabled	Port H I/O, Interrupt, MISO of SPI2
PH3	KWH3	$\overline{SS}1$	—	—	VDDR	PERH/ PPSH	Disabled	Port H I/O, Interrupt, $\overline{SS}$ of SPI1
PH2	KWH2	SCK1	—	—	VDDR	PERH/ PPSH	Disabled	Port H I/O, Interrupt, SCK of SPI1
PH1	KWH1	MOSI1	—	—	VDDR	PERH/ PPSH	Disabled	Port H I/O, Interrupt, MOSI of SPI1
PH0	KWH0	MISO1	—	—	VDDR	PERH/ PPSH	Disabled	Port H I/O, Interrupt, MISO of SPI1
PJ7	KWJ7	TXCAN4	SCL	TXCAN0	VDDX	PERJ/ PPSJ	Up	Port J I/O, Interrupt, TX of CAN4, SCL of IIC, TX of CAN0
PJ6	KWJ6	RXCAN4	SDA	RXCAN0	VDDX	PERJ/ PPSJ	Up	Port J I/O, Interrupt, RX of CAN4, SDA of IIC, RX of CAN0
PJ[1:0]	KWJ[1:0]	—	—	—	VDDX	PERJ/ PSJ	Up	Port J I/O, Interrupts
PK7	ECS	ROMONE	—	—	VDDX	PUCR	Up	Port K I/O, Emulation Chip Select, ROM On Enable
PK[5:0]	XADDR [19:14]	—	—	—	VDDX	PUCR	Up	Port K I/O, Extended Addresses
PM7	TXCAN4	—	—	—	VDDX	PERM/ PPSM	Disabled	Port M I/O, TX of CAN4
PM6	RXCAN4	—	—	—	VDDX	PERM/ PPSM	Disabled	Port M I/O RX of CAN4
PM5	TXCAN0	TXCAN4	SCK0	—	VDDX	PERM/ PPSM	Disabled	Port M I/O CAN0, CAN4, SCK of SPI0
PM4	RXCAN0	RXCAN4	MOSI0	—	VDDX	PERM/ PPSM	Disabled	Port M I/O, CAN0, CAN4, MOSI of SPI0
PM3	TXCAN1	TXCAN0	—	$\overline{SS}0$	VDDX	PERM/ PPSM	Disabled	Port M I/O, TX of CAN1, CAN0, $\overline{SS}$ of SPI0
PM2	RXCAN1	RXCAN0	—	MISO0	VDDX	PERM/ PPSM	Disabled	Port M I/O, RX of CAN1, CAN0, MISO of SPI0
PM1	TXCAN0	TXB	—	—	VDDX	PERM/ PPSM	Disabled	Port M I/O, TX of CAN0, TX of BDLC
PM0	RXCAN0	RXB	—	—	VDDX	PERM/ PPSM	Disabled	Port M I/O, RX of CAN0, RX of BDLC
PP7	KWP7	PWM7	SCK2	—	VDDX	PERP/ PPSP	Disabled	Port P I/O, Interrupt, Channel 7 of PWM, SCK of SPI2
PP6	KWP6	PWM6	$\overline{SS}2$	—	VDDX	PERP/ PPSP	Disabled	Port P I/O, Interrupt, Channel 6 of PWM, $\overline{SS}$ of SPI2
PP5	KWP5	PWM5	MOSI2	—	VDDX	PERP/ PPSP	Disabled	Port P I/O, Interrupt, Channel 5 of PWM, MOSI of SPI2

Pin Name Funct. 1	Pin Name Funct. 2	Pin Name Funct. 3	Pin Name Funct. 4	Pin Name Funct. 5	Power Supply	Internal Pull Resistor		Description
						CTRL	Reset State	
PP4	KWP4	PWM4	MISO2	—	VDDX	PERP/ PPSP	Disabled	Port P I/O, Interrupt, Channel 4 of PWM, MISO2 of SPI2
PP3	KWP3	PWM3	SS1	—	VDDX	PERP/ PPSP	Disabled	Port P I/O, Interrupt, Channel 3 of PWM, SS of SPI1
PP2	KWP2	PWM2	SCK1	—	VDDX	PERP/ PPSP	Disabled	Port P I/O, Interrupt, Channel 2 of PWM, SCK of SPI1
PP1	KWP1	PWM1	MOSI1	—	VDDX	PERP/ PPSP	Disabled	Port P I/O, Interrupt, Channel 1 of PWM, MOSI of SPI1
PP0	KWP0	PWM0	MISO1	—	VDDX	PERP/ PPSP	Disabled	Port P I/O, Interrupt, Channel 0 of PWM, MISO2 of SPI1
<b>PS7</b>	<b>SS0</b>	—	—	—	<b>VDDX</b>	<b>PERS/ PPSS</b>	<b>Up</b>	<b>Port S I/O, SS of SPI0</b>
<b>PS6</b>	<b>SCK0</b>	—	—	—	<b>VDDX</b>	<b>PERS/ PPSS</b>	<b>Up</b>	<b>Port S I/O, SCK of SPI0</b>
<b>PS5</b>	<b>MOSI0</b>	—	—	—	<b>VDDX</b>	<b>PERS/ PPSS</b>	<b>Up</b>	<b>Port S I/O, MOSI of SPI0</b>
<b>PS4</b>	<b>MISO0</b>	—	—	—	<b>VDDX</b>	<b>PERS/ PPSS</b>	<b>Up</b>	<b>Port S I/O, MISO of SPI0</b>
PS3	TXD1	—	—	—	VDDX	PERS/ PPSS	Up	Port S I/O, TXD of SCI1
PS2	RXD1	—	—	—	VDDX	PERS/ PPSS	Up	Port S I/O, RXD of SCI1
PS1	TXD0	—	—	—	VDDX	PERS/ PPSS	Up	Port S I/O, TXD of SCI0
PS0	RXD0	—	—	—	VDDX	PERS/ PPSS	Up	Port S I/O, RXD of SCI0
PT[7:0]	IOC[7:0]	—	—	—	VDDX	PERT/ PPST	Disabled	Port T I/O, Timer channels

## 2.3 Detailed Signal Descriptions

### 2.3.1 EXTAL, XTAL — Oscillator Pins

EXTAL and XTAL are the crystal driver and external clock pins. On reset all the device clocks are derived from the EXTAL input frequency. XTAL is the crystal output.

### 2.3.2 RESET — External Reset Pin

An active low bidirectional control signal, it acts as an input to initialize the MCU to a known start-up state, and an output when an internal MCU function causes a reset.



### 2.3.3 TEST — Test Pin

This input only pin is reserved for test.

**NOTE:** The TEST pin must be tied to VSS in all applications.

### 2.3.4 VREGEN — Voltage Regulator Enable Pin

This input only pin enables or disables the on-chip voltage regulator.

### 2.3.5 XFC — PLL Loop Filter Pin

PLL loop filter. Please ask your Motorola representative for the interactive application note to compute PLL loop filter elements. Any current leakage on this pin must be avoided.

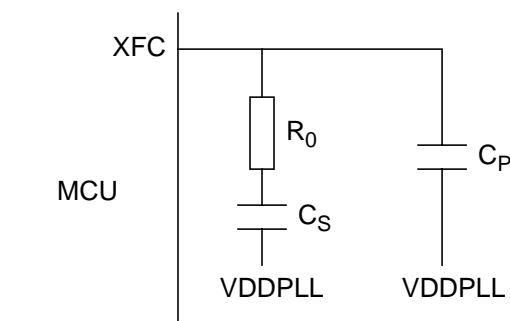

Figure 2-3 PLL Loop Filter Connections

### 2.3.6 BKGD / $\overline{\text{TAGHI}}$ / MODC — Background Debug, Tag High, and Mode Pin

The BKGD/ $\overline{\text{TAGHI}}$ /MODC pin is used as a pseudo-open-drain pin for the background debug communication. In MCU expanded modes of operation when instruction tagging is on, an input low on this pin during the falling edge of E-clock tags the high half of the instruction word being read into the instruction queue. It is used as a MCU operating mode select pin during reset. The state of this pin is latched to the MODC bit at the rising edge of  $\overline{\text{RESET}}$ . This pin has a permanently enabled pull-up device.

### 2.3.7 PAD15 / AN15 / ETRIG1 — Port AD Input Pin of ATD1

PAD15 is a general purpose input pin and analog input AN7 of the analog to digital converter ATD1. It can act as an external trigger input for the ATD1.

### 2.3.8 PAD[14:08] / AN[14:08] — Port AD Input Pins of ATD1

PAD14 - PAD08 are general purpose input pins and analog inputs AN[6:0] of the analog to digital converter ATD1.

### 2.3.9 PAD7 / AN07 / ETRIG0 — Port AD Input Pin of ATD0

PAD7 is a general purpose input pin and analog input AN7 of the analog to digital converter ATD0. It can act as an external trigger input for the ATD0.

### 2.3.10 PAD[06:00] / AN[06:00] — Port AD Input Pins of ATD0

PAD06 - PAD00 are general purpose input pins and analog inputs AN[6:0] of the analog to digital converter ATD0.

### 2.3.11 PA[7:0] / ADDR[15:8] / DATA[15:8] — Port A I/O Pins

PA7-PA0 are general purpose input or output pins. In MCU expanded modes of operation, these pins are used for the multiplexed external address and data bus.

### 2.3.12 PB[7:0] / ADDR[7:0] / DATA[7:0] — Port B I/O Pins

PB7-PB0 are general purpose input or output pins. In MCU expanded modes of operation, these pins are used for the multiplexed external address and data bus.

### 2.3.13 PE7 / NOACC / $\overline{\text{XCLKS}}$ — Port E I/O Pin 7

PE7 is a general purpose input or output pin. During MCU expanded modes of operation, the NOACC signal, when enabled, is used to indicate that the current bus cycle is an unused or “free” cycle. This signal will assert when the CPU is not using the bus. The  $\overline{\text{XCLKS}}$  is an input signal which controls whether a crystal in combination with the internal Colpitts (low power) oscillator is used or whether Pierce oscillator/external clock circuitry is used. The state of this pin is latched at the rising edge of  $\overline{\text{RESET}}$ . If the input is a logic low the EXTAL pin is configured for an external clock drive or a Pierce Oscillator. If input is a logic high a Colpitts oscillator circuit is configured on EXTAL and XTAL. Since this pin is an input with a pull-up device during reset, if the pin is left floating, the default configuration is a Colpitts oscillator circuit on EXTAL and XTAL.

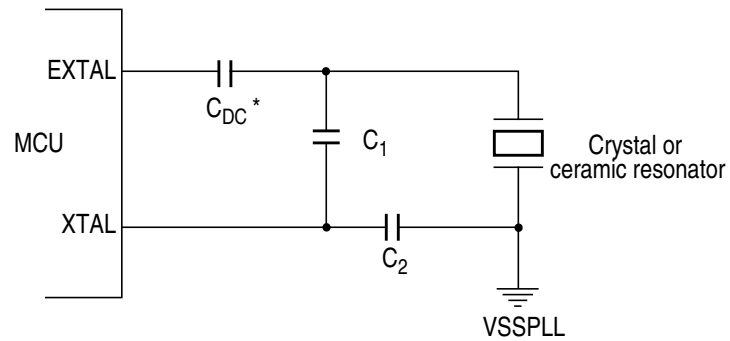
**Figure 2-4 Colpitts Oscillator Connections (PE7=1)**

- \* Due to the nature of a translated ground Colpitts oscillator a DC voltage bias is applied to the crystal  
 .Please contact the crystal manufacturer for crystal DC

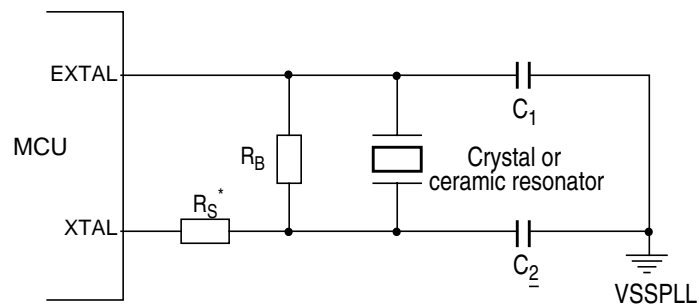
**Figure 2-5 Pierce Oscillator Connections (PE7=0)**

- \* R<sub>s</sub> can be zero (shorted) when use with higher frequency crystals.  
 Refer to manufacturer's data.

Figure 2-6 External Clock Connections (PE7=0)

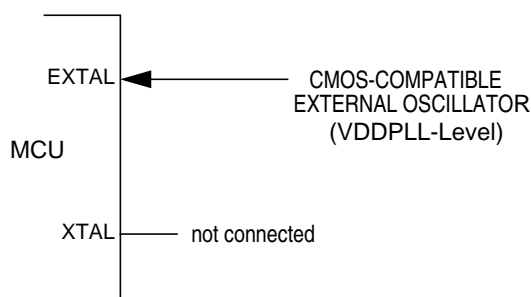

### 2.3.14 PE6 / MODB / IPIPE1 — Port E I/O Pin 6

PE6 is a general purpose input or output pin. It is used as a MCU operating mode select pin during reset. The state of this pin is latched to the MODB bit at the rising edge of  $\overline{\text{RESET}}$ . This pin is shared with the instruction queue tracking signal IPIPE1. This pin is an input with a pull-down device which is only active when  $\overline{\text{RESET}}$  is low.

### 2.3.15 PE5 / MODA / IPIPE0 — Port E I/O Pin 5

PE5 is a general purpose input or output pin. It is used as a MCU operating mode select pin during reset. The state of this pin is latched to the MODA bit at the rising edge of  $\overline{\text{RESET}}$ . This pin is shared with the instruction queue tracking signal IPIPE0. This pin is an input with a pull-down device which is only active when  $\overline{\text{RESET}}$  is low.

### 2.3.16 PE4 / ECLK — Port E I/O Pin 4

PE4 is a general purpose input or output pin. It can be configured to drive the internal bus clock ECLK. ECLK can be used as a timing reference.

### 2.3.17 PE3 / $\overline{\text{LSTRB}}$ / $\overline{\text{TAGLO}}$ — Port E I/O Pin 3

PE3 is a general purpose input or output pin. In MCU expanded modes of operation,  $\overline{\text{LSTRB}}$  can be used for the low-byte strobe function to indicate the type of bus access and when instruction tagging is on,  $\overline{\text{TAGLO}}$  is used to tag the low half of the instruction word being read into the instruction queue.

### 2.3.18 PE2 / $\overline{R\overline{W}}$ — Port E I/O Pin 2

PE2 is a general purpose input or output pin. In MCU expanded modes of operations, this pin drives the read/write output signal for the external bus. It indicates the direction of data on the external bus.

### 2.3.19 PE1 / $\overline{IRQ}$ — Port E Input Pin 1

PE1 is a general purpose input pin and the maskable interrupt request input that provides a means of applying asynchronous interrupt requests. This will wake up the MCU from STOP or WAIT mode.

### 2.3.20 PE0 / $\overline{XIRQ}$ — Port E Input Pin 0

PE0 is a general purpose input pin and the non-maskable interrupt request input that provides a means of applying asynchronous interrupt requests. This will wake up the MCU from STOP or WAIT mode.

### 2.3.21 PH7 / $\overline{KWH7}$ / $\overline{SS2}$ — Port H I/O Pin 7

PH7 is a general purpose input or output pin. It can be configured to generate an interrupt causing the MCU to exit STOP or WAIT mode. It can be configured as slave select pin  $\overline{SS}$  of the Serial Peripheral Interface 2 (SPI2).

### 2.3.22 PH6 / $\overline{KWH6}$ / SCK2 — Port H I/O Pin 6

PH6 is a general purpose input or output pin. It can be configured to generate an interrupt causing the MCU to exit STOP or WAIT mode. It can be configured as serial clock pin SCK of the Serial Peripheral Interface 2 (SPI2).

### 2.3.23 PH5 / $\overline{KWH5}$ / MOSI2 — Port H I/O Pin 5

PH5 is a general purpose input or output pin. It can be configured to generate an interrupt causing the MCU to exit STOP or WAIT mode. It can be configured as master output (during master mode) or slave input pin (during slave mode) MOSI of the Serial Peripheral Interface 2 (SPI2).

### 2.3.24 PH4 / $\overline{KWH4}$ / MISO2 — Port H I/O Pin 2

PH4 is a general purpose input or output pin. It can be configured to generate an interrupt causing the MCU to exit STOP or WAIT mode. It can be configured as master input (during master mode) or slave output (during slave mode) pin MISO of the Serial Peripheral Interface 2 (SPI2).

### 2.3.25 PH3 / $\overline{KWH3}$ / $\overline{SS1}$ — Port H I/O Pin 3

PH3 is a general purpose input or output pin. It can be configured to generate an interrupt causing the MCU to exit STOP or WAIT mode. It can be configured as slave select pin  $\overline{SS}$  of the Serial Peripheral Interface 1 (SPI1).

### 2.3.26 PH2 / KWH2 / SCK1 — Port H I/O Pin 2

PH2 is a general purpose input or output pin. It can be configured to generate an interrupt causing the MCU to exit STOP or WAIT mode. It can be configured as serial clock pin SCK of the Serial Peripheral Interface 1 (SPI1).

### 2.3.27 PH1 / KWH1 / MOSI1 — Port H I/O Pin 1

PH1 is a general purpose input or output pin. It can be configured to generate an interrupt causing the MCU to exit STOP or WAIT mode. It can be configured as master output (during master mode) or slave input pin (during slave mode) MOSI of the Serial Peripheral Interface 1 (SPI1).

### 2.3.28 PH0 / KWH0 / MISO1 — Port H I/O Pin 0

PH0 is a general purpose input or output pin. It can be configured to generate an interrupt causing the MCU to exit STOP or WAIT mode. It can be configured as master input (during master mode) or slave output (during slave mode) pin MISO of the Serial Peripheral Interface 1 (SPI1).

### 2.3.29 PJ7 / KWJ7 / TXCAN4 / SCL — PORT J I/O Pin 7

PJ7 is a general purpose input or output pin. It can be configured to generate an interrupt causing the MCU to exit STOP or WAIT mode. It can be configured as the transmit pin TXCAN for the Motorola Scalable Controller Area Network controller 4 (CAN4) or the serial clock pin SCL of the IIC module.

### 2.3.30 PJ6 / KWJ6 / RXCAN4 / SDA — PORT J I/O Pin 6

PJ6 is a general purpose input or output pin. It can be configured to generate an interrupt causing the MCU to exit STOP or WAIT mode. It can be configured as the receive pin RXCAN for the Motorola Scalable Controller Area Network controller 4 (CAN4) or the serial data pin SDA of the IIC module.

### 2.3.31 PJ[1:0] / KWJ[1:0] — Port J I/O Pins [1:0]

PJ1 and PJ0 are general purpose input or output pins. They can be configured to generate an interrupt causing the MCU to exit STOP or WAIT mode.

### 2.3.32 PK7 / $\overline{\text{ECS}}$ / ROMONE — Port K I/O Pin 7

PK7 is a general purpose input or output pin. During MCU expanded modes of operation, this pin is used as the emulation chip select output ( $\overline{\text{ECS}}$ ). During MCU normal expanded wide and narrow modes of operation, this pin is used to enable the Flash EEPROM memory in the memory map (ROMONE). At the rising edge of  $\overline{\text{RESET}}$ , the state of this pin is latched to the ROMON bit.

### 2.3.33 PK[5:0] / XADDR[19:14] — Port K I/O Pins [5:0]

PK5-PK0 are general purpose input or output pins. In MCU expanded modes of operation, these pins provide the expanded address XADDR[19:14] for the external bus.

### 2.3.34 PM7 / TXCAN4 — Port M I/O Pin 7

PM7 is a general purpose input or output pin. It can be configured as the transmit pin TXCAN of the Motorola Scalable Controller Area Network controller 4 (CAN4).

### 2.3.35 PM6 / RXCAN4 — Port M I/O Pin 6

PM6 is a general purpose input or output pin. It can be configured as the receive pin RXCAN of the Motorola Scalable Controller Area Network controller 4 (CAN4).

### 2.3.36 PM5 / TXCAN0 / TXCAN4 / SCK0 — Port M I/O Pin 5

PM5 is a general purpose input or output pin. It can be configured as the transmit pin TXCAN of the Motorola Scalable Controller Area Network controllers 0 or 4 (CAN0 or CAN4). It can be configured as the serial clock pin SCK of the Serial Peripheral Interface 0 (SPI0).

### 2.3.37 PM4 / RXCAN0 / RXCAN4/ MOSI0 — Port M I/O Pin 4

PM4 is a general purpose input or output pin. It can be configured as the receive pin RXCAN of the Motorola Scalable Controller Area Network controllers 0 or 4 (CAN0 or CAN4). It can be configured as the master output (during master mode) or slave input pin (during slave mode) MOSI for the Serial Peripheral Interface 0 (SPI0).

### 2.3.38 PM3 / TXCAN1 / TXCAN0 / $\overline{SS}$ 0 — Port M I/O Pin 3

PM3 is a general purpose input or output pin. It can be configured as the transmit pin TXCAN of the Motorola Scalable Controller Area Network controllers 1 or 0 (CAN1 or CAN0). It can be configured as the slave select pin  $\overline{SS}$  of the Serial Peripheral Interface 0 (SPI0).

### 2.3.39 PM2 / RXCAN1 / RXCAN0 / MISO0 — Port M I/O Pin 2

PM2 is a general purpose input or output pin. It can be configured as the receive pin RXCAN of the Motorola Scalable Controller Area Network controllers 1 or 0 (CAN1 or CAN0). It can be configured as the master input (during master mode) or slave output pin (during slave mode) MISO for the Serial Peripheral Interface 0 (SPI0).

### 2.3.40 PM1 / TXCAN0 / TXB — Port M I/O Pin 1

PM1 is a general purpose input or output pin. It can be configured as the transmit pin TXCAN of the Motorola Scalable Controller Area Network controller 0 (CAN0). It can be configured as the transmit pin TXB of the BDLC.

### 2.3.41 PM0 / RXCAN0 / RXB — Port M I/O Pin 0

PM0 is a general purpose input or output pin. It can be configured as the receive pin RXCAN of the Motorola Scalable Controller Area Network controller 0 (CAN0). It can be configured as the receive pin RXB of the BDLC.

### 2.3.42 PP7 / KWP7 / PWM7 / SCK2 — Port P I/O Pin 7

PP7 is a general purpose input or output pin. It can be configured to generate an interrupt causing the MCU to exit STOP or WAIT mode. It can be configured as Pulse Width Modulator (PWM) channel 7 output. It can be configured as serial clock pin SCK of the Serial Peripheral Interface 2 (SPI2).

### 2.3.43 PP6 / KWP6 / PWM6 / $\overline{SS2}$ — Port P I/O Pin 6

PP6 is a general purpose input or output pin. It can be configured to generate an interrupt causing the MCU to exit STOP or WAIT mode. It can be configured as Pulse Width Modulator (PWM) channel 6 output. It can be configured as slave select pin  $\overline{SS}$  of the Serial Peripheral Interface 2 (SPI2).

### 2.3.44 PP5 / KWP5 / PWM5 / MOSI2 — Port P I/O Pin 5

PP5 is a general purpose input or output pin. It can be configured to generate an interrupt causing the MCU to exit STOP or WAIT mode. It can be configured as Pulse Width Modulator (PWM) channel 5 output. It can be configured as master output (during master mode) or slave input pin (during slave mode) MOSI of the Serial Peripheral Interface 2 (SPI2).

### 2.3.45 PP4 / KWP4 / PWM4 / MISO2 — Port P I/O Pin 4

PP4 is a general purpose input or output pin. It can be configured to generate an interrupt causing the MCU to exit STOP or WAIT mode. It can be configured as Pulse Width Modulator (PWM) channel 4 output. It can be configured as master input (during master mode) or slave output (during slave mode) pin MISO of the Serial Peripheral Interface 2 (SPI2).

### 2.3.46 PP3 / KWP3 / PWM3 / $\overline{SS1}$ — Port P I/O Pin 3

PP3 is a general purpose input or output pin. It can be configured to generate an interrupt causing the MCU to exit STOP or WAIT mode. It can be configured as Pulse Width Modulator (PWM) channel 3 output. It can be configured as slave select pin  $\overline{SS}$  of the Serial Peripheral Interface 1 (SPI1).



### 2.3.47 PP2 / KWP2 / PWM2 / SCK1 — Port P I/O Pin 2

PP2 is a general purpose input or output pin. It can be configured to generate an interrupt causing the MCU to exit STOP or WAIT mode. It can be configured as Pulse Width Modulator (PWM) channel 2 output. It can be configured as serial clock pin SCK of the Serial Peripheral Interface 1 (SPI1).

### 2.3.48 PP1 / KWP1 / PWM1 / MOSI1 — Port P I/O Pin 1

PP1 is a general purpose input or output pin. It can be configured to generate an interrupt causing the MCU to exit STOP or WAIT mode. It can be configured as Pulse Width Modulator (PWM) channel 1 output. It can be configured as master output (during master mode) or slave input pin (during slave mode) MOSI of the Serial Peripheral Interface 1 (SPI1).

### 2.3.49 PP0 / KWP0 / PWM0 / MISO1 — Port P I/O Pin 0

PP0 is a general purpose input or output pin. It can be configured to generate an interrupt causing the MCU to exit STOP or WAIT mode. It can be configured as Pulse Width Modulator (PWM) channel 0 output. It can be configured as master input (during master mode) or slave output (during slave mode) pin MISO of the Serial Peripheral Interface 1 (SPI1).

### 2.3.50 PS7 / $\overline{SS0}$ — Port S I/O Pin 7

PS6 is a general purpose input or output pin. It can be configured as the slave select pin  $\overline{SS}$  of the Serial Peripheral Interface 0 (SPI0).

### 2.3.51 PS6 / SCK0 — Port S I/O Pin 6

PS6 is a general purpose input or output pin. It can be configured as the serial clock pin SCK of the Serial Peripheral Interface 0 (SPI0).

### 2.3.52 PS5 / MOSI0 — Port S I/O Pin 5

PS5 is a general purpose input or output pin. It can be configured as master output (during master mode) or slave input pin (during slave mode) MOSI of the Serial Peripheral Interface 0 (SPI0).

### 2.3.53 PS4 / MISO0 — Port S I/O Pin 4

PS4 is a general purpose input or output pin. It can be configured as master input (during master mode) or slave output pin (during slave mode) MOSI of the Serial Peripheral Interface 0 (SPI0).

### 2.3.54 PS3 / TXD1 — Port S I/O Pin 3

PS3 is a general purpose input or output pin. It can be configured as the transmit pin TXD of Serial Communication Interface 1 (SCI1).

### 2.3.55 PS2 / RXD1 — Port S I/O Pin 2

PS2 is a general purpose input or output pin. It can be configured as the receive pin RXD of Serial Communication Interface 1 (SCI1).

### 2.3.56 PS1 / TXD0 — Port S I/O Pin 1

PS1 is a general purpose input or output pin. It can be configured as the transmit pin TXD of Serial Communication Interface 0 (SCI0).

### 2.3.57 PS0 / RXD0 — Port S I/O Pin 0

PS0 is a general purpose input or output pin. It can be configured as the receive pin RXD of Serial Communication Interface 0 (SCI0).

### 2.3.58 PT[7:0] / IOC[7:0] — Port T I/O Pins [7:0]

PT7-PT0 are general purpose input or output pins. They can be configured as input capture or output compare pins IOC7-IOC0 of the Enhanced Capture Timer (ECT).

## 2.4 Power Supply Pins

MC9S12DT256 power and ground pins are described below.

**NOTE:** *All VSS pins must be connected together in the application.*

### 2.4.1 VDDX,VSSX — Power & Ground Pins for I/O Drivers

External power and ground for I/O drivers. Because fast signal transitions place high, short-duration current demands on the power supply, use bypass capacitors with high-frequency characteristics and place them as close to the MCU as possible. Bypass requirements depend on how heavily the MCU pins are loaded.

### 2.4.2 VDDR, VSSR — Power & Ground Pins for I/O Drivers & for Internal Voltage Regulator

External power and ground for I/O drivers and input to the internal voltage regulator. Because fast signal transitions place high, short-duration current demands on the power supply, use bypass capacitors with high-frequency characteristics and place them as close to the MCU as possible. Bypass requirements depend on how heavily the MCU pins are loaded.

### 2.4.3 VDD1, VDD2, VSS1, VSS2 — Core Power Pins

Power is supplied to the MCU through VDD and VSS. Because fast signal transitions place high, short-duration current demands on the power supply, use bypass capacitors with high-frequency characteristics and place them as close to the MCU as possible. This 2.5V supply is derived from the internal voltage regulator. There is no static load on those pins allowed. The internal voltage regulator is turned off, if VREGEN is tied to ground.

**NOTE:** *No load allowed except for bypass capacitors.*

### 2.4.4 VDDA, VSSA — Power Supply Pins for ATD and VREG

VDDA, VSSA are the power supply and ground input pins for the voltage regulator and the analog to digital converter. It also provides the reference for the internal voltage regulator. This allows the supply voltage to the ATD and the reference voltage to be bypassed independently.

### 2.4.5 VRH, VRL — ATD Reference Voltage Input Pins

VRH and VRL are the reference voltage input pins for the analog to digital converter.

### 2.4.6 VDDPLL, VSSPLL — Power Supply Pins for PLL

Provides operating voltage and ground for the Oscillator and the Phased-Locked Loop. This allows the supply voltage to the Oscillator and PLL to be bypassed independently. This 2.5V voltage is generated by the internal voltage regulator.

**NOTE:** *No load allowed except for bypass capacitors.*

**Table 2-2 MC9S12DP256 Power and Ground Connection Summary**

Mnemonic	Pin Number	Nominal Voltage	Description
	112-pin QFP		
V <sub>DD1,2</sub>	13, 65	2.5 V	Internal power and ground generated by internal regulator
V <sub>SS1,2</sub>	14, 66	0V	
V <sub>DDR</sub>	41	5.0 V	External power and ground, supply to pin drivers and internal voltage regulator.
V <sub>SSR</sub>	40	0 V	
V <sub>DDX</sub>	107	5.0 V	External power and ground, supply to pin drivers.
V <sub>SSX</sub>	106	0 V	
V <sub>DDA</sub>	83	5.0 V	Operating voltage and ground for the analog-to-digital converters and the reference for the internal voltage regulator, allows the supply voltage to the A/D to be bypassed independently.
V <sub>SSA</sub>	86	0 V	
V <sub>RL</sub>	85	0 V	Reference voltages for the analog-to-digital converter.
V <sub>RH</sub>	84	5.0 V	

Mnemonic	Pin Number	Nominal Voltage	Description
	112-pin QFP		
V <sub>DDPLL</sub>	43	2.5 V	Provides operating voltage and ground for the Phased-Locked Loop. This allows the supply voltage to the PLL to be bypassed independently. Internal power and ground generated by internal regulator.
V <sub>SSPLL</sub>	45	0 V	
VREGEN	97	5V	Internal Voltage Regulator enable/disable

## 2.4.7 VREGEN — On Chip Voltage Regulator Enable

Enables the internal 5V to 2.5V voltage regulator. If this pin is tied low, VDD1,2 and VDDPLL must be supplied externally.

## Section 3 System Clock Description

### 3.1 Overview

The Clock and Reset Generator provides the internal clock signals for the core and all peripheral modules.

**Figure 3-1** shows the clock connections from the CRG to all modules.

Consult the CRG Block User Guide for details on clock generation.

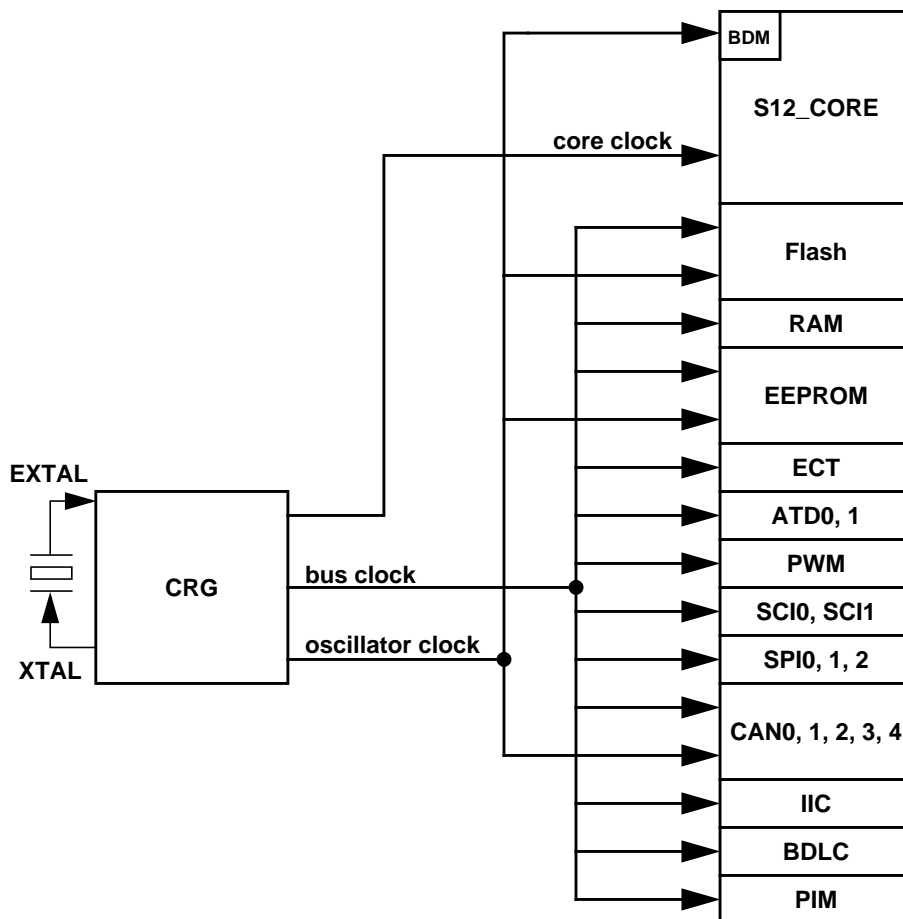

Figure 3-1 Clock Connections



## Section 4 Modes of Operation

### 4.1 Overview

Eight possible modes determine the operating configuration of the MC9S12DT256. Each mode has an associated default memory map and external bus configuration controlled by a further pin.

Three low power modes exist for the device.

### 4.2 Chip Configuration Summary

The operating mode out of reset is determined by the states of the MODC, MODB, and MODA pins during reset (**Table 4-1**). The MODC, MODB, and MODA bits in the MODE register show the current operating mode and provide limited mode switching during operation. The states of the MODC, MODB, and MODA pins are latched into these bits on the rising edge of the reset signal. The ROMCTL signal allows the setting of the ROMON bit in the MISC register thus controlling whether the internal Flash is visible in the memory map. ROMON = 1 mean the Flash is visible in the memory map. The state of the ROMCTL pin is latched into the ROMON bit in the MISC register on the rising edge of the reset signal.

**Table 4-1 Mode Selection**

BKGD = MODC	PE6 = MODB	PE5 = MODA	PK7 = ROMCTL	ROMON Bit	Mode Description
0	0	0	X	1	Special Single Chip, BDM allowed and ACTIVE. BDM is allowed in all other modes but a serial command is required to make BDM active.
0	0	1	0	1	Emulation Expanded Narrow, BDM allowed
			1	0	
0	1	0	X	0	Special Test (Expanded Wide), BDM allowed
0	1	1	0	1	Emulation Expanded Wide, BDM allowed
			1	0	
1	0	0	X	1	Normal Single Chip, BDM allowed
1	0	1	0	0	Normal Expanded Narrow, BDM allowed
			1	1	
1	1	0	X	1	Peripheral; BDM allowed but bus operations would cause bus conflicts (must not be used)
1	1	1	0	0	Normal Expanded Wide, BDM allowed
			1	1	

For further explanation on the modes refer to the Core User Guide.

**Table 4-2 Clock Selection Based on PE7**

PE7 = $\overline{XCLKS}$	Description
1	Colpitts Oscillator selected

**Table 4-2 Clock Selection Based on PE7**

PE7 = XCLKS	Description
0	Pierce Oscillator/external clock selected

**Table 4-3 Voltage Regulator VREGEN**

VREGEN	Description
1	Internal Voltage Regulator enabled
0	Internal Voltage Regulator disabled, VDD1,2 and VDDPLL must be supplied externally with 2.5V

## 4.3 Security

The device will make available a security feature preventing the unauthorized read and write of the memory contents. This feature allows:

- Protection of the contents of FLASH,
- Protection of the contents of EEPROM,
- Operation in single-chip mode,
- Operation from external memory with internal FLASH and EEPROM disabled.

The user must be reminded that part of the security must lie with the user's code. An extreme example would be user's code that dumps the contents of the internal program. This code would defeat the purpose of security. At the same time the user may also wish to put a back door in the user's program. An example of this is the user downloads a key through the SCI which allows access to a programming routine that updates parameters stored in EEPROM.

### 4.3.1 Securing the Microcontroller

Once the user has programmed the FLASH and EEPROM (if desired), the part can be secured by programming the security bits located in the FLASH module. These non-volatile bits will keep the part secured through resetting the part and through powering down the part.

The security byte resides in a portion of the Flash array.

Check the Flash Block User Guide for more details on the security configuration.

### 4.3.2 Operation of the Secured Microcontroller

#### 4.3.2.1 Normal Single Chip Mode

This will be the most common usage of the secured part. Everything will appear the same as if the part was not secured with the exception of BDM operation. The BDM operation will be blocked.



### 4.3.2.2 Executing from External Memory

The user may wish to execute from external space with a secured microcontroller. This is accomplished by resetting directly into expanded mode. The internal FLASH and EEPROM will be disabled. BDM operations will be blocked.

### 4.3.3 Unsecuring the Microcontroller

In order to unsecure the microcontroller, the internal FLASH and EEPROM must be erased. This can be done through an external program in expanded mode.

Once the user has erased the FLASH and EEPROM, the part can be reset into special single chip mode. This invokes a program that verifies the erasure of the internal FLASH and EEPROM. Once this program completes, the user can erase and program the FLASH security bits to the unsecured state. This is generally done through the BDM, but the user could also change to expanded mode (by writing the mode bits through the BDM) and jumping to an external program (again through BDM commands). Note that if the part goes through a reset before the security bits are reprogrammed to the unsecure state, the part will be secured again.

## 4.4 Low Power Modes

The microcontroller features three main low power modes. Consult the respective Block User Guide for information on the module behavior in Stop, Pseudo Stop, and Wait Mode. An important source of information about the clock system is the Clock and Reset Generator User Guide (CRG).

### 4.4.1 Stop

Executing the CPU STOP instruction stops all clocks and the oscillator thus putting the chip in fully static mode. Wake up from this mode can be done via reset or external interrupts.

### 4.4.2 Pseudo Stop

This mode is entered by executing the CPU STOP instruction. In this mode the oscillator is still running and the Real Time Interrupt (RTI) or Watchdog (COP) sub module can stay active. Other peripherals are turned off. This mode consumes more current than the full STOP mode, but the wake up time from this mode is significantly shorter.

### 4.4.3 Wait

This mode is entered by executing the CPU WAI instruction. In this mode the CPU will not execute instructions. The internal CPU signals (address and databus) will be fully static. All peripherals stay active. For further power consumption the peripherals can individually turn off their local clocks.

## 4.4.4 Run

Although this is not a low power mode, unused peripheral modules should not be enabled in order to save power.

## Section 5 Resets and Interrupts

### 5.1 Overview

Consult the Exception Processing section of the HCS12 Core User Guide for information on resets and interrupts.

### 5.2 Vectors

#### 5.2.1 Vector Table

**Table 5-1** lists interrupt sources and vectors in default order of priority.

**Table 5-1 Interrupt Vector Locations**

Vector Address	Interrupt Source	CCR Mask	Local Enable	HPRIO Value to Elevate
\$FFFE, \$FFFF	Reset	None	None	–
\$FFFC, \$FFFD	Clock Monitor fail reset	None	PLLCTL (CME, SCME)	–
\$FFFA, \$FFFB	COP failure reset	None	COP rate select	–
\$FFF8, \$FFF9	Unimplemented instruction trap	None	None	–
\$FFF6, \$FFF7	SWI	None	None	–
\$FFF4, \$FFF5	XIRQ	X-Bit	None	–
\$FFF2, \$FFF3	IRQ	I-Bit	IRQCR (IRQEN)	\$F2
\$FFF0, \$FFF1	Real Time Interrupt	I-Bit	CRGINT (RTIE)	\$F0
\$FFEE, \$FFEF	Enhanced Capture Timer channel 0	I-Bit	TIE (C0I)	\$EE
\$FFEC, \$FFED	Enhanced Capture Timer channel 1	I-Bit	TIE (C1I)	\$EC
\$FFEA, \$FFEB	Enhanced Capture Timer channel 2	I-Bit	TIE (C2I)	\$EA
\$FFE8, \$FFE9	Enhanced Capture Timer channel 3	I-Bit	TIE (C3I)	\$E8
\$FFE6, \$FFE7	Enhanced Capture Timer channel 4	I-Bit	TIE (C4I)	\$E6
\$FFE4, \$FFE5	Enhanced Capture Timer channel 5	I-Bit	TIE (C5I)	\$E4
\$FFE2, \$FFE3	Enhanced Capture Timer channel 6	I-Bit	TIE (C6I)	\$E2
\$FFE0, \$FFE1	Enhanced Capture Timer channel 7	I-Bit	TIE (C7I)	\$E0
\$FFDE, \$FFDF	Enhanced Capture Timer overflow	I-Bit	TSRC2 (TOF)	\$DE
\$FFDC, \$FFDD	Pulse accumulator A overflow	I-Bit	PACTL (PAOVI)	\$DC
\$FFDA, \$FFDB	Pulse accumulator input edge	I-Bit	PACTL (PAI)	\$DA
\$FFD8, \$FFD9	SPI0	I-Bit	SP0CR1 (SPIE, SPTIE)	\$D8
\$FFD6, \$FFD7	SCI0	I-Bit	SC0CR2 (TIE, TCIE, RIE, ILIE)	\$D6
\$FFD4, \$FFD5	SCI1	I-Bit	SC1CR2 (TIE, TCIE, RIE, ILIE)	\$D4
\$FFD2, \$FFD3	ATD0	I-Bit	ATD0CTL2 (ASCIE)	\$D2

\$FFD0, \$FFD1	ATD1	I-Bit	ATD1CTL2 (ASCIE)	\$D0
\$FFCE, \$FFCF	Port J	I-Bit	PTJIF (PTJIE)	\$CE
\$FFCC, \$FFCD	Port H	I-Bit	PTHIF(PTHIE)	\$CC
\$FFCA, \$FFCB	Modulus Down Counter underflow	I-Bit	MCCTL(MCZI)	\$CA
\$FFC8, \$FFC9	Pulse Accumulator B Overflow	I-Bit	PBCTL(PBOVI)	\$C8
\$FFC6, \$FFC7	CRG PLL lock	I-Bit	CRGINT(LOCKIE)	\$C6
\$FFC4, \$FFC5	CRG Self Clock Mode	I-Bit	CRGINT (SCMIE)	\$C4
\$FFC2, \$FFC3	BDLC	I-Bit	DLCBCR1(IE)	\$C2
\$FFC0, \$FFC1	IIC Bus	I-Bit	IBCR (IBIE)	\$C0
\$FFBE, \$FFBF	SPI1	I-Bit	SP1CR1 (SPIE, SPTIE)	\$BE
\$FFBC, \$FFBD	SPI2	I-Bit	SP2CR1 (SPIE, SPTIE)	\$BC
\$FFBA, \$FFBB	EEPROM	I-Bit	ECNFG (CCIE, CBEIE)	\$BA
\$FFB8, \$FFB9	FLASH	I-Bit	FCNFG (CCIE, CBEIE)	\$B8
\$FFB6, \$FFB7	CAN0 wake-up	I-Bit	CAN0RIER (WUPIE)	\$B6
\$FFB4, \$FFB5	CAN0 errors	I-Bit	CAN0RIER (CSCIE, OVRIE)	\$B4
\$FFB2, \$FFB3	CAN0 receive	I-Bit	CAN0RIER (RXFIE)	\$B2
\$FFB0, \$FFB1	CAN0 transmit	I-Bit	CAN0TIER (TXEIE2-TXEIE0)	\$B0
\$FFAE, \$FFAF	CAN1 wake-up	I-Bit	CAN1RIER (WUPIE)	\$AE
\$FFAC, \$FFAD	CAN1 errors	I-Bit	CAN1RIER (CSCIE, OVRIE)	\$AC
\$FFAA, \$FFAB	CAN1 receive	I-Bit	CAN1RIER (RXFIE)	\$AA
\$FFA8, \$FFA9	CAN1 transmit	I-Bit	CAN1TIER (TXEIE2-TXEIE0)	\$A8
\$FFA6, \$FFA7	Reserved			
\$FFA4, \$FFA5				
\$FFA2, \$FFA3				
\$FFA0, \$FFA1				
\$FF9E, \$FF9F				
\$FF9C, \$FF9D				
\$FF9A, \$FF9B				
\$FF98, \$FF99				
\$FF96, \$FF97				
\$FF94, \$FF95	CAN4 errors	I-Bit	CAN4RIER (CSCIE, OVRIE)	\$94
\$FF92, \$FF93	CAN4 receive	I-Bit	CAN4RIER (RXFIE)	\$92
\$FF90, \$FF91	CAN4 transmit	I-Bit	CAN4TIER (TXEIE2-TXEIE0)	\$90
\$FF8E, \$FF8F	Port P Interrupt	I-Bit	PTPIF (PTPIE)	\$8E
\$FF8C, \$FF8D	PWM Emergency Shutdown	I-Bit	PWMSDN (PWMIE)	\$8C
\$FF80 to \$FF8B	Reserved			

## 5.3 Effects of Reset

When a reset occurs, MCU registers and control bits are changed to known start-up states. Refer to the respective module Block User Guides for register reset states.

### 5.3.1 I/O pins

Refer to the HCS12 Core User Guides for mode dependent pin configuration of port A, B, E and K out of reset.

Refer to the PIM Block User Guide for reset configurations of all peripheral module ports.

**NOTE:** *For devices assembled in 80-pin QFP packages all non-bonded out pins should be configured as outputs after reset in order to avoid current drawn from floating inputs. Refer to **Table 2-1** for affected pins.*

### 5.3.2 Memory

Refer to **Table 1-1** for locations of the memories depending on the operating mode after reset.

The RAM array is not automatically initialized out of reset.



## Section 6 HCS12 Core Block Description

### 6.1 CPU12 Block Description

Consult the CPU12 Reference Manual for information on the CPU.

When the CPU12 Reference Manual refers to *cycles* this is equivalent to *Bus Clock Periods*.

### 6.2 HCS12 Module Mapping Control (MMC) Block Description

Consult the MMC Block User Guide for information on the Module Mapping Control Block.

#### 6.2.1 Device specific information

- INITEE
  - Reset state: \$01
  - Bits EE11-EE15 are writeable once in Normal and Emulation Mode
- PPAGE
  - Reset state : \$00
  - Register is writeable anytime in all modes

### 6.3 HCS12 Multiplexed External Bus Interface (MEBI) Block Description

Consult the MEBI Block Guide for information on Multiplexed External Bus Interface.

#### 6.3.1 Device specific information

- PUCR
  - Reset State : \$90

### 6.4 HCS12 Interrupt (INT) Block description

Consult the INT Block guide for information on HCS12 Interrupt block.

### 6.5 HCS12 Background Debug (BDM) Block Description

Consult the BDM Block guide for information on HCS12 Background Debug block

## 6.6 HCS12 Breakpoint (BKP) Block Description

Consult the BKP Block guide for information on HCS12 breakpoint block

## Section 7 Clock and Reset Generator (CRG) Block Description

Consult the CRG Block User Guide for information about the Clock and Reset Generator module.

### 7.1 Device-specific information

#### 7.1.1 $\overline{\text{XCLKS}}$

The  $\overline{\text{XCLKS}}$  input signal is active low (see 2.3.13 PE7 / NOACC / XCLKS — Port E I/O Pin 7).

## Section 8 Enhanced Capture Timer (ECT) Block Description

Consult the ECT\_16B8C Block User Guide for information about the Enhanced Capture Timer module. When the ECT\_16B8C Block Guide refers to freeze mode this is equivalent to active BDM mode.

## Section 9 Analog to Digital Converter (ATD) Block Description

There are two Analog to Digital Converters (ATD1 and ATD0) implemented on the MC9S12DT256. Consult the ATD\_10B8C Block User Guide for information about each Analog to Digital Converter module. When the ATD\_10B8C Block Guide refers to freeze mode this is equivalent to active BDM mode.

## Section 10 Inter-IC Bus (IIC) Block Description

Consult the IIC Block User Guide for information about the Inter-IC Bus module.

## Section 11 Serial Communications Interface (SCI) Block Description



There are two Serial Communications Interfaces (SCI1 and SCI0) implemented on the MC9S12DT256 device. Consult the SCI Block User Guide for information about each Serial Communications Interface module.

## Section 12 Serial Peripheral Interface (SPI) Block Description

There are three Serial Peripheral Interfaces(SPI2, SPI1 and SPI0) implemented on MC9S12DT256. Consult the SPI Block User Guide for information about each Serial Peripheral Interface module.

## Section 13 J1850 (BDLC) Block Description

Consult the BDLC Block User Guide for information about the J1850 module.

## Section 14 Pulse Width Modulator (PWM) Block Description

Consult the PWM\_8B8C Block User Guide for information about the Pulse Width Modulator module. When the PWM\_8B8C Block Guide refers to freeze mode this is equivalent to active BDM mode

## Section 15 Flash EEPROM 256K Block Description

The "S12 LRAE" is a generic Load RAM and Execute (LRAE) program which will be programmed into the flash memory of this device during manufacture. This LRAE program will provide greater programming flexibility to the end users by allowing the device to be programmed directly using CAN or SCI after it is assembled on the PCB. Use of the LRAE program is at the discretion of the end user and, if not required, it must simply be erased prior to flash programming. For more details of the S12 LRAE and its implementation, please see the S12 LREA Application Note (AN2546/D).

It is planned that most HC9S12 devices manufactured after Q1 of 2004 will be shipped with the S12 LRAE programmed in the Flash. Exact details of the changeover (i.e. blank to programmed) for each product will be communicated in advance via GPCN and will be traceable by the customer via datecode marking on the device.

Please contact Motorola SPS Sales if you have any additional questions.

Consult the FTS256K Block User Guide for information about the flash module.

## Section 16 EEPROM 4K Block Description

Consult the EETS4K Block User Guide for information about the EEPROM module.

## **Section 17 RAM Block Description**

This module supports single-cycle misaligned word accesses.

## **Section 18 MSCAN Block Description**

There are three MSCAN modules (CAN4, CAN1 and CAN0) implemented on the MC9S12DT256. Consult the MSCAN Block User Guide for information about the Motorola Scalable CAN Module.

## **Section 19 Port Integration Module (PIM) Block Description**

Consult the PIM\_9DP256 Block User Guide for information about the Port Integration Module.

## **Section 20 Voltage Regulator (VREG) Block Description**

Consult the VREG Block User Guide for information about the dual output linear voltage regulator.

Component	Purpose	Type	Value
C1	VDD1 filter cap	ceramic X7R	100 .. 220nF
C2	VDD2 filter cap	ceramic X7R	100 .. 220nF
C3	VDDA filter cap	ceramic X7R	100nF
C4	VDDR filter cap	X7R/tantalum	>=100nF
C5	VDDPLL filter cap	ceramic X7R	100nF
C6	VDDX filter cap	X7R/tantalum	>=100nF
C7	OSC load cap		
C8	OSC load cap		
C9 / C <sub>S</sub>	PLL loop filter cap	See PLL specification chapter	
C10 / C <sub>P</sub>	PLL loop filter cap		
C11 / C <sub>DC</sub>	DC cutoff cap	Colpitts mode only, if recommended by quartz manufacturer	
R1 / R	PLL loop filter res	See PLL Specification chapter	
R2 / R <sub>B</sub>		Pierce mode only	
R3 / R <sub>S</sub>			
Q1	Quartz		

The PCB must be carefully laid out to ensure proper operation of the voltage regulator as well as of the MCU itself. The following rules must be observed:

- Every supply pair must be decoupled by a ceramic capacitor connected as near as possible to the corresponding pins (C1 – C6).
- Central point of the ground star should be the VSSR pin.
- Use low ohmic low inductance connections between VSS1, VSS2 and VSSR.
- VSSPLL must be directly connected to VSSR.
- Keep traces of VSSPLL, EXTAL and XTAL as short as possible and occupied board area for C7, C8, C11 and Q1 as small as possible.
- Do not place other signals or supplies underneath area occupied by C7, C8, C10 and Q1 and the connection area to the MCU.
- Central power input should be fed in at the VDDA/VSSA pins.

Figure 20-1 Recommended PCB Layout for 112LQFP Colpitts Oscillator

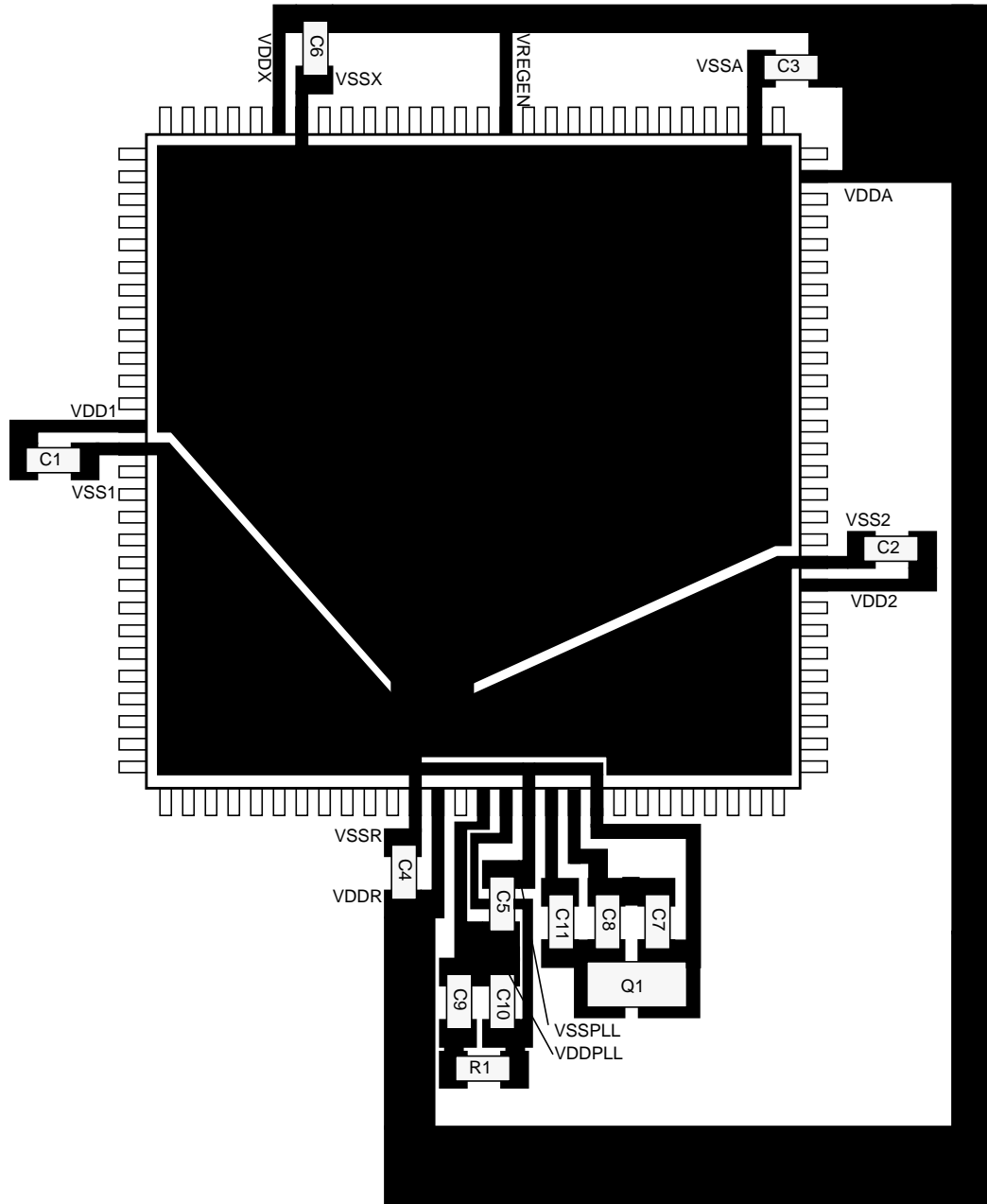

Figure 20-2 Recommended PCB Layout for 80QFP Colpitts Oscillator

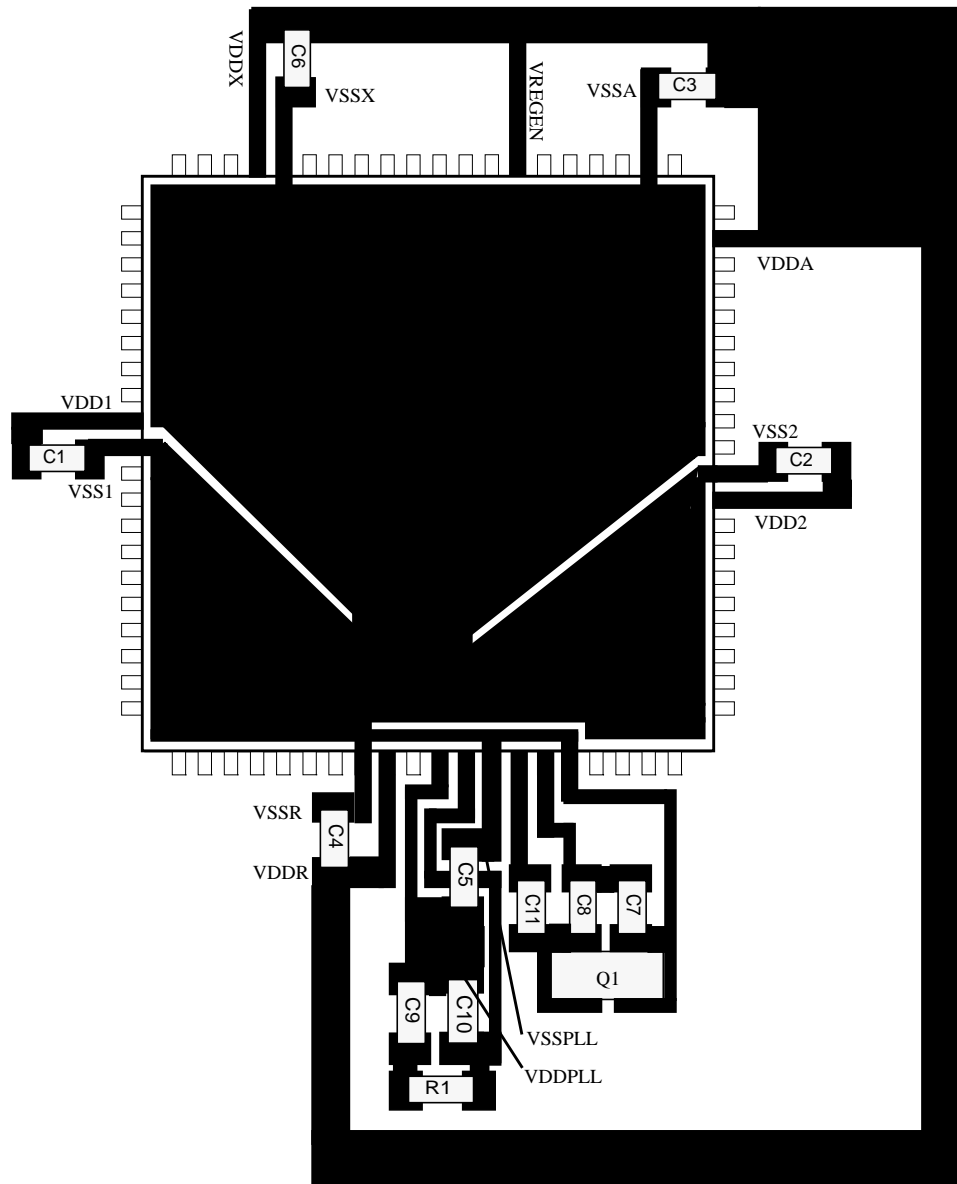

Figure 20-3 Recommended PCB Layout for 112LQFP Pierce Oscillator

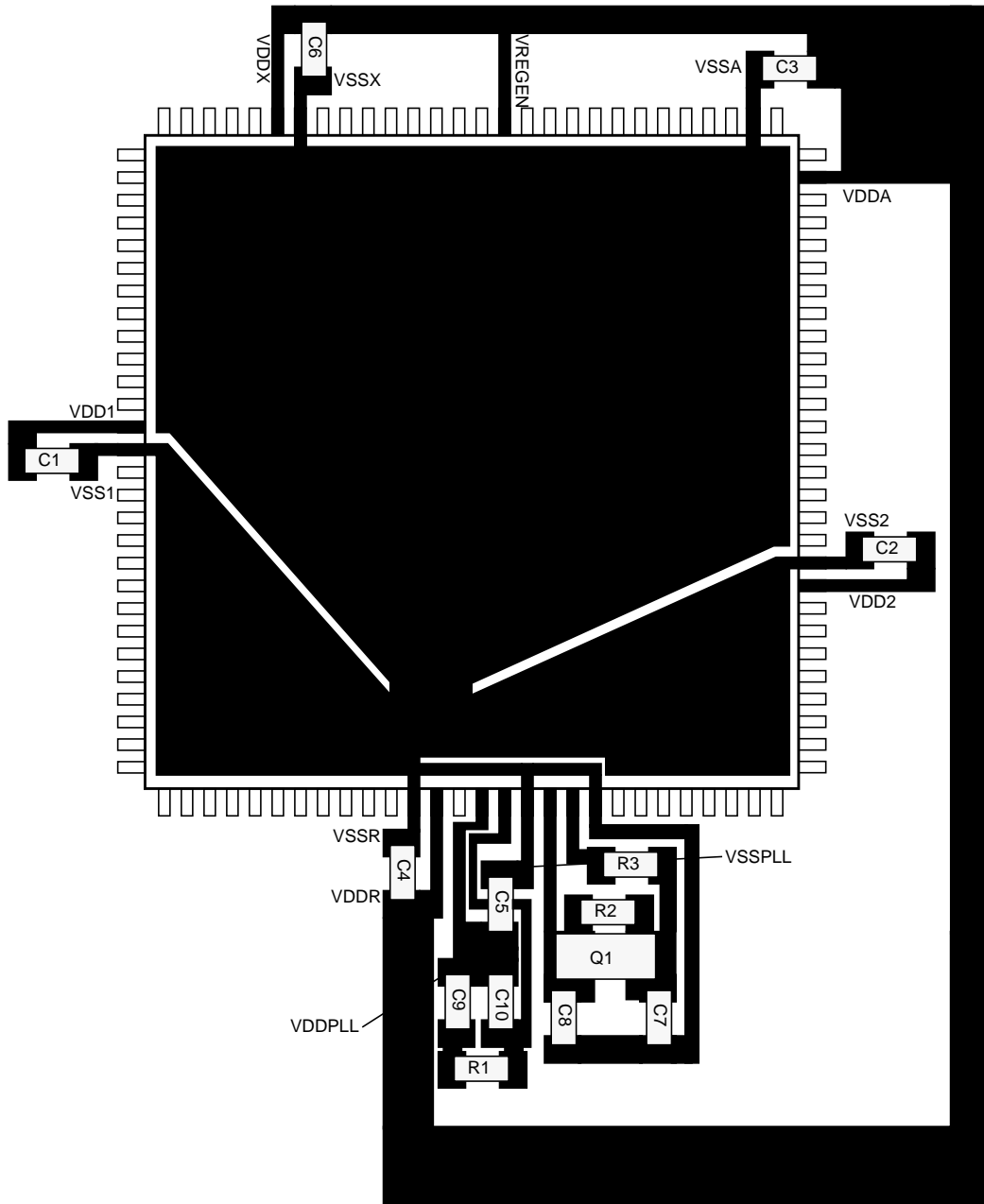
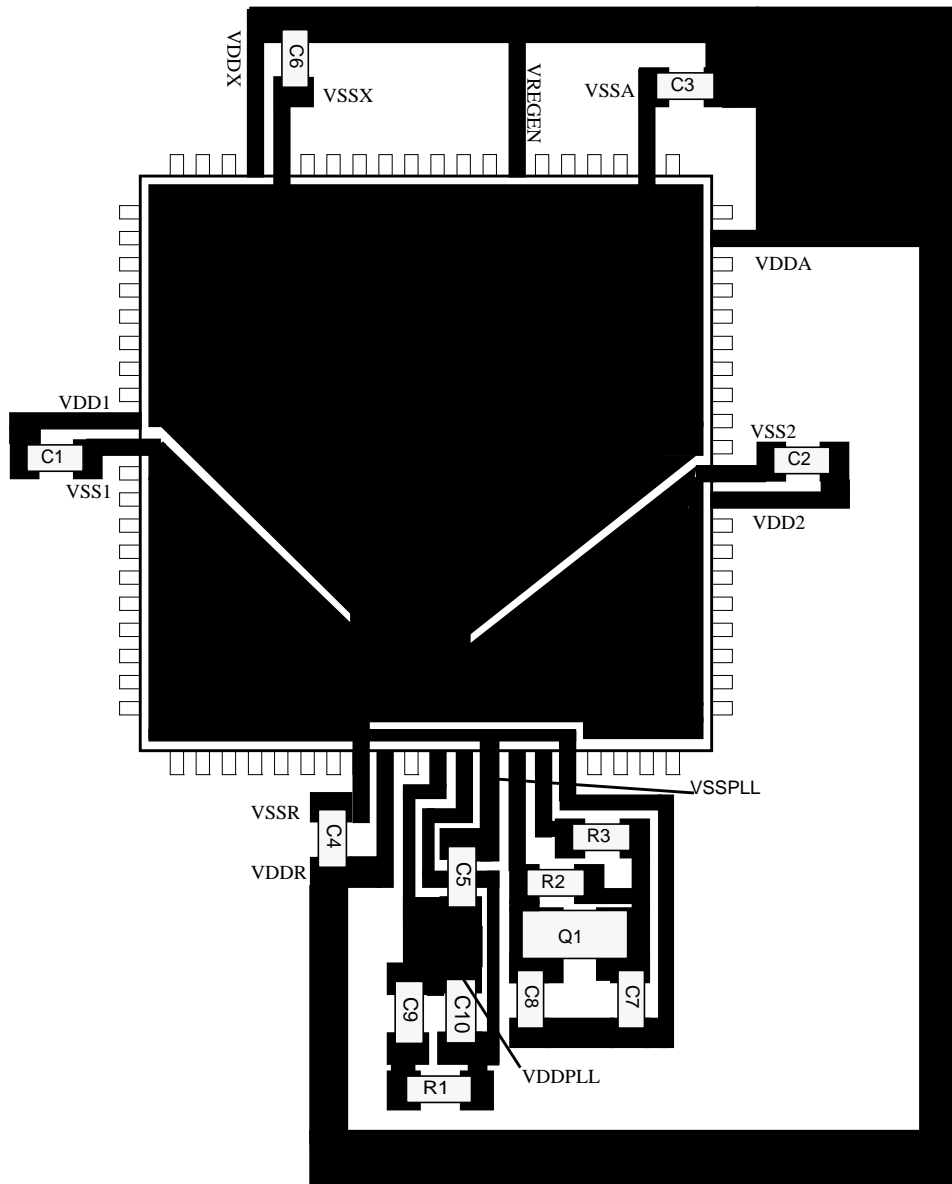

Figure 20-4 Recommended PCB Layout for 80QFP Pierce Oscillator







# Appendix A Electrical Characteristics

## A.1 General

**NOTE:** *The electrical characteristics given in this section are preliminary and should be used as a guide only. Values cannot be guaranteed by Motorola and are subject to change without notice.*

This supplement contains the most accurate electrical information for the MC9S12DT256 microcontroller available at the time of publication. The information should be considered **PRELIMINARY** and is subject to change.

This introduction is intended to give an overview on several common topics like power supply, current injection etc.

### A.1.1 Parameter Classification

The electrical parameters shown in this supplement are guaranteed by various methods. To give the customer a better understanding the following classification is used and the parameters are tagged accordingly in the tables where appropriate.

**NOTE:** *This classification is shown in the column labeled “C” in the parameter tables where appropriate.*

P:

Those parameters are guaranteed during production testing on each individual device.

C:

Those parameters are achieved by the design characterization by measuring a statistically relevant sample size across process variations.

T:

Those parameters are achieved by design characterization on a small sample size from typical devices under typical conditions unless otherwise noted. All values shown in the typical column are within this category.

D:

Those parameters are derived mainly from simulations.

### A.1.2 Power Supply

The MC9S12DT256 utilizes several pins to supply power to the I/O ports, A/D converter, oscillator and PLL as well as the digital core.

The VDDA, VSSA pair supplies the A/D converter and the resistor ladder of the internal voltage regulator.

The VDDX, VSSX, VDDR and VSSR pairs supply the I/O pins, VDDR supplies also the internal voltage regulator.

VDD1, VSS1, VDD2 and VSS2 are the supply pins for the digital logic, VDDPLL, VSSPLL supply the oscillator and the PLL.

VSS1 and VSS2 are internally connected by metal.

VDDA, VDDX, VDDR as well as VSSA, VSSX, VSSR are connected by anti-parallel diodes for ESD protection.

**NOTE:** *In the following context VDD5 is used for either VDDA, VDDR and VDDX; VSS5 is used for either VSSA, VSSR and VSSX unless otherwise noted. IDD5 denotes the sum of the currents flowing into the VDDA, VDDX and VDDR pins. VDD is used for VDD1, VDD2 and VDDPLL, VSS is used for VSS1, VSS2 and VSSPLL. IDD is used for the sum of the currents flowing into VDD1 and VDD2.*

### A.1.3 Pins

There are four groups of functional pins.

#### A.1.3.1 5V I/O pins

Those I/O pins have a nominal level of 5V. This class of pins is comprised of all port I/O pins, the analog inputs, BKGD and the RESET pins. The internal structure of all those pins is identical, however some of the functionality may be disabled. E.g. for the analog inputs the output drivers, pull-up and pull-down resistors are disabled permanently.

#### A.1.3.2 Analog Reference

This group is made up by the VRH and VRL pins.

#### A.1.3.3 Oscillator

The pins XFC, EXTAL, XTAL dedicated to the oscillator have a nominal 2.5V level. They are supplied by VDDPLL.

#### A.1.3.4 TEST

This pin is used for production testing only.

#### A.1.3.5 VREGEN

This pin is used to enable the on chip voltage regulator.

## A.1.4 Current Injection

Power supply must maintain regulation within operating  $V_{DD5}$  or  $V_{DD}$  range during instantaneous and operating maximum current conditions. If positive injection current ( $V_{in} > V_{DD5}$ ) is greater than  $I_{DD5}$ , the injection current may flow out of VDD5 and could result in external power supply going out of regulation. Ensure external VDD5 load will shunt current greater than maximum injection current. This will be the greatest risk when the MCU is not consuming power; e.g. if no system clock is present, or if clock rate is very low which would reduce overall power consumption.

## A.1.5 Absolute Maximum Ratings

Absolute maximum ratings are stress ratings only. A functional operation under or outside those maxima is not guaranteed. Stress beyond those limits may affect the reliability or cause permanent damage of the device.

This device contains circuitry protecting against damage due to high static voltage or electrical fields; however, it is advised that normal precautions be taken to avoid application of any voltages higher than maximum-rated voltages to this high-impedance circuit. Reliability of operation is enhanced if unused inputs are tied to an appropriate logic voltage level (e.g., either  $V_{SS5}$  or  $V_{DD5}$ ).

**Table A-1 Absolute Maximum Ratings<sup>1</sup>**

Num	Rating	Symbol	Min	Max	Unit
1	I/O, Regulator and Analog Supply Voltage	$V_{DD5}$	-0.3	6.0	V
2	Digital Logic Supply Voltage <sup>2</sup>	$V_{DD}$	-0.3	3.0	V
3	PLL Supply Voltage <sup>2</sup>	$V_{DDPLL}$	-0.3	3.0	V
4	Voltage difference VDDX to VDDR and VDDA	$\Delta V_{DDX}$	-0.3	0.3	V
5	Voltage difference VSSX to VSSR and VSSA	$\Delta V_{SSX}$	-0.3	0.3	V
6	Digital I/O Input Voltage	$V_{IN}$	-0.3	6.0	V
7	Analog Reference	$V_{RH}, V_{RL}$	-0.3	6.0	V
8	XFC, EXTAL, XTAL inputs	$V_{ILV}$	-0.3	3.0	V
9	TEST input	$V_{TEST}$	-0.3	10.0	V
10	Instantaneous Maximum Current Single pin limit for all digital I/O pins <sup>3</sup>	$I_D$	-25	+25	mA
11	Instantaneous Maximum Current Single pin limit for XFC, EXTAL, XTAL <sup>4</sup>	$I_{DL}$	-25	+25	mA
12	Instantaneous Maximum Current Single pin limit for TEST <sup>5</sup>	$I_{DT}$	-0.25	0	mA
13	Storage Temperature Range	$T_{stg}$	-65	155	°C

NOTES:

1. Beyond absolute maximum ratings device might be damaged.

2. The device contains an internal voltage regulator to generate the logic and PLL supply out of the I/O supply.  
The absolute maximum ratings apply when the device is powered from an external source.
3. All digital I/O pins are internally clamped to  $V_{SSX}$  and  $V_{DDX}$ ,  $V_{SSR}$  and  $V_{DDR}$  or  $V_{SSA}$  and  $V_{DDA}$ .
4. Those pins are internally clamped to  $V_{SSPLL}$  and  $V_{DDPLL}$ .
5. This pin is clamped low to  $V_{SSR}$ , but not clamped high. This pin must be tied low in applications.

## A.1.6 ESD Protection and Latch-up Immunity

All ESD testing is in conformity with CDF-AEC-Q100 Stress test qualification for Automotive Grade Integrated Circuits. During the device qualification ESD stresses were performed for the Human Body Model (HBM), the Machine Model (MM) and the Charge Device Model.

A device will be defined as a failure if after exposure to ESD pulses the device no longer meets the device specification. Complete DC parametric and functional testing is performed per the applicable device specification at room temperature followed by hot temperature, unless specified otherwise in the device specification.

**Table A-2 ESD and Latch-up Test Conditions**

Model	Description	Symbol	Value	Unit
Human Body	Series Resistance	R1	1500	Ohm
	Storage Capacitance	C	100	pF
	Number of Pulse per pin positive negative	-	- 3 3	
Machine	Series Resistance	R1	0	Ohm
	Storage Capacitance	C	200	pF
	Number of Pulse per pin positive negative	-	- 3 3	
Latch-up	Minimum input voltage limit		-2.5	V
	Maximum input voltage limit		7.5	V

**Table A-3 ESD and Latch-Up Protection Characteristics**

Num	C	Rating	Symbol	Min	Max	Unit
1	C	Human Body Model (HBM)	$V_{HBM}$	2000	-	V
2	C	Machine Model (MM)	$V_{MM}$	200	-	V
3	C	Charge Device Model (CDM)	$V_{CDM}$	500	-	V
4	C	Latch-up Current at $T_A = 125^\circ\text{C}$ positive negative	$I_{LAT}$	+100 -100	-	mA
5	C	Latch-up Current at $T_A = 27^\circ\text{C}$ positive negative	$I_{LAT}$	+200 -200	-	mA

## A.1.7 Operating Conditions

This chapter describes the operating conditions of the device. Unless otherwise noted those conditions apply to all the following data.

**NOTE:** Please refer to the temperature rating of the device (C, V, M) with regards to the ambient temperature  $T_A$  and the junction temperature  $T_J$ . For power dissipation calculations refer to **Section A.1.8 Power Dissipation and Thermal Characteristics**.

**Table A-4 Operating Conditions**

Rating	Symbol	Min	Typ	Max	Unit
I/O, Regulator and Analog Supply Voltage	$V_{DD5}$	4.5	5	5.25	V
Digital Logic Supply Voltage <sup>1</sup>	$V_{DD}$	2.35	2.5	2.75	V
PLL Supply Voltage <sup>1</sup>	$V_{DDPLL}$	2.35	2.5	2.75	V
Voltage Difference VDDX to VDDR and VDDA	$\Delta V_{DDX}$	-0.1	0	0.1	V
Voltage Difference VSSX to VSSR and VSSA	$\Delta V_{SSX}$	-0.1	0	0.1	V
Oscillator	$f_{osc}$	0.5	-	16	MHz
Bus Frequency	$f_{bus}$	0.5	-	25	MHz
<b>MC9S12DT256C</b>					
Operating Junction Temperature Range	$T_J$	-40	-	100	°C
Operating Ambient Temperature Range <sup>2</sup>	$T_A$	-40	27	85	°C
<b>MC9S12DT256V</b>					
Operating Junction Temperature Range	$T_J$	-40	-	120	°C
Operating Ambient Temperature Range <sup>2</sup>	$T_A$	-40	27	105	°C
<b>MC9S12DT256M</b>					
Operating Junction Temperature Range	$T_J$	-40	-	140	°C
Operating Ambient Temperature Range <sup>2</sup>	$T_A$	-40	27	125	°C

NOTES:

1. The device contains an internal voltage regulator to generate the logic and PLL supply out of the I/O supply. The absolute maximum ratings apply when this regulator is disabled and the device is powered from an external source.
2. Please refer to **Section A.1.8 Power Dissipation and Thermal Characteristics** for more details about the relation between ambient temperature  $T_A$  and device junction temperature  $T_J$ .

## A.1.8 Power Dissipation and Thermal Characteristics

Power dissipation and thermal characteristics are closely related. The user must assure that the maximum operating junction temperature is not exceeded. The average chip-junction temperature ( $T_J$ ) in °C can be obtained from:

$$T_J = T_A + (P_D \cdot \Theta_{JA})$$

$T_J$  = Junction Temperature, [°C]

$T_A$  = Ambient Temperature, [°C]

$P_D$  = Total Chip Power Dissipation, [W]

$\Theta_{JA}$  = Package Thermal Resistance, [°C/W]

The total power dissipation can be calculated from:

$$P_D = P_{INT} + P_{IO}$$

$P_{INT}$  = Chip Internal Power Dissipation, [W]

Two cases with internal voltage regulator enabled and disabled must be considered:

1. Internal Voltage Regulator disabled

$$P_{INT} = I_{DD} \cdot V_{DD} + I_{DDPLL} \cdot V_{DDPLL} + I_{DDA} \cdot V_{DDA}$$

$$P_{IO} = \sum_i R_{DSON} \cdot I_{IO_i}^2$$

$P_{IO}$  is the sum of all output currents on I/O ports associated with VDDX and VDDR.

For  $R_{DSON}$  is valid:

$$R_{DSON} = \frac{V_{OL}}{I_{OL}}; \text{for outputs driven low}$$

respectively

$$R_{DSON} = \frac{V_{DD5} - V_{OH}}{I_{OH}}; \text{for outputs driven high}$$

2. Internal voltage regulator enabled

$$P_{INT} = I_{DDR} \cdot V_{DDR} + I_{DDA} \cdot V_{DDA}$$

$I_{DDR}$  is the current shown in **Table A-7** and not the overall current flowing into VDDR, which additionally contains the current flowing into the external loads with output high.

$$P_{IO} = \sum_i R_{DSON} \cdot I_{IO_i}^2$$

$P_{IO}$  is the sum of all output currents on I/O ports associated with VDDX and VDDR.

**Table A-5 Thermal Package Characteristics<sup>1</sup>**

Num	C	Rating	Symbol	Min	Typ	Max	Unit
1	T	Thermal Resistance LQFP112, single sided PCB <sup>2</sup>	$\theta_{JA}$	-	-	54	°C/W
2	T	Thermal Resistance LQFP112, double sided PCB with 2 internal planes <sup>3</sup>	$\theta_{JA}$	-	-	41	°C/W
3	T	Thermal Resistance LQFP 80, single sided PCB	$\theta_{JA}$	-	-	51	°C/W
4	T	Thermal Resistance LQFP 80, double sided PCB with 2 internal planes	$\theta_{JA}$	-	-	41	°C/W

## NOTES:

1. The values for thermal resistance are achieved by package simulations
2. PC Board according to EIA/JEDEC Standard 51-2
3. PC Board according to EIA/JEDEC Standard 51-7

**A.1.9 I/O Characteristics**

This section describes the characteristics of all 5V I/O pins. All parameters are not always applicable, e.g. not all pins feature pull up/down resistances.

Table A-6 5V I/O Characteristics

Conditions are shown in <b>Table A-4</b> unless otherwise noted							
Num	C	Rating	Symbol	Min	Typ	Max	Unit
1	P	Input High Voltage	$V_{IH}$	$0.65 \cdot V_{DD5}$	-	-	V
	T	Input High Voltage	$V_{IH}$	-	-	$V_{DD5} + 0.3$	V
2	P	Input Low Voltage	$V_{IL}$	-	-	$0.35 \cdot V_{DD5}$	V
	T	Input Low Voltage	$V_{IL}$	$V_{SS5} - 0.3$	-	-	V
3	C	Input Hysteresis	$V_{HYS}$		250		mV
4	P	Input Leakage Current (pins in high impedance input mode) <sup>1</sup> $V_{in} = V_{DD5}$ or $V_{SS5}$	$I_{in}$	-2.5	-	2.5	$\mu A$
5	C	Output High Voltage (pins in output mode) Partial Drive $I_{OH} = -2mA$	$V_{OH}$	$V_{DD5} - 0.8$	-	-	V
6	P	Output High Voltage (pins in output mode) Full Drive $I_{OH} = -10mA$	$V_{OH}$	$V_{DD5} - 0.8$	-	-	V
7	C	Output Low Voltage (pins in output mode) Partial Drive $I_{OL} = +2mA$	$V_{OL}$	-	-	0.8	V
8	P	Output Low Voltage (pins in output mode) Full Drive $I_{OL} = +10mA$	$V_{OL}$	-	-	0.8	V
9	P	Internal Pull Up Device Current, tested at $V_{IL}$ Max.	$I_{PUL}$	-	-	-130	$\mu A$
10	C	Internal Pull Up Device Current, tested at $V_{IH}$ Min.	$I_{PUH}$	-10	-	-	$\mu A$
11	P	Internal Pull Down Device Current, tested at $V_{IH}$ Min.	$I_{PDH}$	-	-	130	$\mu A$
12	C	Internal Pull Down Device Current, tested at $V_{IL}$ Max.	$I_{PDL}$	10	-	-	$\mu A$
13	D	Input Capacitance	$C_{in}$		6	-	pF
14	T	Injection current <sup>2</sup> Single Pin limit Total Device Limit. Sum of all injected currents	$I_{ICS}$ $I_{ICP}$	-2.5 -25	-	2.5 25	mA
15	P	Port H, J, P Interrupt Input Pulse filtered <sup>3</sup>	$t_{PULSE}$			3	$\mu s$
16	P	Port H, J, P Interrupt Input Pulse passed <sup>3</sup>	$t_{PULSE}$	10			$\mu s$

## NOTES:

1. Maximum leakage current occurs at maximum operating temperature. Current decreases by approximately one-half for each 8 C to 12 C in the temperature range from 50 C to 125 C.
2. Refer to **Section A.1.4 Current Injection**, for more details
3. Parameter only applies in STOP or Pseudo STOP mode.



## A.1.10 Supply Currents

This section describes the current consumption characteristics of the device as well as the conditions for the measurements.

### A.1.10.1 Measurement Conditions

All measurements are without output loads. Unless otherwise noted the currents are measured in single chip mode, internal voltage regulator enabled and at 25MHz bus frequency using a 4MHz oscillator in Colpitts mode. Production testing is performed using a square wave signal at the EXTAL input.

### A.1.10.2 Additional Remarks

In expanded modes the currents flowing in the system are highly dependent on the load at the address, data and control signals as well as on the duty cycle of those signals. No generally applicable numbers can be

given. A very good estimate is to take the single chip currents and add the currents due to the external loads.

**Table A-7 Supply Current Characteristics**

Conditions are shown in <b>Table A-4</b> unless otherwise noted							
Num	C	Rating	Symbol	Min	Typ	Max	Unit
1	P	Run supply currents Single Chip, Internal regulator enabled	$I_{DD5}$			65	mA
2	P P	Wait Supply current All modules enabled, PLL on only RTI enabled <sup>1</sup>	$I_{DDW}$			40 5	mA
3	C P C C P C P C P	Pseudo Stop Current (RTI and COP disabled) <sup>1, 2</sup> -40°C 27°C 70°C 85°C "C" Temp Option 100°C 105°C "V" Temp Option 120°C 125°C "M" Temp Option 140°C	$I_{DDPS}$		370 400 450 550 600 650 800 850 1200	500 1600 2100 5000	μA
4	C C C C C C C	Pseudo Stop Current (RTI and COP enabled) <sup>1, 2</sup> -40°C 27°C 70°C 85°C 105°C 125°C 140°C	$I_{DDPS}$		570 600 650 750 850 1200 1500		μA
5	C P C C P C P C P	Stop Current <sup>2</sup> -40°C 27°C 70°C 85°C "C" Temp Option 100°C 105°C "V" Temp Option 120°C 125°C "M" Temp Option 140°C	$I_{DDS}$		12 25 100 130 160 200 350 400 600	100 1200 1700 5000	μA

NOTES:

1. PLL off

2. At those low power dissipation levels  $T_J = T_A$  can be assumed

## A.2 ATD Characteristics

This section describes the characteristics of the analog to digital converter.

### A.2.1 ATD Operating Characteristics

The **Table A-8** shows conditions under which the ATD operates.

The following constraints exist to obtain full-scale, full range results:

$V_{SSA} \leq V_{RL} \leq V_{IN} \leq V_{RH} \leq V_{DDA}$ . This constraint exists since the sample buffer amplifier can not drive beyond the power supply levels that it ties to. If the input level goes outside of this range it will effectively be clipped.

**Table A-8 ATD Operating Characteristics**

Conditions are shown in <b>Table A-4</b> unless otherwise noted							
Num	C	Rating	Symbol	Min	Typ	Max	Unit
1	D	Reference Potential	Low	$V_{RL}$	$V_{SSA}$	$V_{DDA}/2$	V
			High	$V_{RH}$	$V_{DDA}/2$	$V_{DDA}$	V
2	C	Differential Reference Voltage <sup>1</sup>	$V_{RH}-V_{RL}$	4.50	5.00	5.25	V
3	D	ATD Clock Frequency	$f_{ATDCLK}$	0.5		2.0	MHz
4	D	ATD 10-Bit Conversion Period	Clock Cycles <sup>2</sup> Conv, Time at 2.0MHz ATD Clock $f_{ATDCLK}$	$N_{CONV10}$	14	28	Cycles $\mu$ s
				$T_{CONV10}$	7	14	
5	D	ATD 8-Bit Conversion Period	Clock Cycles <sup>2</sup> Conv, Time at 2.0MHz ATD Clock $f_{ATDCLK}$	$N_{CONV8}$	12	26	Cycles $\mu$ s
				$T_{CONV8}$	6	13	
6	D	Recovery Time ( $V_{DDA}=5.0$ Volts)	$t_{REC}$			20	$\mu$ s
7	P	Reference Supply current 2 ATD blocks on	$I_{REF}$			0.750	mA
8	P	Reference Supply current 1 ATD block on	$I_{REF}$			0.375	mA

NOTES:

1. Full accuracy is not guaranteed when differential voltage is less than 4.50V
2. The minimum time assumes a final sample period of 2 ATD clocks cycles while the maximum time assumes a final sample period of 16 ATD clocks.

### A.2.2 Factors influencing accuracy

Three factors - source resistance, source capacitance and current injection - have an influence on the accuracy of the ATD.

#### A.2.2.1 Source Resistance:

Due to the input pin leakage current as specified in **Table A-6** in conjunction with the source resistance there will be a voltage drop from the signal source to the ATD input. The maximum source resistance  $R_S$

specifies results in an error of less than 1/2 LSB (2.5mV) at the maximum leakage current. If device or operating conditions are less than worst case or leakage-induced error is acceptable, larger values of source resistance is allowed.

### A.2.2.2 Source Capacitance

When sampling an additional internal capacitor is switched to the input. This can cause a voltage drop due to charge sharing with the external and the pin capacitance. For a maximum sampling error of the input voltage  $\leq 1\text{LSB}$ , then the external filter capacitor,  $C_f \geq 1024 * (C_{\text{INS}} - C_{\text{INN}})$ .

### A.2.2.3 Current Injection

There are two cases to consider.

1. A current is injected into the channel being converted. The channel being stressed has conversion values of \$3FF (\$FF in 8-bit mode) for analog inputs greater than  $V_{\text{RH}}$  and \$000 for values less than  $V_{\text{RL}}$  unless the current is higher than specified as disruptive condition.
2. Current is injected into pins in the neighborhood of the channel being converted. A portion of this current is picked up by the channel (coupling ratio K), This additional current impacts the accuracy of the conversion depending on the source resistance.

The additional input voltage error on the converted channel can be calculated as  $V_{\text{ERR}} = K * R_S * I_{\text{INJ}}$ , with  $I_{\text{INJ}}$  being the sum of the currents injected into the two pins adjacent to the converted channel.

**Table A-9 ATD Electrical Characteristics**

Conditions are shown in <b>Table A-4</b> unless otherwise noted							
Num	C	Rating	Symbol	Min	Typ	Max	Unit
1	C	Max input Source Resistance	$R_S$	-	-	1	$K\Omega$
2	T	Total Input Capacitance Non Sampling Sampling	$C_{\text{INN}}$ $C_{\text{INS}}$			10 22	pF
3	C	Disruptive Analog Input Current	$I_{\text{NA}}$	-2.5		2.5	mA
4	C	Coupling Ratio positive current injection	$K_p$			$10^{-4}$	A/A
5	C	Coupling Ratio negative current injection	$K_n$			$10^{-2}$	A/A

## A.2.3 ATD accuracy

**Table A-10** specifies the ATD conversion performance excluding any errors due to current injection, input capacitance and source resistance.

**Table A-10 ATD Conversion Performance**

Conditions are shown in <b>Table A-4</b> unless otherwise noted $V_{REF} = V_{RH} - V_{RL} = 5.12V$ . Resulting to one 8 bit count = 20mV and one 10 bit count = 5mV $f_{ATDCLK} = 2.0MHz$							
Num	C	Rating	Symbol	Min	Typ	Max	Unit
1	P	10-Bit Resolution	LSB		5		mV
2	P	10-Bit Differential Nonlinearity	DNL	-1		1	Counts
3	P	10-Bit Integral Nonlinearity	INL	-2.5	±1.5	2.5	Counts
4	P	10-Bit Absolute Error <sup>1</sup>	AE	-3	±2.0	3	Counts
5	P	8-Bit Resolution	LSB		20		mV
6	P	8-Bit Differential Nonlinearity	DNL	-0.5		0.5	Counts
7	P	8-Bit Integral Nonlinearity	INL	-1.0	±0.5	1.0	Counts
8	P	8-Bit Absolute Error <sup>1</sup>	AE	-1.5	±1.0	1.5	Counts

NOTES:

1. These values include the quantization error which is inherently 1/2 count for any A/D converter.

For the following definitions see also **Figure A-1**.

Differential Non-Linearity (DNL) is defined as the difference between two adjacent switching steps.

$$DNL(i) = \frac{V_i - V_{i-1}}{1LSB} - 1$$

The Integral Non-Linearity (INL) is defined as the sum of all DNLs:

$$INL(n) = \sum_{i=1}^n DNL(i) = \frac{V_n - V_0}{1LSB} - n$$

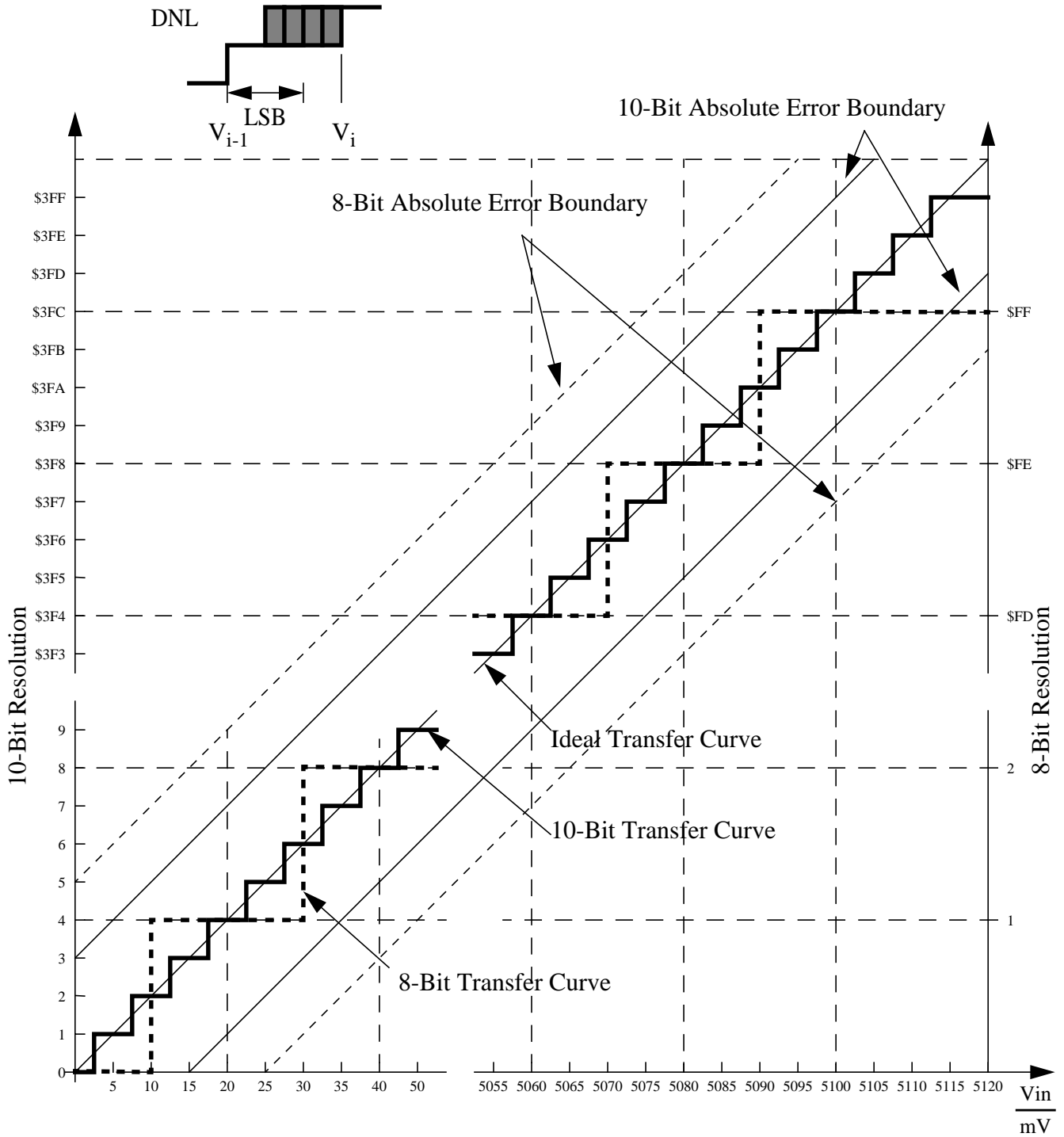

Figure A-1 ATD Accuracy Definitions

**NOTE:** Figure A-1 shows only definitions, for specification values refer to Table A-10.

## A.3 NVM, Flash and EEPROM

**NOTE:** Unless otherwise noted the abbreviation NVM (Non Volatile Memory) is used for both Flash and EEPROM.

### A.3.1 NVM timing

The time base for all NVM program or erase operations is derived from the oscillator. A minimum oscillator frequency  $f_{\text{NVMOSC}}$  is required for performing program or erase operations. The NVM modules do not have any means to monitor the frequency and will not prevent program or erase operation at frequencies above or below the specified minimum. Attempting to program or erase the NVM modules at a lower frequency a full program or erase transition is not assured.

The Flash and EEPROM program and erase operations are timed using a clock derived from the oscillator using the FCLKDIV and ECLKDIV registers respectively. The frequency of this clock must be set within the limits specified as  $f_{\text{NVMOP}}$ .

The minimum program and erase times shown in **Table A-11** are calculated for maximum  $f_{\text{NVMOP}}$  and maximum  $f_{\text{bus}}$ . The maximum times are calculated for minimum  $f_{\text{NVMOP}}$  and a  $f_{\text{bus}}$  of 2MHz.

#### A.3.1.1 Single Word Programming

The programming time for single word programming is dependant on the bus frequency as a well as on the frequency  $f_{\text{NVMOP}}$  and can be calculated according to the following formula.

$$t_{\text{swpgm}} = 9 \cdot \frac{1}{f_{\text{NVMOP}}} + 25 \cdot \frac{1}{f_{\text{bus}}}$$

#### A.3.1.2 Burst Programming

This applies only to the Flash where up to 32 words in a row can be programmed consecutively using burst programming by keeping the command pipeline filled. The time to program a consecutive word can be calculated as:

$$t_{\text{bwpgm}} = 4 \cdot \frac{1}{f_{\text{NVMOP}}} + 9 \cdot \frac{1}{f_{\text{bus}}}$$

The time to program a whole row is:

$$t_{\text{brpgm}} = t_{\text{swpgm}} + 31 \cdot t_{\text{bwpgm}}$$

Burst programming is more than 2 times faster than single word programming.

### A.3.1.3 Sector Erase

Erasing a 512 byte Flash sector or a 4 byte EEPROM sector takes:

$$t_{\text{era}} \approx 4000 \cdot \frac{1}{f_{\text{NVMOP}}}$$

The setup time can be ignored for this operation.

### A.3.1.4 Mass Erase

Erasing a NVM block takes:

$$t_{\text{mass}} \approx 20000 \cdot \frac{1}{f_{\text{NVMOP}}}$$

The setup time can be ignored for this operation.

### A.3.1.5 Blank Check

The time it takes to perform a blank check on the Flash or EEPROM is dependant on the **location** of the first non-blank word starting at relative address zero. It takes one bus cycle per word to verify plus a setup of the command.

$$t_{\text{check}} \approx \text{location} \cdot t_{\text{cyc}} + 10 \cdot t_{\text{cyc}}$$

**Table A-11 NVM Timing Characteristics**

Conditions are shown in <b>Table A-4</b> unless otherwise noted							
Num	C	Rating	Symbol	Min	Typ	Max	Unit
1	D	External Oscillator Clock (MC9S12DT256C< V, M)	$f_{\text{NVMOSC}}$	0.5		50 <sup>1</sup>	MHz
2	D	Bus frequency for Programming or Erase Operations	$f_{\text{NVMBUS}}$	1			MHz
3	D	Operating Frequency	$f_{\text{NVMOP}}$	150		200	kHz
4	P	Single Word Programming Time	$t_{\text{swpgm}}$	46 <sup>2</sup>		74.5 <sup>3</sup>	$\mu\text{s}$
5	D	Flash Burst Programming consecutive word <sup>4</sup>	$t_{\text{bwpgm}}$	20.4 <sup>2</sup>		31 <sup>3</sup>	$\mu\text{s}$
6	D	Flash Burst Programming Time for 32 Words <sup>4</sup>	$t_{\text{brpgm}}$	678.4 <sup>2</sup>		1035.5 <sup>3</sup>	$\mu\text{s}$
7	P	Sector Erase Time	$t_{\text{era}}$	20 <sup>5</sup>		26.7 <sup>3</sup>	ms
8	P	Mass Erase Time	$t_{\text{mass}}$	100 <sup>5</sup>		133 <sup>3</sup>	ms
9	D	Blank Check Time Flash per block	$t_{\text{check}}$	11 <sup>6</sup>		32778 <sup>7</sup>	$t_{\text{cyc}}$
10	D	Blank Check Time EEPROM per block	$t_{\text{check}}$	11 <sup>6</sup>		2058 <sup>7</sup>	$t_{\text{cyc}}$

NOTES:

- Restrictions for oscillator in crystal mode apply!
- Minimum Programming times are achieved under maximum NVM operating frequency  $f_{\text{NVMOP}}$  and maximum bus frequency  $f_{\text{bus}}$ .



3. Maximum Erase and Programming times are achieved under particular combinations of  $f_{\text{NVMOP}}$  and bus frequency  $f_{\text{bus}}$ . Refer to formulae in Sections **A.3.1.1 - A.3.1.4** for guidance.
4. Burst Programming operations are not applicable to EEPROM
5. Minimum Erase times are achieved under maximum NVM operating frequency  $f_{\text{NVMOP}}$ .
6. Minimum time, if first word in the array is not blank
7. Maximum time to complete check on an erased block

## A.3.2 NVM Reliability

The reliability of the NVM blocks is guaranteed by stress test during qualification, constant process monitors and burn-in to screen early life failures. The program/erase cycle count on the sector is incremented every time a sector or mass erase event is executed

**Table A-12 NVM Reliability Characteristics<sup>1</sup>**

Conditions are shown in <b>Table A-4</b> unless otherwise noted							
Num	C	Rating	Symbol	Min	Typ	Max	Unit
Flash Reliability Characteristics							
1	C	Data retention after 10,000 program/erase cycles at an average junction temperature of $T_{Javg} \leq 85^{\circ}\text{C}$	$t_{FLRET}$	15	$100^2$	—	Years
2	C	Data retention with <100 program/erase cycles at an average junction temperature $T_{Javg} \leq 85^{\circ}\text{C}$		20	$100^2$	—	
3	C	Number of program/erase cycles ( $-40^{\circ}\text{C} \leq T_J \leq 0^{\circ}\text{C}$ )	$n_{FL}$	10,000	—	—	Cycles
4	C	Number of program/erase cycles ( $0^{\circ}\text{C} \leq T_J \leq 140^{\circ}\text{C}$ )		10,000	$100,000^3$	—	
EEPROM Reliability Characteristics							
5	C	Data retention after up to 100,000 program/erase cycles at an average junction temperature of $T_{Javg} \leq 85^{\circ}\text{C}$	$t_{EEPRET}$	15	$100^2$	—	Years
6	C	Data retention with <100 program/erase cycles at an average junction temperature $T_{Javg} \leq 85^{\circ}\text{C}$		20	$100^2$	—	
7	C	Number of program/erase cycles ( $-40^{\circ}\text{C} \leq T_J \leq 0^{\circ}\text{C}$ )	$n_{EEP}$	10,000	—	—	Cycles
8	C	Number of program/erase cycles ( $0^{\circ}\text{C} < T_J \leq 140^{\circ}\text{C}$ )		100,000	$300,000^3$	—	

**NOTES:**

- $T_{Javg}$  will not exceed  $85^{\circ}\text{C}$  considering a typical temperature profile over the lifetime of a consumer, industrial or automotive application.
- Typical data retention values are based on intrinsic capability of the technology measured at high temperature and de-rated to  $25^{\circ}\text{C}$  using the Arrhenius equation. For additional information on how Freescale defines Typical Data Retention, please refer to Engineering Bulletin EB618.
- Spec table quotes typical endurance evaluated at  $25^{\circ}\text{C}$  for this product family, typical endurance at various temperature can be estimated using the graph below. For additional information on how Freescale defines Typical Endurance, please refer to Engineering Bulletin EB619.

Figure A-2 Typical Endurance vs Temperature

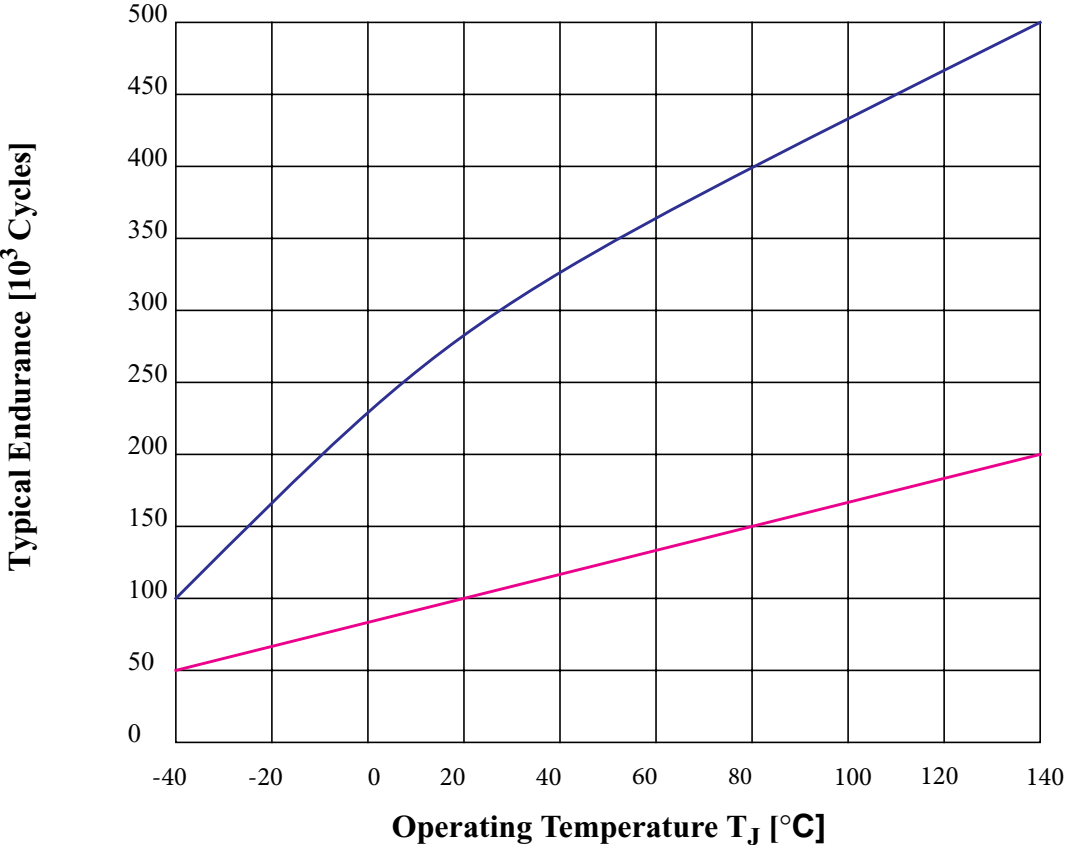

--- Flash  
--- EEPROM



## A.4 Voltage Regulator

The on-chip voltage regulator is intended to supply the internal logic and oscillator circuits. No external DC load is allowed.

**Table A-13 Voltage Regulator Recommended Load Capacitances**

Rating	Symbol	Min	Typ	Max	Unit
Load Capacitance on VDD1, 2	$C_{LVDD}$		220		nF
Load Capacitance on VDDPLL	$C_{LVDDfcPLL}$		220		nF



## A.5 Reset, Oscillator and PLL

This section summarizes the electrical characteristics of the various startup scenarios for Oscillator and Phase-Locked-Loop (PLL).

### A.5.1 Startup

**Table A-14** summarizes several startup characteristics explained in this section. Detailed description of the startup behavior can be found in the Clock and Reset Generator (CRG) Block Guide.

**Table A-14 Startup Characteristics**

Conditions are shown in <b>Table A-4</b> unless otherwise noted							
Num	C	Rating	Symbol	Min	Typ	Max	Unit
1	T	POR release level	$V_{PORR}$			2.07	V
2	T	POR assert level	$V_{PORA}$	0.97			V
3	D	Reset input pulse width, minimum input time	$PW_{RSTL}$	2			$t_{osc}$
4	D	Startup from Reset	$n_{RST}$	192		196	$n_{osc}$
5	D	Interrupt pulse width, $\overline{IRQ}$ edge-sensitive mode	$PW_{IRQ}$	20			ns
6	D	Wait recovery startup time	$t_{WRS}$			14	$t_{cyc}$

#### A.5.1.1 POR

The release level  $V_{PORR}$  and the assert level  $V_{PORA}$  are derived from the  $V_{DD}$  Supply. They are also valid if the device is powered externally. After releasing the POR reset the oscillator and the clock quality check are started. If after a time  $t_{CQOUT}$  no valid oscillation is detected, the MCU will start using the internal self clock. The fastest startup time possible is given by  $n_{uposc}$ .

#### A.5.1.2 SRAM Data Retention

Provided an appropriate external reset signal is applied to the MCU, preventing the CPU from executing code when  $V_{DD5}$  is out of specification limits, the SRAM contents integrity is guaranteed if after the reset the PORF bit in the CRG Flags Register has not been set.

#### A.5.1.3 External Reset

When external reset is asserted for a time greater than  $PW_{RSTL}$  the CRG module generates an internal reset, and the CPU starts fetching the reset vector without doing a clock quality check, if there was an oscillation before reset.

#### A.5.1.4 Stop Recovery

Out of STOP the controller can be woken up by an external interrupt. A clock quality check as after POR is performed before releasing the clocks to the system.

### A.5.1.5 Pseudo Stop and Wait Recovery

The recovery from Pseudo STOP and Wait are essentially the same since the oscillator was not stopped in both modes. The controller can be woken up by internal or external interrupts. After  $t_{wrs}$  the CPU starts fetching the interrupt vector.

## A.5.2 Oscillator

The device features an internal Colpitts and Pierce oscillator. The selection of Colpitts oscillator or Pierce oscillator/external clock depends on the  $\overline{XCLKS}$  signal which is sampled during reset. By asserting the  $\overline{XCLKS}$  input during reset this oscillator can be bypassed allowing the input of a square wave. Before asserting the oscillator to the internal system clocks the quality of the oscillation is checked for each start from either power-on, STOP or oscillator fail.  $t_{CQOUT}$  specifies the maximum time before switching to the internal self clock mode after POR or STOP if a proper oscillation is not detected. The quality check also determines the minimum oscillator start-up time  $t_{UPOSC}$ . The device also features a clock monitor. A Clock Monitor Failure is asserted if the frequency of the incoming clock signal is below the Assert Frequency  $f_{CMFA}$ .

**Table A-15 Oscillator Characteristics**

Conditions are shown in <b>Table A-4</b> unless otherwise noted							
Num	C	Rating	Symbol	Min	Typ	Max	Unit
1a	C	Crystal oscillator range (Colpitts)	$f_{OSC}$	0.5		16	MHz
1b	C	Crystal oscillator range (Pierce) <sup>1(4)</sup>	$f_{OSC}$	0.5		40	MHz
2	P	Startup Current	$i_{OSC}$	100			$\mu A$
3	C	Oscillator start-up time (Colpitts)	$t_{UPOSC}$		$8^2$	$100^3$	ms
4	D	Clock Quality check time-out	$t_{CQOUT}$	0.45		2.5	s
5	P	Clock Monitor Failure Assert Frequency	$f_{CMFA}$	50	100	200	KHz
6	P	External square wave input frequency <sup>4</sup>	$f_{EXT}$	0.5		50	MHz
7	D	External square wave pulse width low	$t_{EXTL}$	9.5			ns
8	D	External square wave pulse width high	$t_{EXTH}$	9.5			ns
9	D	External square wave rise time	$t_{EXTR}$			1	ns
10	D	External square wave fall time	$t_{EXTF}$			1	ns
11	D	Input Capacitance (EXTAL, XTAL pins)	$C_{IN}$		7		pF
12	C	DC Operating Bias in Colpitts Configuration on EXTAL Pin	$V_{DCBIAS}$		1.1		V

**NOTES:**

1. Depending on the crystal a damping series resistor might be necessary
2.  $f_{osc} = 4\text{MHz}$ ,  $C = 22\text{pF}$ .
3. Maximum value is for extreme cases using high Q, low frequency crystals
4.  $\overline{XCLKS} = 0$  during reset



### A.5.3 Phase Locked Loop

The oscillator provides the reference clock for the PLL. The PLL's Voltage Controlled Oscillator (VCO) is also the system clock source in self clock mode.

#### A.5.3.1 XFC Component Selection

This section describes the selection of the XFC components to achieve a good filter characteristics.

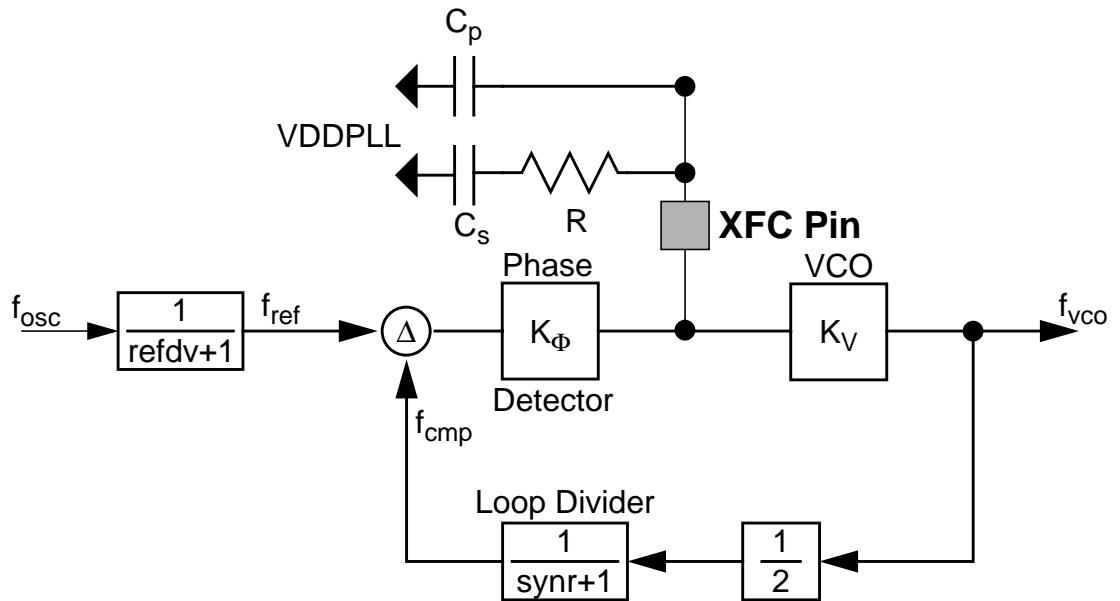

**Figure A-3 Basic PLL functional diagram**

The following procedure can be used to calculate the resistance and capacitance values using typical values for  $K_1$ ,  $f_1$  and  $i_{ch}$  from **Table A-16**.

The grey boxes show the calculation for  $f_{VCO} = 50\text{MHz}$  and  $f_{ref} = 1\text{MHz}$ . E.g., these frequencies are used for  $f_{OSC} = 4\text{MHz}$  and a  $25\text{MHz}$  bus clock.

The VCO Gain at the desired VCO frequency is approximated by:

$$K_V = K_1 \cdot e^{\frac{(f_1 - f_{VCO})}{K_1 \cdot 1V}} = -100 \cdot e^{\frac{(60 - 50)}{-100}} = -90.48\text{MHz/V}$$

The phase detector relationship is given by:

$$K_\Phi = -|i_{ch}| \cdot K_V = 316.7\text{Hz}/\Omega$$

$i_{ch}$  is the current in tracking mode.

The loop bandwidth  $f_C$  should be chosen to fulfill the Gardner's stability criteria by at least a factor of 10, typical values are 50.  $\zeta = 0.9$  ensures a good transient response.

$$f_C < \frac{2 \cdot \zeta \cdot f_{\text{ref}}}{\pi \cdot (\zeta + \sqrt{1 + \zeta^2})} \cdot \frac{1}{10} \rightarrow f_C < \frac{f_{\text{ref}}}{4 \cdot 10}; (\zeta = 0.9)$$

$$f_C < 25\text{kHz}$$

And finally the frequency relationship is defined as

$$n = \frac{f_{\text{VCO}}}{f_{\text{ref}}} = 2 \cdot (\text{synr} + 1) = 50$$

With the above values the resistance can be calculated. The example is shown for a loop bandwidth  $f_C=10\text{kHz}$ :

$$R = \frac{2 \cdot \pi \cdot n \cdot f_C}{K_\Phi} = 2 \cdot \pi \cdot 50 \cdot 10\text{kHz} / (316.7\text{Hz}/\Omega) = 9.9\text{k}\Omega \approx 10\text{k}\Omega$$

The capacitance  $C_s$  can now be calculated as:

$$C_s = \frac{2 \cdot \zeta^2}{\pi \cdot f_C \cdot R} \approx \frac{0.516}{f_C \cdot R}; (\zeta = 0.9) = 5.19\text{nF} \approx 4.7\text{nF}$$

The capacitance  $C_p$  should be chosen in the range of:

$$C_s / 20 \leq C_p \leq C_s / 10 \quad C_p = 470\text{pF}$$

### A.5.3.2 Jitter Information

The basic functionality of the PLL is shown in **Figure A-3**. With each transition of the clock  $f_{\text{cmp}}$ , the deviation from the reference clock  $f_{\text{ref}}$  is measured and input voltage to the VCO is adjusted accordingly. The adjustment is done continuously with no abrupt changes in the clock output frequency. Noise, voltage, temperature and other factors cause slight variations in the control loop resulting in a clock jitter. This jitter affects the real minimum and maximum clock periods as illustrated in **Figure A-4**.

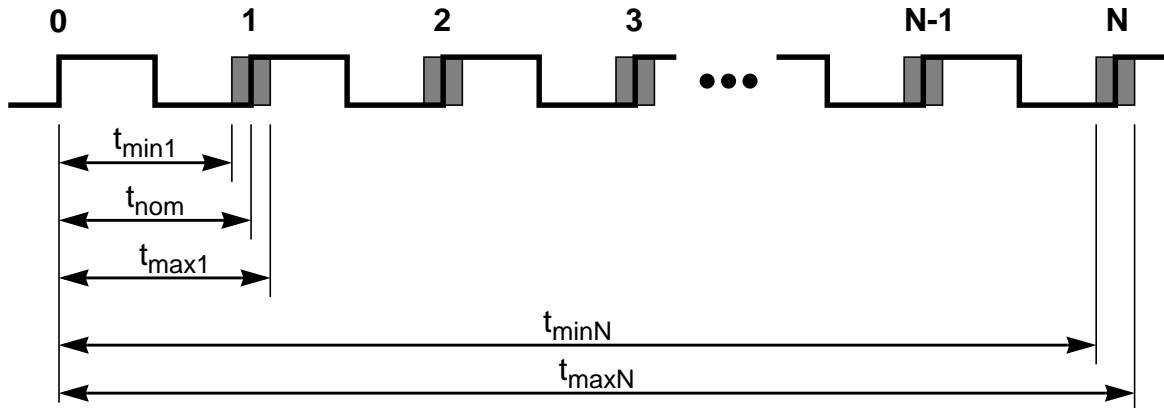

**Figure A-4 Jitter Definitions**

The relative deviation of  $t_{nom}$  is at its maximum for one clock period, and decreases towards zero for larger number of clock periods ( $N$ ).

Defining the jitter as:

$$J(N) = \max\left(\left|1 - \frac{t_{max}(N)}{N \cdot t_{nom}}\right|, \left|1 - \frac{t_{min}(N)}{N \cdot t_{nom}}\right|\right)$$

For  $N < 100$ , the following equation is a good fit for the maximum jitter:

$$J(N) = \frac{j_1}{\sqrt{N}} + j_2$$

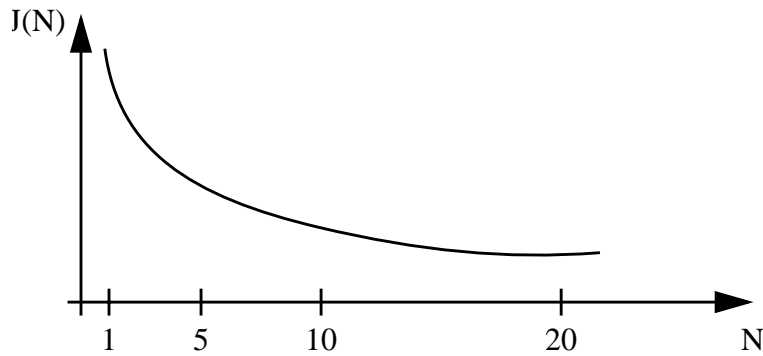

**Figure A-5 Maximum bus clock jitter approximation**

This is very important to notice with respect to timers, serial modules where a pre-scaler will eliminate the effect of the jitter to a large extent.

**Table A-16 PLL Characteristics**

Conditions are shown in <b>Table A-4</b> unless otherwise noted							
Num	C	Rating	Symbol	Min	Typ	Max	Unit
1	P	Self Clock Mode frequency	$f_{SCM}$	1		5.5	MHz
2	D	VCO locking range	$f_{VCO}$	8		50	MHz
3	D	Lock Detector transition from Acquisition to Tracking mode	$ \Delta_{trk} $	3		4	% <sup>1</sup>
4	D	Lock Detection	$ \Delta_{Lock} $	0		1.5	% <sup>(1)</sup>
5	D	Un-Lock Detection	$ \Delta_{unt} $	0.5		2.5	% <sup>(1)</sup>
6	D	Lock Detector transition from Tracking to Acquisition mode	$ \Delta_{unt} $	6		8	% <sup>(1)</sup>
7	C	PLLON Total Stabilization delay (Auto Mode) <sup>2</sup>	$t_{stab}$		0.5		ms
8	D	PLLON Acquisition mode stabilization delay <sup>(2)</sup>	$t_{acq}$		0.3		ms
9	D	PLLON Tracking mode stabilization delay <sup>(2)</sup>	$t_{al}$		0.2		ms
10	D	Fitting parameter VCO loop gain	$K_1$		-100		MHz/V
11	D	Fitting parameter VCO loop frequency	$f_1$		60		MHz
12	D	Charge pump current acquisition mode	$ i_{ch} $		38.5		$\mu A$
13	D	Charge pump current tracking mode	$ i_{ch} $		3.5		$\mu A$
14	C	Jitter fit parameter 1 <sup>(2)</sup>	$j_1$			1.1	%
15	C	Jitter fit parameter 2 <sup>(2)</sup>	$j_2$			0.13	%

NOTES:

1. % deviation from target frequency

2.  $f_{osc} = 4\text{MHz}$ ,  $f_{BUS} = 25\text{MHz}$  equivalent  $f_{VCO} = 50\text{MHz}$ : REF DV = #03, SYN R = #018,  $C_s = 4.7\text{nF}$ ,  $C_p = 470\text{pF}$ ,  $R_s = 10\text{K}\Omega$ .

## A.6 MSCAN

**Table A-17 MSCAN Wake-up Pulse Characteristics**

Conditions are shown in <b>Table A-4</b> unless otherwise noted							
Num	C	Rating	Symbol	Min	Typ	Max	Unit
1	P	MSCAN Wake-up dominant pulse filtered	$t_{WUP}$			2	$\mu\text{s}$
2	P	MSCAN Wake-up dominant pulse pass	$t_{WUP}$	5			$\mu\text{s}$



## A.7 SPI

This section provides electrical parametrics and ratings for the SPI.

In **Table A-18** the measurement conditions are listed.

**Table A-18 Measurement Conditions**

Description	Value	Unit
Drive mode	full drive mode	—
Load capacitance $C_{LOAD}$ , on all outputs	50	pF
Thresholds for delay measurement points	(20% / 80%) VDDX	V

### A.7.1 Master Mode

In **Figure A-6** the timing diagram for master mode with transmission format CPHA=0 is depicted.

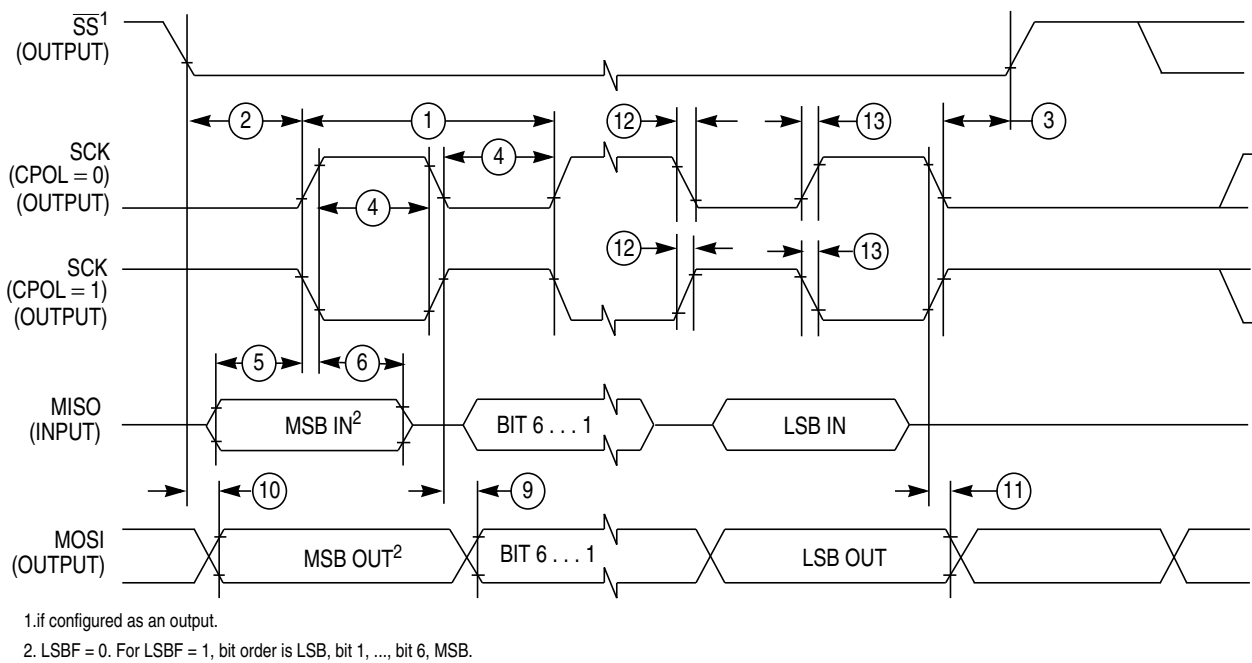

**Figure A-6 SPI Master Timing (CPHA=0)**

In **Figure A-7** the timing diagram for master mode with transmission format CPHA=1 is depicted.

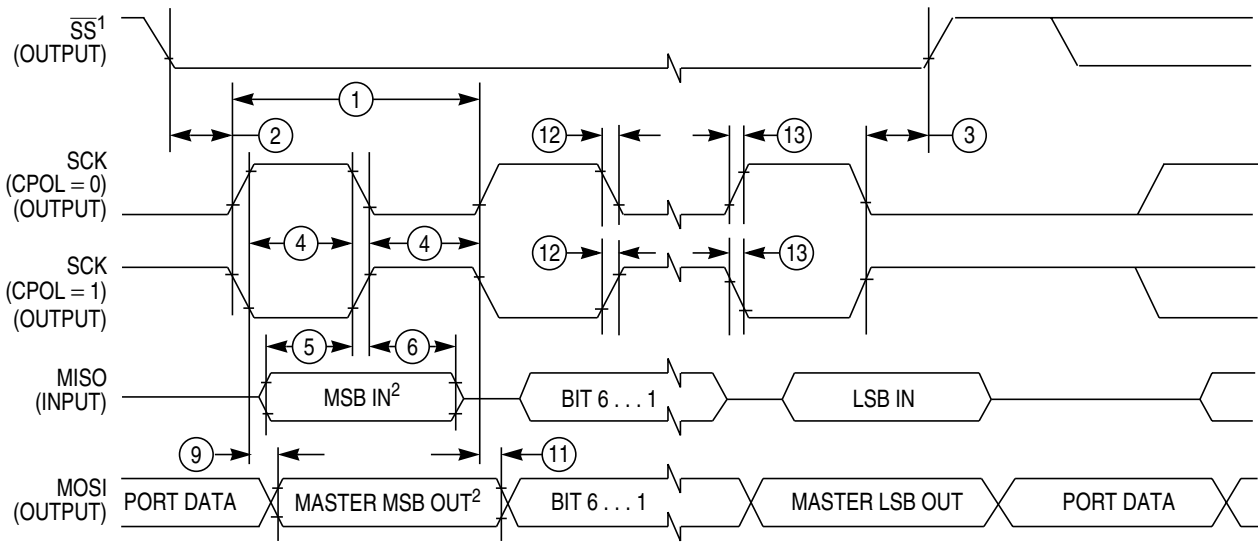

1. If configured as output  
 2. LSBF = 0. For LSBF = 1, bit order is LSB, bit 1, ..., bit 6, MSB.

**Figure A-7 SPI Master Timing (CPHA=1)**

In **Table A-19** the timing characteristics for master mode are listed.

**Table A-19 SPI Master Mode Timing Characteristics**

Num	Characteristic	Symbol				Unit
			Min	Typ	Max	
1	SCK Frequency	$f_{sck}$	1/2048	—	1/2	$f_{bus}$
1	SCK Period	$t_{sck}$	2	—	2048	$t_{bus}$
2	Enable Lead Time	$t_{lead}$	—	1/2	—	$t_{sck}$
3	Enable Lag Time	$t_{lag}$	—	1/2	—	$t_{sck}$
4	Clock (SCK) High or Low Time	$t_{wsck}$	—	1/2	—	$t_{sck}$
5	Data Setup Time (Inputs)	$t_{su}$	8	—	—	ns
6	Data Hold Time (Inputs)	$t_{hi}$	8	—	—	ns
9	Data Valid after SCK Edge	$t_{vsck}$	—	—	30	ns
10	Data Valid after $\overline{SS}$ fall (CPHA=0)	$t_{vss}$	—	—	15	ns
11	Data Hold Time (Outputs)	$t_{ho}$	20	—	—	ns
12	Rise and Fall Time Inputs	$t_{rfi}$	—	—	8	ns
13	Rise and Fall Time Outputs	$t_{rfo}$	—	—	8	ns



## A.7.2 Slave Mode

In **Figure A-8** the timing diagram for slave mode with transmission format CPHA=0 is depicted.

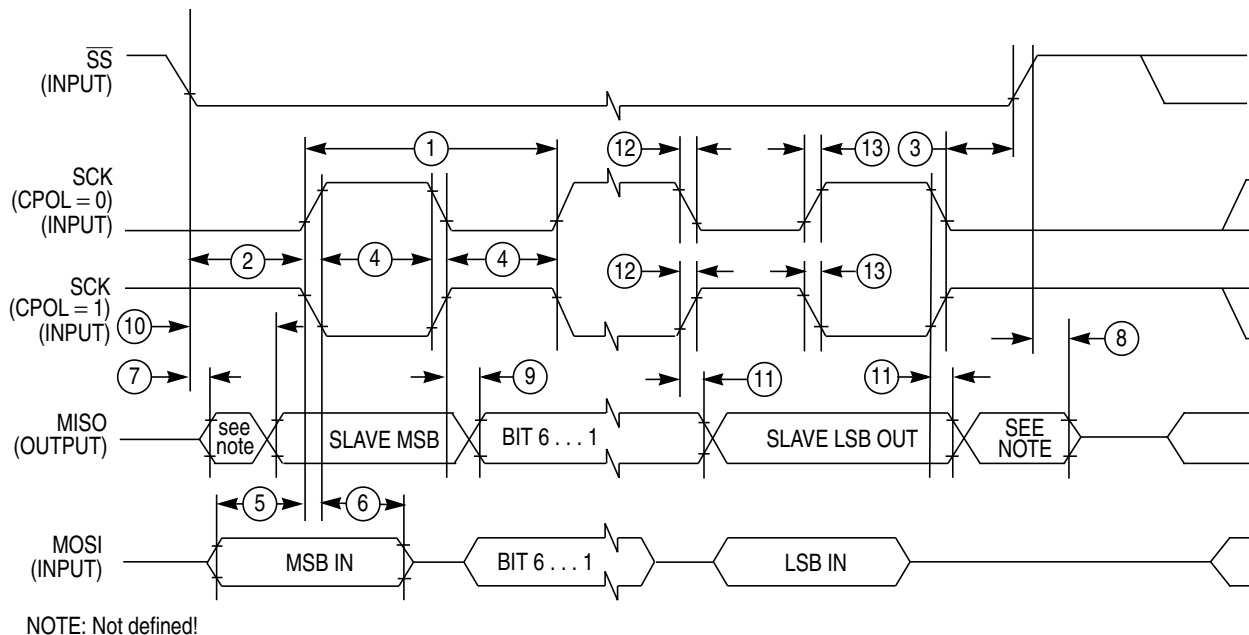

**Figure A-8 SPI Slave Timing (CPHA=0)**

In **Figure A-9** the timing diagram for slave mode with transmission format CPHA=1 is depicted.

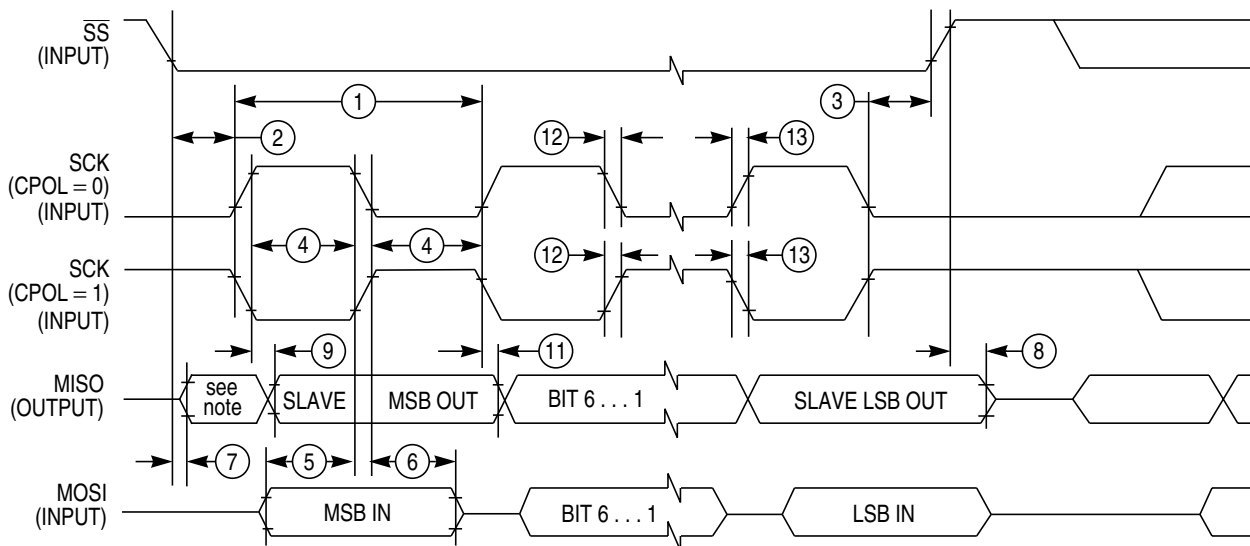

NOTE: Not defined!

**Figure A-9 SPI Slave Timing (CPHA=1)**

In **Table A-20** the timing characteristics for slave mode are listed.

**Table A-20 SPI Slave Mode Timing Characteristics**

Num	Characteristic	Symbol				Unit
			Min	Typ	Max	
1	SCK Frequency	$f_{sck}$	DC	—	1/4	$f_{bus}$
1	SCK Period	$t_{sck}$	4	—	$\infty$	$t_{bus}$
2	Enable Lead Time	$t_{lead}$	4	—	—	$t_{bus}$
3	Enable Lag Time	$t_{lag}$	4	—	—	$t_{bus}$
4	Clock (SCK) High or Low Time	$t_{wsck}$	4	—	—	$t_{bus}$
5	Data Setup Time (Inputs)	$t_{su}$	8	—	—	ns
6	Data Hold Time (Inputs)	$t_{hi}$	8	—	—	ns
7	Slave Access Time (time to data active)	$t_a$	—	—	20	ns
8	Slave MISO Disable Time	$t_{dis}$	—	—	22	ns
9	Data Valid after SCK Edge	$t_{vsck}$	—	—	$30 + t_{bus}^1$	ns
10	Data Valid after $\overline{SS}$ fall	$t_{vss}$	—	—	$30 + t_{bus}^1$	ns
11	Data Hold Time (Outputs)	$t_{ho}$	20	—	—	ns
12	Rise and Fall Time Inputs	$t_{rfi}$	—	—	8	ns
13	Rise and Fall Time Outputs	$t_{rfo}$	—	—	8	ns

NOTES:

1.  $t_{bus}$  added due to internal synchronization delay

## A.8 External Bus Timing

A timing diagram of the external multiplexed-bus is illustrated in **Figure A-10** with the actual timing values shown on table **Table A-21**. All major bus signals are included in the diagram. While both a data write and data read cycle are shown, only one or the other would occur on a particular bus cycle.

### A.8.1 General Muxed Bus Timing

The expanded bus timings are highly dependent on the load conditions. The timing parameters shown assume a balanced load across all outputs.

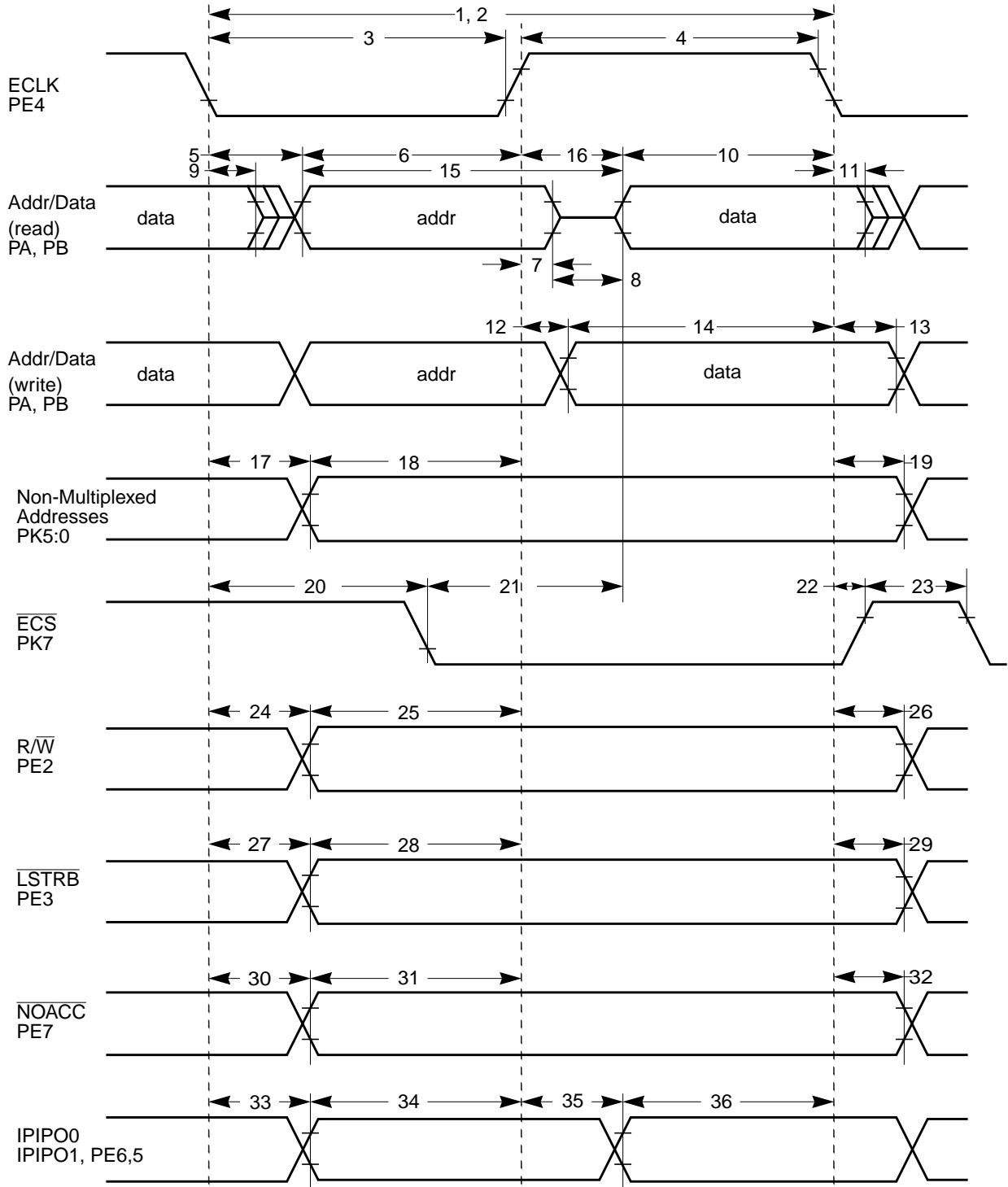

Figure A-10 General External Bus Timing

**Table A-21 Expanded Bus Timing Characteristics**

Conditions are shown in **Table A-4** unless otherwise noted,  $C_{LOAD} = 50\text{pF}$

Num	C	Rating	Symbol	Min	Typ	Max	Unit
1	P	Frequency of operation (E-clock)	$f_o$	0		25.0	MHz
2	P	Cycle time	$t_{cyc}$	40			ns
3	D	Pulse width, E low	$PW_{EL}$	19			ns
4	D	Pulse width, E high <sup>1</sup>	$PW_{EH}$	19			ns
5	D	Address delay time	$t_{AD}$			8	ns
6	D	Address valid time to E rise ( $PW_{EL}-t_{AD}$ )	$t_{AV}$	11			ns
7	D	Muxed address hold time	$t_{MAH}$	2			ns
8	D	Address hold to data valid	$t_{AHDS}$	7			ns
9	D	Data hold to address	$t_{DHA}$	2			ns
10	D	Read data setup time	$t_{DSR}$	13			ns
11	D	Read data hold time	$t_{DHR}$	0			ns
12	D	Write data delay time	$t_{DDW}$			7	ns
13	D	Write data hold time	$t_{DHW}$	2			ns
14	D	Write data setup time <sup>1</sup> ( $PW_{EH}-t_{DDW}$ )	$t_{DSW}$	12			ns
15	D	Address access time <sup>1</sup> ( $t_{cyc}-t_{AD}-t_{DSR}$ )	$t_{ACCA}$	19			ns
16	D	E high access time <sup>1</sup> ( $PW_{EH}-t_{DSR}$ )	$t_{ACCE}$	6			ns
17	D	Non-multiplexed address delay time	$t_{NAD}$			6	ns
18	D	Non-muxed address valid to E rise ( $PW_{EL}-t_{NAD}$ )	$t_{NAV}$	15			ns
19	D	Non-multiplexed address hold time	$t_{NAH}$	2			ns
20	D	Chip select delay time	$t_{CSD}$			16	ns
21	D	Chip select access time <sup>1</sup> ( $t_{cyc}-t_{CSD}-t_{DSR}$ )	$t_{ACCS}$	11			ns
22	D	Chip select hold time	$t_{CSH}$	2			ns
23	D	Chip select negated time	$t_{CSN}$	8			ns
24	D	Read/write delay time	$t_{RWD}$			7	ns
25	D	Read/write valid time to E rise ( $PW_{EL}-t_{RWD}$ )	$t_{RWV}$	14			ns
26	D	Read/write hold time	$t_{RWH}$	2			ns
27	D	Low strobe delay time	$t_{LSD}$			7	ns
28	D	Low strobe valid time to E rise ( $PW_{EL}-t_{LSD}$ )	$t_{LSV}$	14			ns
29	D	Low strobe hold time	$t_{LSH}$	2			ns
30	D	NOACC strobe delay time	$t_{NOD}$			7	ns
31	D	NOACC valid time to E rise ( $PW_{EL}-t_{NOD}$ )	$t_{NOV}$	14			ns

**Table A-21 Expanded Bus Timing Characteristics**

Conditions are shown in <b>Table A-4</b> unless otherwise noted, $C_{LOAD} = 50\text{pF}$							
Num	C	Rating	Symbol	Min	Typ	Max	Unit
32	D	NOACC hold time	$t_{NOH}$	2			ns
33	D	IPIPO[1:0] delay time	$t_{P0D}$	2		7	ns
34	D	IPIPO[1:0] valid time to E rise ( $PW_{EL} - t_{P0D}$ )	$t_{P0V}$	11			ns
35	D	IPIPO[1:0] delay time <sup>1</sup> ( $PW_{EH} - t_{P1V}$ )	$t_{P1D}$	2		25	ns
36	D	IPIPO[1:0] valid time to E fall	$t_{P1V}$	11			ns

## NOTES:

1. Affected by clock stretch: add  $N \times t_{cyc}$  where  $N=0,1,2$  or  $3$ , depending on the number of clock stretches.

## Appendix B Package Information

### B.1 General

This section provides the physical dimensions of the MC9S12DT256 packages.

## B.2 112-pin LQFP package

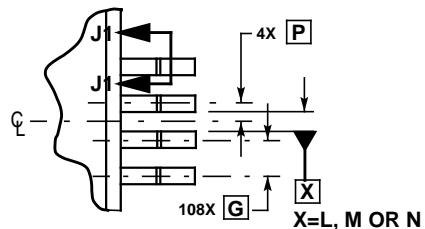
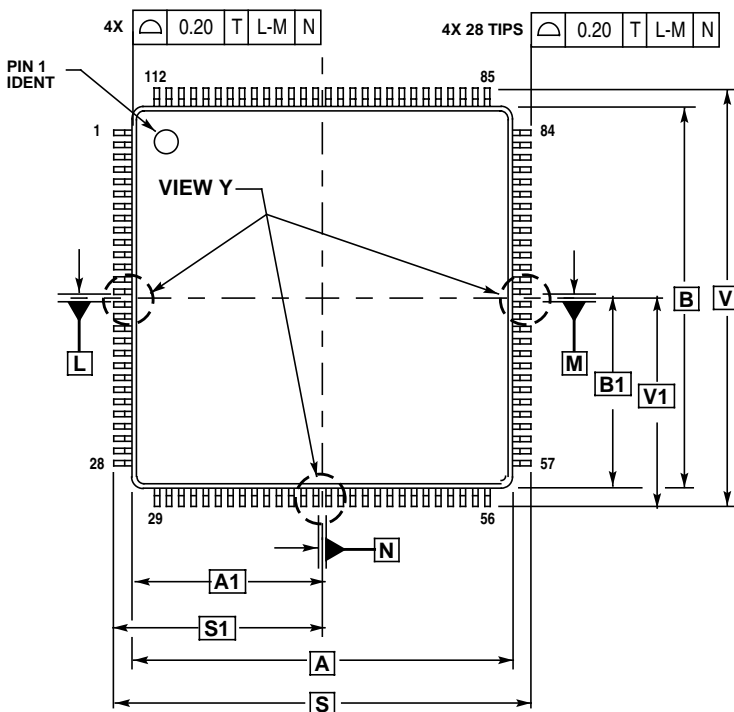

VIEW Y

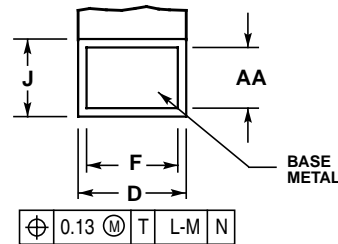

SECTION J1-J1  
ROTATED 90° COUNTERCLOCKWISE

NOTES:

1. DIMENSIONING AND TOLERANCING PER ASME Y14.5M, 1994.
2. DIMENSIONS IN MILLIMETERS.
3. DATUMS L, M AND N TO BE DETERMINED AT SEATING PLANE, DATUM T.
4. DIMENSIONS S AND V TO BE DETERMINED AT SEATING PLANE, DATUM T.
5. DIMENSIONS A AND B DO NOT INCLUDE MOLD PROTRUSION. ALLOWABLE PROTRUSION IS 0.25 PER SIDE. DIMENSIONS A AND B INCLUDE MOLD MISMATCH.
6. DIMENSION D DOES NOT INCLUDE DAMBAR PROTRUSION. ALLOWABLE DAMBAR PROTRUSION SHALL NOT CAUSE THE D DIMENSION TO EXCEED 0.46.

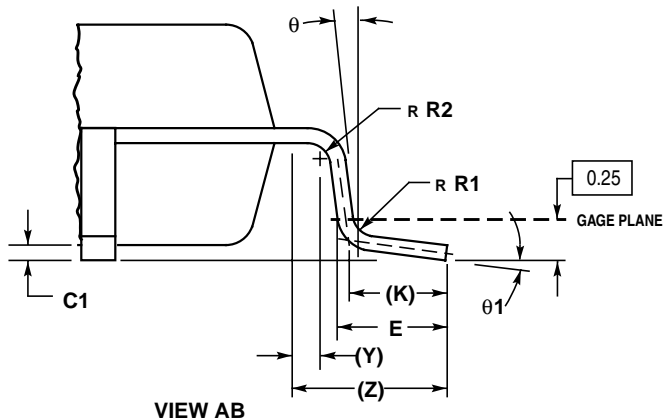
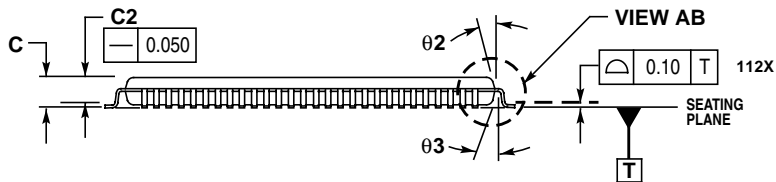

DIM	MILLIMETERS	
	MIN	MAX
A	20.000	BSC
A1	10.000	BSC
B	20.000	BSC
B1	10.000	BSC
C	---	1.600
C1	0.050	0.150
C2	1.350	1.450
D	0.270	0.370
E	0.450	0.750
F	0.270	0.330
G	0.650	BSC
J	0.090	0.170
K	0.500	REF
P	0.325	BSC
R1	0.100	0.200
R2	0.100	0.200
S	22.000	BSC
S1	11.000	BSC
V	22.000	BSC
V1	11.000	BSC
Y	0.250	REF
Z	1.000	REF
AA	0.090	0.160
theta	0°	8°
theta 1	3°	7°
theta 2	11°	13°
theta 3	11°	13°

Figure B-1 112-pin LQFP mechanical dimensions (case no. 987)



### B.3 80-pin QFP package

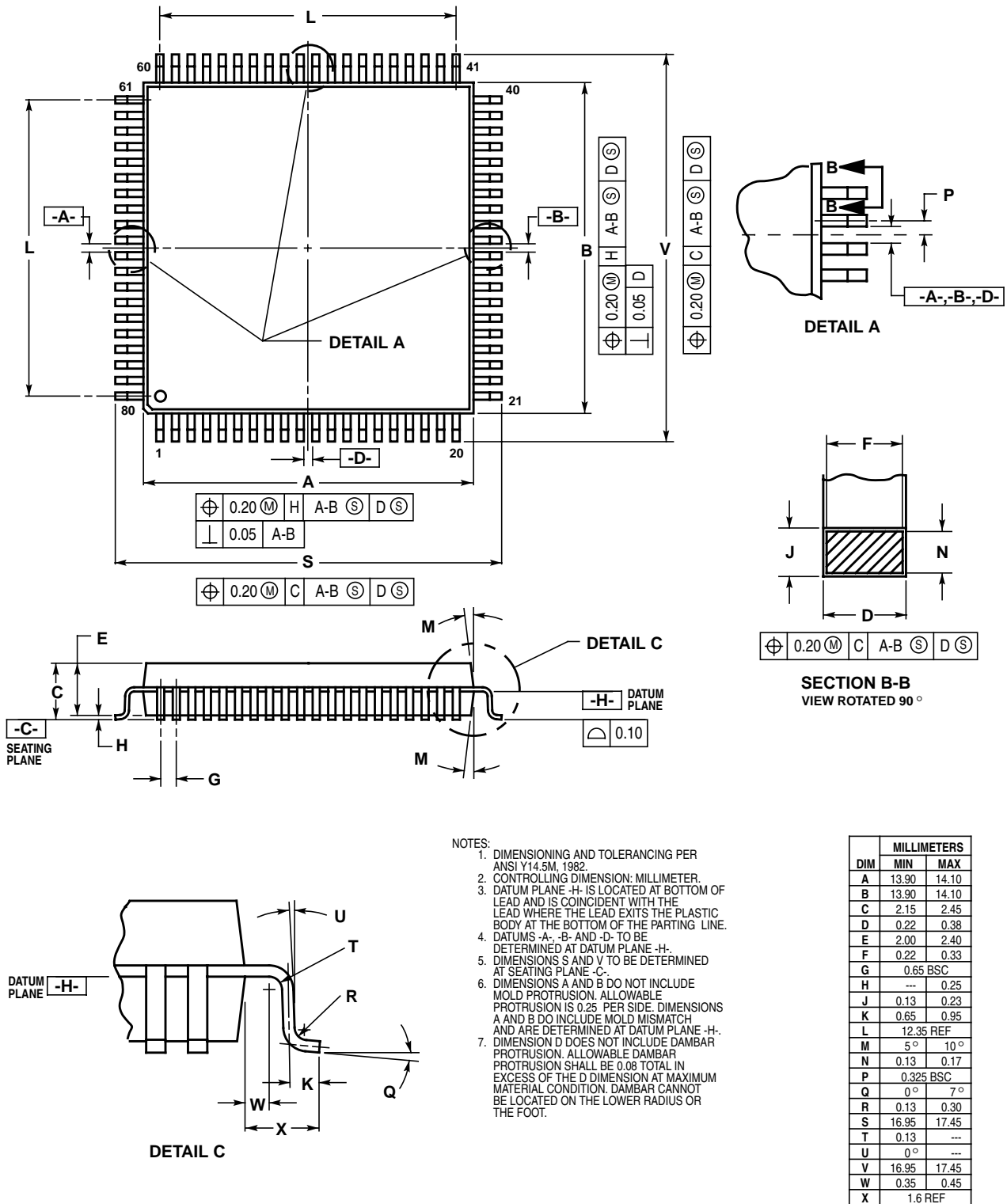

Figure B-2 80-pin QFP Mechanical Dimensions (case no. 841B)



# User Guide End Sheet

**FINAL PAGE OF  
132  
PAGES**