

Specification: (Ta=35°C)	Code:	Description:
Heat transfer, cold side:	A	Air
Heat transfer, warm side:	A	Air
Cascade:	-	
Cooling power: [W]	180	Calculated 180 W at dT=0°C. Tolerance: ±10%.
Voltage, nominal: [VDC]	24	24 VDC
TEM Voltage: [VDC]		Nominal: 24 VDC, Max: 30 VDC
TEM Current: [A]		Nominal: 9.9 A, Initial: 13.1 A, All at dT=0°C. Tolerance: ±10%.
Fans, cold side:	2	L10: 50,000 hrs. at 25°C. Nominal current: 0.25 A. Voltage: 24 VDC ±10%. Max ripple = 3 %
Fans, warm side:	4	L10: 70,000 hrs. at 40°C. Nominal current: 0.48 A. Voltage range 16-30 VDC IP54. Max ripple = 3 %
Temperature controller, sensor:	0	None.
Temperature control settings, trim options:	0	-
Additional controller information:		-
Temperature control position:	1	Power input connector on cold side fan bracket.
Options:	0	-
Overheating thermostat:		75°C ±5°C. Internally on hot side heat sink surface.
Operating temperature:		-10°C to +56°C
TE-Module temperature specification:		Max. surface temperature: 80°C.
Enclosed:		-
Packing:		Individual cardboard box.

General tolerances: SS-ISO 2768-1 v	First angle projection:	Dimension units: Metric: [mm]
--	----------------------------	----------------------------------

Comment / Deviations: Warm side of unit designed to comply with IP54. Hi-Pot tested 750VDC.					
Designed by: A. Kim	Checked by: S. Winberg	Approved by: C. Johansson	Release date: 2011-10-18	Project: Standard	Customer:
Laird Technologies S-43153 Molndal, Sweden tfn: +46 31 420530, fax: +46 31 247909 e-mail: info@lairdtech.com Web: www.lairdtech.com			Title: TE ASSEMBLY AIR-AIR200, 24VDC		
Part nr: AA-200-24-24-00-10			Rev: 06	Version:	Scale: Size, sheet 1:2 A3, 1/4

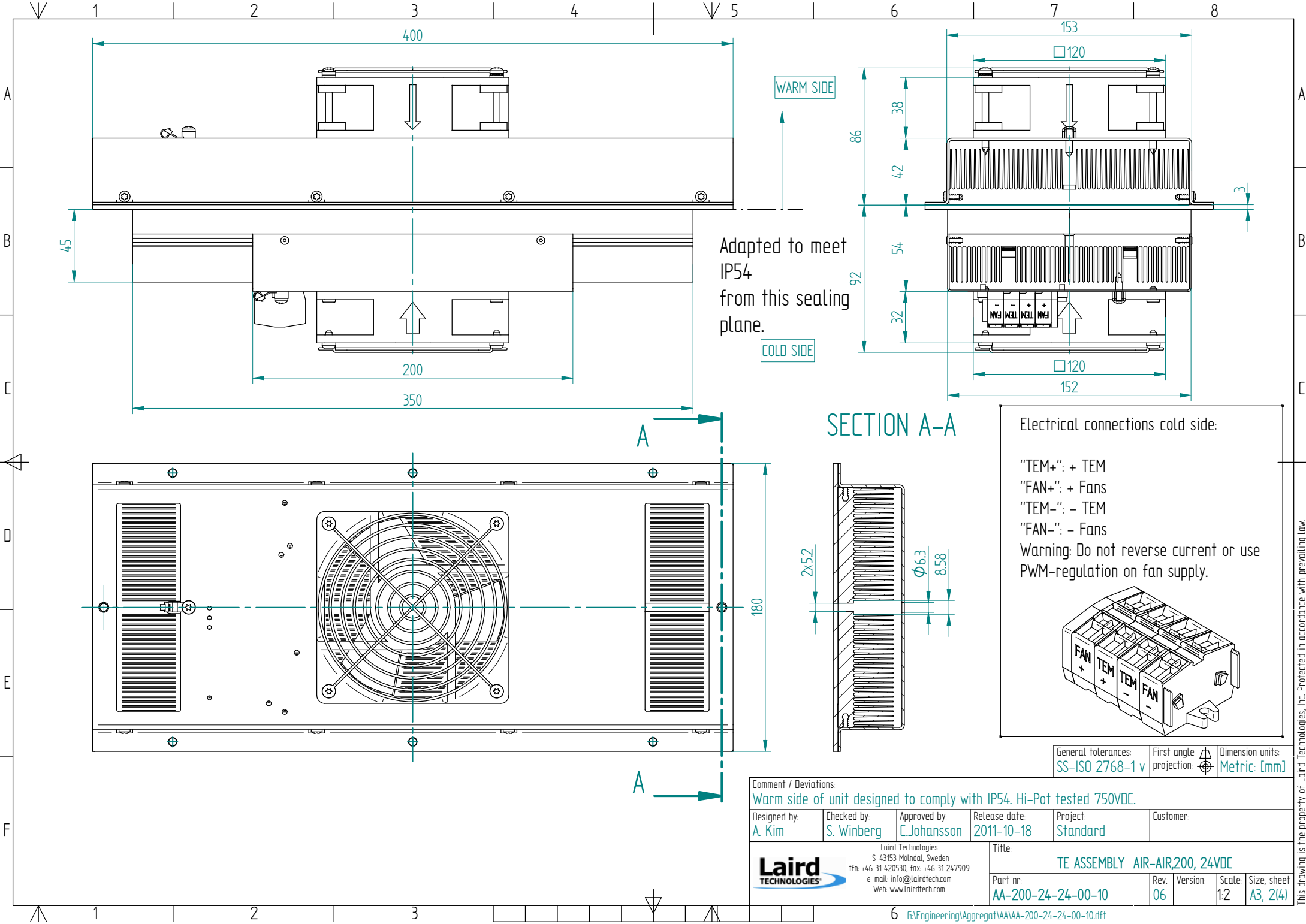

Adapted to meet IP54 from this sealing plane.

SECTION A-A

Electrical connections cold side:

- "TEM+": + TEM
- "FAN+": + Fans
- "TEM-": - TEM
- "FAN-": - Fans

Warning: Do not reverse current or use PWM-regulation on fan supply.

General tolerances: SS-ISO 2768-1 v
 First angle projection: Dimension units: Metric: [mm]

Comment / Deviations: Warm side of unit designed to comply with IP54. Hi-Pot tested 750VDC.					
Designed by: A. Kim	Checked by: S. Winberg	Approved by: C. Johansson	Release date: 2011-10-18	Project: Standard	Customer:
Laird Technologies S-43153 Molndal, Sweden tfn +46 31 420530, fax: +46 31 247909 e-mail: info@lairdtech.com Web: www.lairdtech.com			Title: TE ASSEMBLY AIR-AIR200, 24VDC		
Part nr: AA-200-24-24-00-10			Rev: 06	Version:	Scale: Size, sheet 1:2 A3, 2(4)

Thermoelectric AIR conditioner - AA-200-24-24-00-10

2x ϕ 5.2
(2 holes to mount the unit (optional).)

6x ϕ 5.5
(6 holes used to mount the unit.)

Installation and Service manual

Installation:

1. The TE assembly is mounted in a cabinet with "Warm sidemounted externally.
2. Suitable cabinet cutout is 155x352 mm.
3. Recommended for general purposes: the TE assembly is fastened with 8xM5 machine screws, 8x M5 flat washers, 8x M5 tooth washers and 8x M5 nuts so that the gasket material will seal off around the flange of the assembly.
4. **The TE assembly must be positioned in vertical direction (heat sink fins in vertical direction).**
5. The TE assembly must be protected from external force or violence.
6. Fuse should be placed on the incoming wires by the customer. 20 A, Fast acting or Very Fast Acting, enhanced breaking capacity. The fuse should withstand 1.3xIn for a minimum of 60 seconds. External fuse must protect the input power lines.

Service:

Fan impellers and heat sinks must be cleaned on regular intervals to reduce risk for overheating and reduction of cooling function. The interval may vary depending on environment.

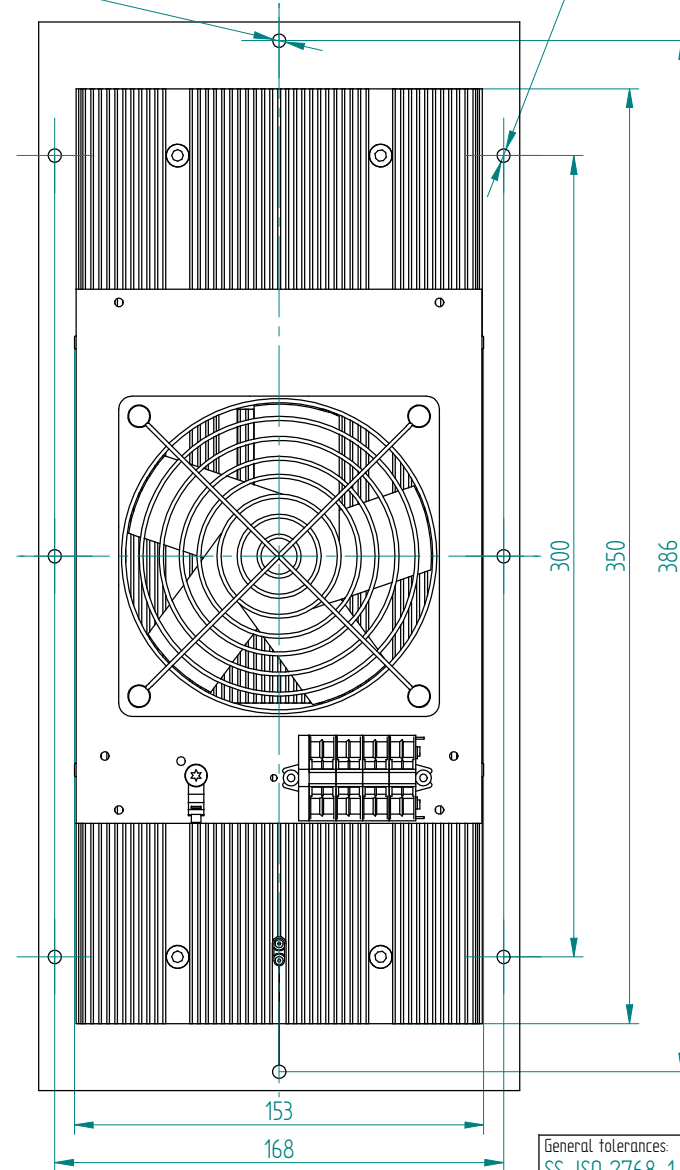
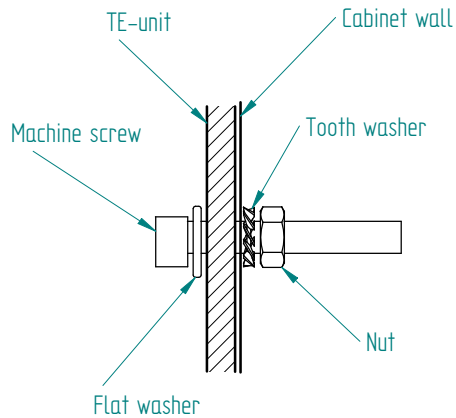

General tolerances: SS-ISO 2768-1 v	First angle projection: 	Dimension units: Metric: [mm]
--	-----------------------------	----------------------------------

Comment / Deviations: Warm side of unit designed to comply with IP54. Hi-Pot tested 750VDC.					
Designed by: A. Kim	Checked by: S. Winberg	Approved by: C. Johansson	Release date: 2011-10-18	Project: Standard	Customer:
Laird Technologies S-43153 Molndal, Sweden tfn +46 31 420530, fax +46 31 247909 e-mail: info@lairdtech.com Web: www.lairdtech.com			Title: TE ASSEMBLY AIR-AIR200, 24VDC		
Part nr: AA-200-24-24-00-10			Rev: 06	Version:	Scale: Size, sheet 1:2 A3, 3(4)