

KMT37 Angular Sensor



- AMR Sensor with 180° period
- For the use at moderate field strengths
- High accuracy
- Reliable SO8-package
- Qualified for automotive applications

DESCRIPTION

The KMT37 is a magnetic field sensor based on the anisotropic magneto resistance effect, i.e. it is sensing the **magnetic field direction** independently on the magnetic field strength for applied field strengths $H \geq 14$ kA/m. The sensor contains two parallel supplied Wheatstone bridges, which enclose a sensitive angle of 45 degrees.

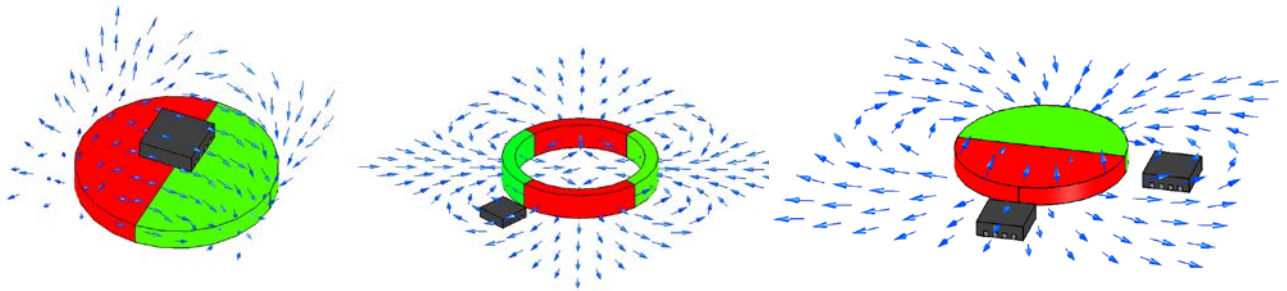

A rotating magnetic field in the surface parallel to the chip (x-y plane) will deliver two independent sinusoidal output signals, one following a $\cos(2\alpha)$ and the second following a $\sin(2\alpha)$ function, α being the angle between sensor and field direction (see Figure 2).

FEATURES

- Contactless angular position
- Design optimized linearity
- High accuracy
- Low cost, low power
- Self diagnosis feature
- User has complete control over signal evaluation
- Reliable SO8-Package
- High rotational speed possible
- Extended operating temperature range (-40 °C to +150 °C)
- Ideal for harsh environments due to magnetic sensing principle
- RoHS compliant (lead free)

APPLICATIONS

- Absolute and incremental angle measurement
- Motor motion control
- Robotics
- Camera positioning
- Potentiometer replacement
- Position measurement in medical applications
- Automotive (steering angle, torque, etc.)

KMT37 Angular Sensor

CHARACTERISTIC VALUES

Parameter	Condition	Symbol	Min	Typ	Max	Unit
Absolute maximum ratings						
Supply voltage		V_{CC}			10	V
Operating temperature		T_{OP}	-40		+150	°C
Storage temperature		T_{ST}	-50		+150	°C
Operating conditions						
Supply voltage		V_{CC}	0	5	8.5	V
Applied magnetic field		H	14	25	400	kA/m
General parameters						
Bridge resistance	T = 25 °C	R_B	2.4	3.0	3.6	k Ω
max. signal amplitude	T = 25 °C, H = 25 kA/m	$\Delta V/V_{CC}$	9	11	13	mV/V
Offset voltage 2)	T = 25 °C, H = 25 kA/m	V_{OFF}/V_{CC}	-1		+1	mV/V
Hysteresis 1) (Repeatability)	H = 14 kA/m H = 25 kA/m	Hyst		0.1 0.05	0.4 0.1	deg
Accuracy 1)	H = 14 kA/m H = 25 kA/m	$\Delta\alpha$		0.1 0.05	0.5 0.15	deg
TC of amplitude	H = 25 kA/m, 3)	TC_{SV}	-0.4	-0.35	-0.3	%/K
TC of bridge resistance	3)	TC_{BR}	+0.3	+0.35	+0.4	%/K
TC of offset voltage	H = 25 kA/m, 1), 2)	TC_{Voff}	-4	0	+4	$\mu V/V/K$
Amplitude synchronism	H = 25 kA/m, 4)	k	99.5	100	100.5	%
Sensitivity (zero crossing)	H = 25 kA/m, 4), $\alpha_1 = 135^\circ$, $\alpha_2 = 0^\circ$	$S_{\alpha 1}$ or $S_{\alpha 2}$	$\Delta V_n/V_{CC} [mV/V] \times \pi / 180^\circ$			mV/V/deg
Peak output voltage	H = 25 kA/m, $V_{CC} = 5$ V, 4)	V_{poN}	45	55	65	mV/V

- 1) Hysteresis and accuracy are depending nearly inversely proportional on the magnetic field strength. The accuracy is defined as the max. angular difference between actual field angle and measured angle calculated from the third and fifth harmonics of the Fourier spectrum. The hysteresis is defined as angular difference between left and right turn.
- 2) Offset voltages are calculated by measuring both output voltages at several field angles between 0 and 360°, then drawing a diagram with the output voltages as axis and fitting a circle to the signal points. The Offsets are the coordinates of the circle center.
- 3) Reference temperature (Temp. with parameter value = 100%) $T_{ref} = -25$ °C, calculated from values at -25°C and +125 °C.
- 4) This parameter is given for reference only and is not measured on a regular basis.

KMT37 Angular Sensor

BLOCK DIAGRAM

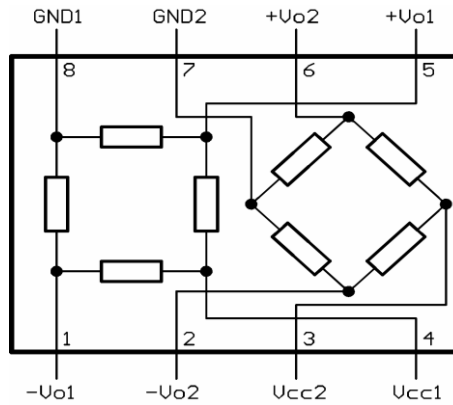

Figure 1: internal and external connections

TYPICAL PERFORMANCE CURVES

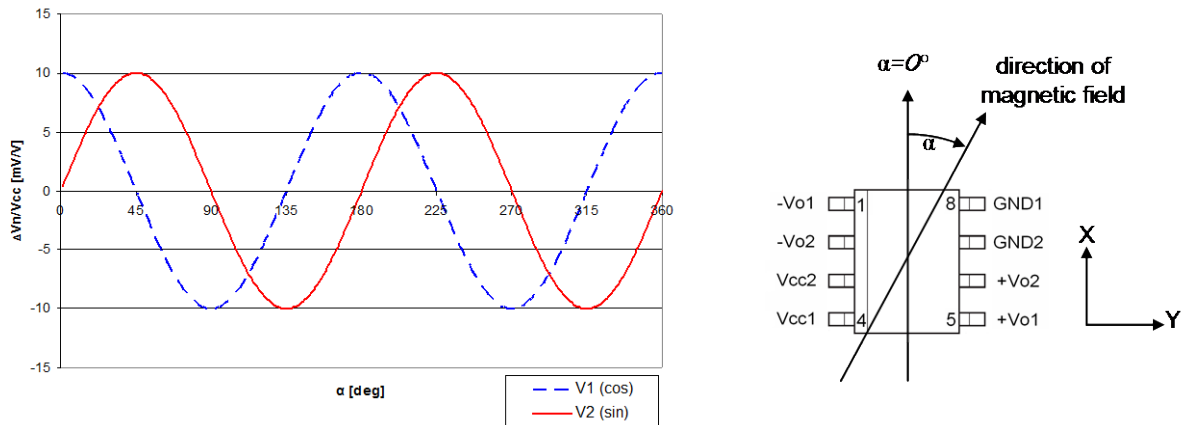
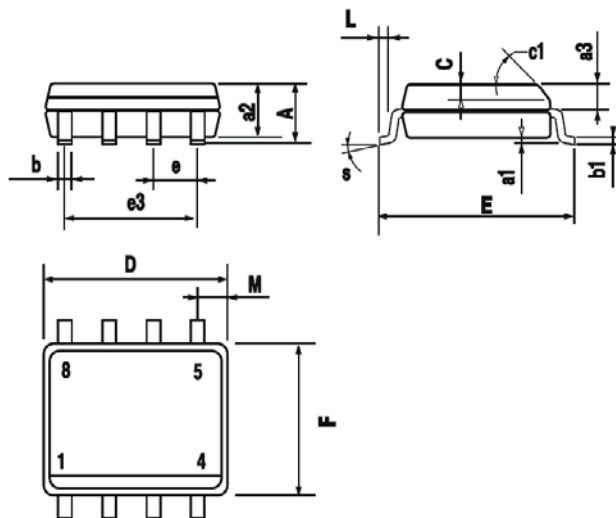

Figure 2: Characteristic curves for KMT37

KMT37 Angular Sensor

SENSOR OUTLINE



DIM.	mm			inch		
	MIN.	TYP.	MAX.	MIN.	TYP.	MAX.
A			1.75			0.069
a1	0.1		0.25	0.004		0.010
a2			1.65			0.065
a3	0.65		0.85	0.026		0.033
b	0.35		0.48	0.014		0.019
b1	0.19		0.25	0.007		0.010
C	0.25		0.5	0.010		0.020
c1	45° (typ.)					
D (1)	4.8		5.0	0.189		0.197
E	5.8		6.2	0.228		0.244
e		1.27			0.050	
e3		3.81			0.150	
F (1)	3.8		4.0	0.150		0.157
L	0.4		1.27	0.016		0.050
M			0.6			0.024
S	8° (max.)					

Figure 3: SO8-Package

PIN ASSIGNMENT

Pin	Symbol	Function
1	$-V_{o1}$	negative output bridge 1
2	$-V_{o2}$	negative output bridge 2
3	V_{cc2}	positive supply voltage bridge 2
4	V_{cc1}	positive supply voltage bridge 1
5	$+V_{o1}$	positive output bridge 1
6	$+V_{o2}$	positive output bridge 2
7	GND_2	negative supply voltage bridge 2
8	GND_1	negative supply voltage bridge 1

SOLDER PROFILE

Recommended solder reflow process according to IPC/JEDEC J-STD-020D (Pb-Free Process)

KMT37 Angular Sensor

ORDERING CODE

DEVICE	DELIVERY FORM	MOQ	PART NUMBER
KMT37	TnR	1 Reel (2500 pcs.)	G-MRCO-037
KMT37	Tube	1 Tube	on request

ORDERING INFORMATION

NORTH AMERICA	EUROPE	ASIA
Measurement Specialties, Inc. 1000 Lucas Way Hampton, VA 23666 United States Phone: +1-800-745-8008 Fax: +1-757-766-4297 Email: sales@meas-spec.com Web: www.meas-spec.com	MEAS Deutschland GmbH Hauert 13 D-44227 Dortmund Germany Phone: +49-(0)231-9740-0 Fax: +49-(0)231-9740-20 Email: info.de@meas-spec.com Web: www.meas-spec.com	Measurement Specialties China Ltd. No. 26, Langshan Road High-tech Park (North) Nanshan District, Shenzhen 518057 China Phone: +86-755-33305088 Fax: +86-755-33305099 Email: info.cn@meas-spec.com Web: www.meas-spec.com

The information in this sheet has been carefully reviewed and is believed to be accurate; however, no responsibility is assumed for inaccuracies. Furthermore, this information does not convey to the purchaser of such devices any license under the patent rights to the manufacturer. Measurement Specialties, Inc. reserves the right to make changes without further notice to any product herein. Measurement Specialties, Inc. makes no warranty, representation or guarantee regarding the suitability of its product for any particular purpose, nor does Measurement Specialties, Inc. assume any liability arising out of the application or use of any product or circuit and specifically disclaims any and all liability, including without limitation consequential or incidental damages. Typical parameters can and do vary in different applications. All operating parameters must be validated for each customer application by customer's technical experts. Measurement Specialties, Inc. does not convey any license under its patent rights nor the rights of others.