

## High voltage high-side driver

### Features

- High voltage rail up to 160 V
- dV/dt immunity  $\pm 50$  V/nsec in full temperature range
- Driver current capability:  
500 mA source,  
500 mA sink
- Switching times 100 ns rise/fall with 2.5 nF load
- CMOS/TTL Schmitt trigger inputs with hysteresis
- Under voltage lock out
- Clamping on  $V_{CC}$
- Loading circuit for external Bootstrap capacitor
- Inverting input
- Reset circuitry
- SO-8 package

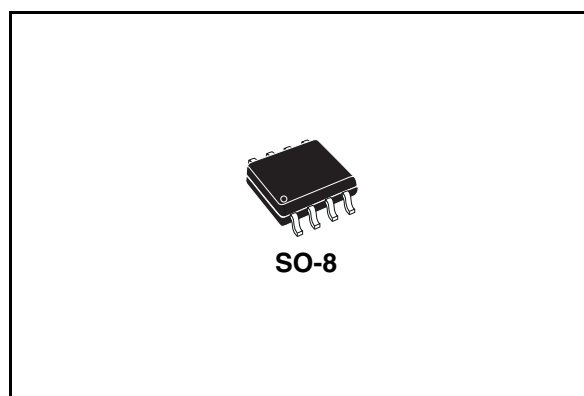

### Description

The L9856 is an high voltage device, manufactured with the BCD "OFF-LINE" technology.

It has the capability of driving N-Channel Power MOS transistors. The upper (floating) section is enabled to work with voltage rail up to 160 V. The logic Inputs are CMOS/TTL compatible for ease of interfacing with controlling devices.

**Table 1. Device summary**

Order code	Operating temp range, °C	Package	Packing
L9856	-40 to +125	SO-8	Tube
L9856TR	-40 to +125	SO-8	Tape and Reel

# Contents

- 1      Block diagram and pin description ..... 5**
  - 1.1    Block diagram ..... 5
  - 1.2    Pin description ..... 5
  
- 2      Electrical specifications ..... 6**
  - 2.1    Thermal data ..... 6
  - 2.2    Absolute maximum ratings ..... 6
  - 2.3    Recommended operating conditions ..... 7
  - 2.4    Electrical characteristics ..... 7
  - 2.5    Logic table ..... 10
  
- 3      Timing diagrams ..... 11**
  
- 4      Package information ..... 12**
  
- 5      Revision history ..... 13**

## List of tables

Table 1.	Device summary . . . . .	1
Table 2.	Pin function . . . . .	5
Table 3.	Thermal data . . . . .	6
Table 4.	Absolute maximum ratings . . . . .	6
Table 5.	Recommended operating conditions . . . . .	7
Table 6.	Electrical characteristics . . . . .	7
Table 7.	Logic table . . . . .	10
Table 8.	Document revision history . . . . .	13

## List of figures

Figure 1.	Block diagram . . . . .	5
Figure 2.	Pin connection (top view) . . . . .	5
Figure 3.	Input/output timing diagram . . . . .	11
Figure 4.	Reset timing diagram . . . . .	11
Figure 5.	SO-8 mechanical data and package dimensions . . . . .	12

# 1 Block diagram and pin description

## 1.1 Block diagram

Figure 1. Block diagram

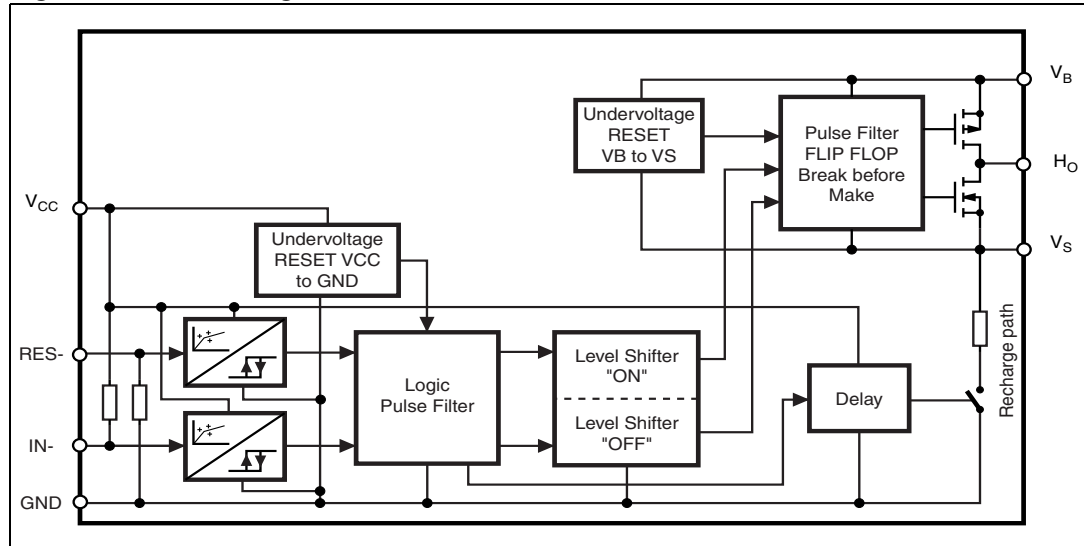

## 1.2 Pin description

Figure 2. Pin connection (top view)

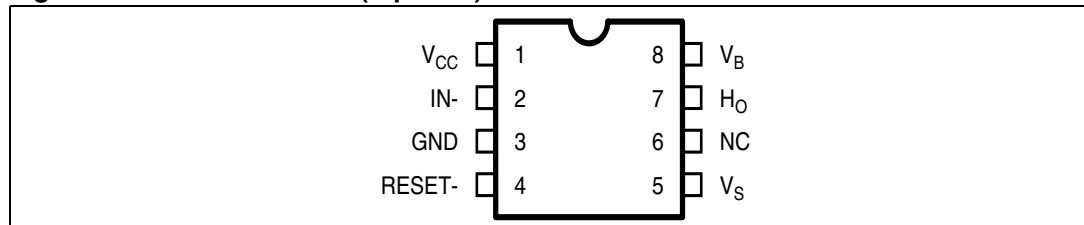

Table 2. Pin function

Pin #	Pin name	Description
1	$V_{CC}$	Driver supply, typical 5V
2	$IN-$	Driver control signal input (negative logic)
3	$GND$	Ground
4	$RESET-$	Driver enable signal input (negative logic)
5	$V_S$	MOSFET source connection
6	$NC$	No connection (no bondwire)
7	$H_O$	MOSFET gate connection
8	$V_B$	Driver output stage supply

## 2 Electrical specifications

### 2.1 Thermal data

Table 3. Thermal data

Symbol	Parameter	Value	Unit
$R_{th(j-amb)}$	Thermal resistance junction to ambient	Max. 150	°C/W

### 2.2 Absolute maximum ratings

Absolute maximum ratings indicate sustained limits beyond which damage to the device may occur. All voltage parameters are absolute voltages referenced to GND, all currents are defined positive into any lead. An operation above the absolute maximum limit is not implied and can damage the part.

Table 4. Absolute maximum ratings

Symbol	Parameter	Value		Units
		Min.	Max.	
$V_{BS}$	High side floating supply voltage.	-0.3	20	V
$V_B$	High side driver output stage voltage neg. transient: 0.5 ms, external MOSFET off.	-5	166	V
$V_S$	High side floating supply offset voltage neg. transient 0.1 $\mu$ s, repetitive pulse over lifetime at every switching event.	-8	150	V
$V_{HO}$	Output voltage gate connection.	$V_S - 0.3$	$V_B + 0.3$	V
$V_{CC}$	Supply voltage.	-0.3	20	V
$V_{IN}$	Input voltage.	-0.3	$V_{CC} + 0.3$	V
$I_{IN}$	Input injection current. Full function, no latch-up; (guaranteed by design). Test at 5 V and 7 V on Eng. Samples.	---	+1	mA
$V_{RES}$	Reset input voltage.	-0.3	$V_{CC} + 0.3$	V
$V_{esd}$	Electrostatic discharge voltage (human body model).	2k		V
$V_{CDM}$	Charge device model CDM, EOS/ESD Ass. Std 5.3. Number of discharges per pin: 6.	500		V
dV/dt	Allowable offset voltage slew rate.	-50	50	V/nsec
$T_J$	Junction temperature.	-55	150	°C
$T_{stg}$	Storage temperature.	-55	150	
$T_L$	Lead temperature (Soldering, 10 seconds) 3 times Bosch soldering profile acc. to Bosch soldering conditions, Gen. Spec.	-	300	

## 2.3 Recommended operating conditions

For proper operations the device should be used within the recommended conditions.

**Table 5. Recommended operating conditions**

Symbol	Parameter	Value		Units
		Min.	Max.	
$V_B^{(1)}$	High side driver output stage voltage	VS+4.4	VS+18	V
$V_S$	High side floating supply offset voltage (25°C) (125°C)	-3.2 -2.9	150 150	V
$V_{HO}$	Output voltage gate connection	$V_S$	$V_B$	V
$V_{CC}$	Supply voltage	4.4	6.5	V
$V_{IN}$	Input voltage	0	$V_{CC}$	V
$V_{RES}$	Reset input voltage	0	$V_{CC}$	V
$dV/dt^{(2)}$	Allowable offset voltage slew rate	-50	50	V/nsec
$F_S$	Switching frequency		200	kHz

1. Reset-Logic functional for  $V_{BS} > 2V$ , independent from  $V_{CC}$ -level.

2. Guaranteed by design.

## 2.4 Electrical characteristics

**Table 6. Electrical characteristics**

Unless otherwise specified,  $V_{CC} = 5 V$ ,  $V_{BS} = 7 V$ ,  $V_S = 0 V$ ,  $IN = 0 V$ ,  $RES = 5 V$ , load  $R = 50 \Omega$ ,  $C = 2.5 nF$ . Unless otherwise noted, these specifications apply for an operating ambient temperature range of  $-40 \text{ }^\circ\text{C} < T_{amb} < 125 \text{ }^\circ\text{C}$ .

Symbol	Parameter	Test condition	Min.	Typ.	Max.	Unit
<b><math>V_{CC}</math> supply</b>						
$V_{CCUV+}$	$V_{CC}$ supply undervoltage positive going threshold	$V_{CC}$ rising from 0 V			4.3	V
$V_{CCUV-}$	$V_{CC}$ supply undervoltage negative going threshold	$V_{CC}$ dropping from 5 V	2.8			
$V_{CCUVHYS}$	$V_{CC}$ supply undervoltage lockout hysteresis		0.02	0.3	0.6	
$td_{UVCC}$	Undervoltage lockout response time	$V_{CC}$ steps either from 6.5 V to 2.7 V or from 2.7 V to 6.5 V	0.5		20	$\mu\text{s}$
$I_{OCC}$	$V_{CC}$ supply current				400	$\mu\text{A}$

**Table 6. Electrical characteristics (continued)**

Unless otherwise specified,  $V_{CC} = 5\text{ V}$ ,  $V_{BS} = 7\text{ V}$ ,  $V_S = 0\text{ V}$ ,  $I_N = 0\text{ V}$ ,  $R_{ES} = 5\text{ V}$ , load  $R = 50\ \Omega$ ,  $C = 2.5\text{ nF}$ . Unless otherwise noted, these specifications apply for an operating ambient temperature range of  $-40\text{ }^\circ\text{C} < T_{amb} < 125\text{ }^\circ\text{C}$ .

Symbol	Parameter	Test condition	Min.	Typ.	Max.	Unit
<b><math>V_{BS}</math> supply</b>						
$V_{BSUV+}$	$V_{BS}$ supply undervoltage positive going threshold	$V_{CC}$ rising from 0 V			4.3	V
$V_{BSUV-}$	$V_{BS}$ supply undervoltage negative going threshold	$V_{CC}$ dropping from 5 V	2.8			V
$V_{BSUVHYS}$	$V_{BS}$ supply undervoltage lockout hysteresis		0.02	0.3	0.4	
$t_{dUVBS}$	Undervoltage lockout response time	$V_{BS}$ steps either from 6.5 V to 2.7 V or from 2.7 V to 6.5V	0.5		20	$\mu\text{s}$
$I_{QBS1}$	$V_{BS}$ supply current	static mode, $I_N = 0\text{ V}$ or 5 V			100	$\mu\text{A}$
$I_{QBS2}$		static mode, $V_{BS} = 16\text{ V}$ , $I_N = 0\text{ V}$ or 5 V			200	$\mu\text{A}$
$\Delta V_{BS}$	$V_{BS}$ drop due to output turn-on	$C_{BS} = 1\ \mu\text{F}$ , $t_{dIG-IN} = 3\ \mu\text{s}$ , $t_{TEST} = 100\ \mu\text{s}$			210	mV
<b>Gate driver characteristics</b>						
$I_{PKS01}$	Peak output source current	$T_j = 25\text{ }^\circ\text{C}$	120	250		mA
$I_{PKS02}$			70	150		
$I_{PKS03}$		$V_{BS} = 16\text{ V}$ , $T_j = 25\text{ }^\circ\text{C}$	250	500		
$I_{PKS04}$		$V_{BS} = 16\text{ V}$	150	300		
$I_{HO,off}$	HO off state leakage current	guaranteed by design			1	$\mu\text{A}$
$t_{r1}$	Output rise time	$T_j = 25\text{ }^\circ\text{C}$		0.2	0.4	$\mu\text{s}$
$t_{r2}$				0.3	0.5	
$t_{r3}$		$V_{BS} = 16\text{ V}$ , $T_j = 25\text{ }^\circ\text{C}$		0.1	0.2	
$t_{r4}$		$V_{BS} = 16\text{ V}$		0.15	0.3	
$I_{PKSi1}$	Peak output sink current	$I_N = 5\text{ V}$ , $T_j = 25\text{ }^\circ\text{C}$	120	250		mA
$I_{PKSi2}$		$I_N = 5\text{ V}$	70	150		
$I_{PKSi3}$		$I_N = 5\text{ V}$ , $T_j = 25\text{ }^\circ\text{C}$ $V_{BS} = 16\text{ V}$	250	500		
$I_{PKSi4}$		$I_N = 5\text{ V}$ , $V_{BS} = 16\text{ V}$	150	300		
$t_{f1}$	Output fall time	$I_N = 5\text{ V}$ , $T_j = 25\text{ }^\circ\text{C}$		0.2	0.4	$\mu\text{s}$
$t_{f2}$		$I_N = 5\text{ V}$ ,		0.3	0.5	
$t_{f3}$		$V_{BS} = 16\text{ V}$ , $I_N = 5\text{ V}$ , $T_j = 25\text{ }^\circ\text{C}$		0.1	0.2	
$t_{f4}$		$V_{BS} = 16\text{ V}$ , $I_N = 5\text{ V}$ ,		0.15	0.3	



**Table 6. Electrical characteristics (continued)**

Unless otherwise specified,  $V_{CC} = 5\text{ V}$ ,  $V_{BS} = 7\text{ V}$ ,  $V_S = 0\text{ V}$ ,  $I_N = 0\text{ V}$ ,  $R_{ES} = 5\text{ V}$ , load  $R = 50\ \Omega$ ,  $C = 2.5\text{ nF}$ . Unless otherwise noted, these specifications apply for an operating ambient temperature range of  $-40\text{ }^\circ\text{C} < T_{amb} < 125\text{ }^\circ\text{C}$ .

Symbol	Parameter	Test condition	Min.	Typ.	Max.	Unit
$t_{plhi}$	Input-to-output turn-on propagation delay (50 % input level to 10 % output level)			0.1	0.35	$\mu\text{s}$
$t_{phli}$	Input-to-output turn-off propagation delay (50 % input level to 90 % output level)			0.1	0.4	
$t_{plhr}$	RES-to-output turn-on propagation delay (50 % input level to 10% output level)			0.1	0.4	
$t_{phlr}$	RES-to-output turn-off propagation delay (50 % input level to 90 % output level)			0.1	0.4	
<b>Input characteristics</b>						
$V_{INH}$	High logic level input threshold	$V_{CC} = 5\text{ V}$	0.6 $V_{CC}$			V
$V_{INL}$	Low logic level input threshold				0.28 $V_{CC}$	
$R_{IN}$	High logic level input resistance		60	100	250	$k\Omega$
$I_{IN}$	High logic level input current	$V_{IN} = V_{CC}$			5	$\mu\text{A}$
$V_{RESH}$	High logic level RES input threshold	$V_{CC} = 5\text{ V}$	0.6 $V_{CC}$			
$V_{RESL}$	Low logic level RES input threshold					0.28 $V_{CC}$
$R_{RES}$	High logic level RES Input resistance		60	100	250	$k\Omega$
$I_{RES}$	Low logic level input current	$V_{RES} = 0$			5	$\mu\text{A}$
<b>Recharge characteristics</b>						
$t_{on\_rech}$	Recharge transistor turn-on propagation delay	$V_S = 5\text{ V}$	3	6	9	$\mu\text{s}$
$t_{off\_rech}$	Recharge transistor turn-off propagation delay			0.1	0.5	$\mu\text{s}$
$V_{RECH}$	Recharge output transistor on-state voltage drop	1 mA forced on recharge path on	0.5		1.2	V
<b>Deadtime characteristics</b>						
$DT_{HOFF}$	High side turn-off to recharge gate turn-on	$V_{CC} = 5\text{ V}$	3	6	9	$\mu\text{s}$
$DT_{HON}$	Recharge gate turn-off to high side turn-on			0.1	0.4	

## 2.5 Logic table

Table 7. Logic table

Supply voltages and thresholds		Signals		Output Ho	Recharge path
V <sub>CC</sub>	V <sub>BS</sub>	RESET-	IN-		
< V <sub>CCUV-</sub>	X	X	X	OFF	ON
X	X	LOW	X	OFF	ON
X	X	X	HIGH	OFF	ON
> V <sub>CCUV+</sub>	> V <sub>BSUV+</sub>	HIGH	LOW	ON	OFF
> V <sub>CCUV+</sub>	< V <sub>BSUV-</sub>	HIGH	LOW	OFF	OFF

Note: X means independent from signal.

### 3 Timing diagrams

Figure 3. Input/output timing diagram

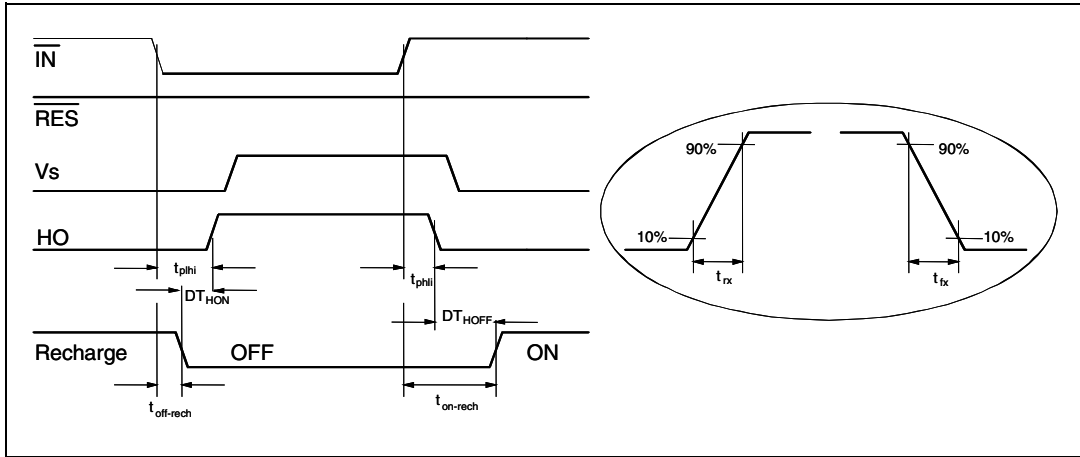
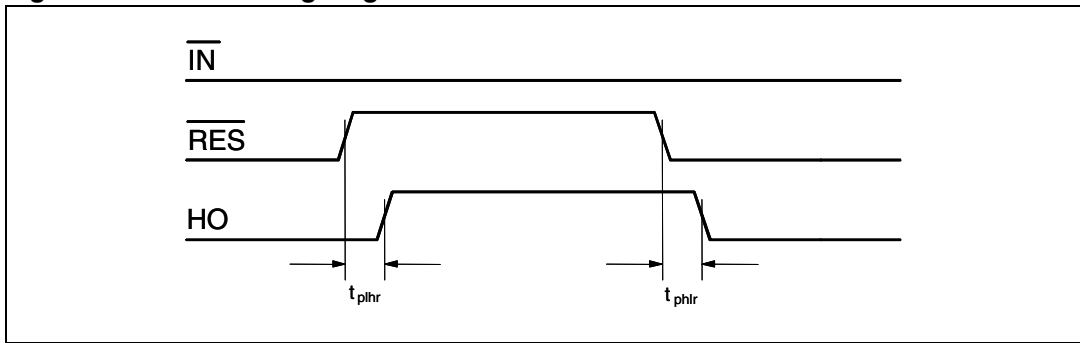

Figure 4. Reset timing diagram



# 4 Package information

In order to meet environmental requirements, ST (also) offers these devices in ECOPACK® packages. ECOPACK® packages are lead-free. The category of second Level Interconnect is marked on the package and on the inner box label, in compliance with JEDEC Standard JESD97. The maximum ratings related to soldering conditions are also marked on the inner box label.

ECOPACK is an ST trademark. ECOPACK specifications are available at: [www.st.com](http://www.st.com).

**Figure 5. SO-8 mechanical data and package dimensions**

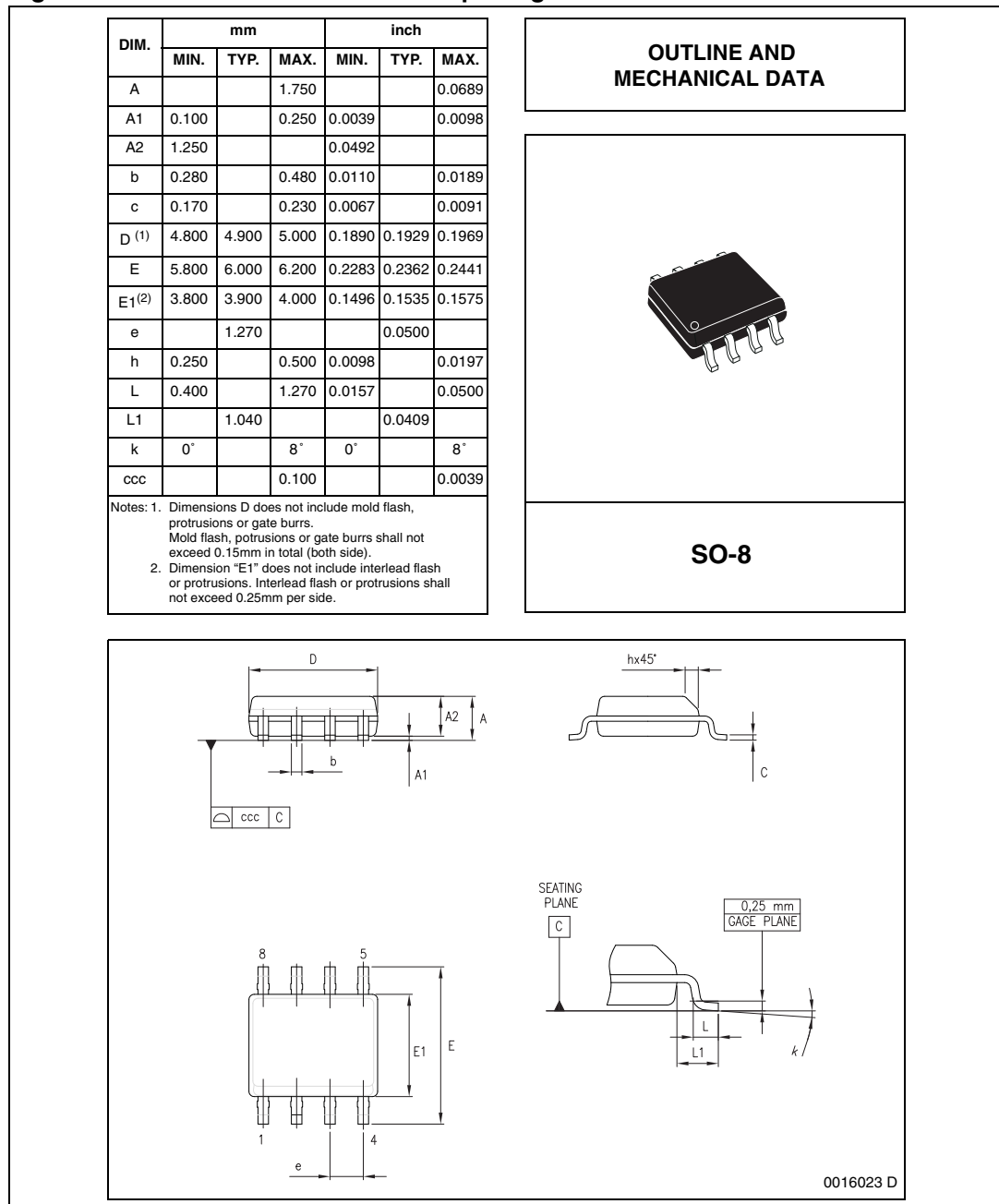

## 5 Revision history

**Table 8. Document revision history**

Date	Revision	Changes
29-Jun-2007	1	Initial release.
30-May-2008	2	Update Features section on page 1. Updated <a href="#">Table 4: Absolute maximum ratings on page 6</a> . Updated <a href="#">Table 5: Recommended operating conditions on page 7</a> .
20-Sep-2013	3	Updated disclaimer.

**Please Read Carefully:**

Information in this document is provided solely in connection with ST products. STMicroelectronics NV and its subsidiaries ("ST") reserve the right to make changes, corrections, modifications or improvements, to this document, and the products and services described herein at any time, without notice.

All ST products are sold pursuant to ST's terms and conditions of sale.

Purchasers are solely responsible for the choice, selection and use of the ST products and services described herein, and ST assumes no liability whatsoever relating to the choice, selection or use of the ST products and services described herein.

No license, express or implied, by estoppel or otherwise, to any intellectual property rights is granted under this document. If any part of this document refers to any third party products or services it shall not be deemed a license grant by ST for the use of such third party products or services, or any intellectual property contained therein or considered as a warranty covering the use in any manner whatsoever of such third party products or services or any intellectual property contained therein.

**UNLESS OTHERWISE SET FORTH IN ST'S TERMS AND CONDITIONS OF SALE ST DISCLAIMS ANY EXPRESS OR IMPLIED WARRANTY WITH RESPECT TO THE USE AND/OR SALE OF ST PRODUCTS INCLUDING WITHOUT LIMITATION IMPLIED WARRANTIES OF MERCHANTABILITY, FITNESS FOR A PARTICULAR PURPOSE (AND THEIR EQUIVALENTS UNDER THE LAWS OF ANY JURISDICTION), OR INFRINGEMENT OF ANY PATENT, COPYRIGHT OR OTHER INTELLECTUAL PROPERTY RIGHT.**

**ST PRODUCTS ARE NOT DESIGNED OR AUTHORIZED FOR USE IN: (A) SAFETY CRITICAL APPLICATIONS SUCH AS LIFE SUPPORTING, ACTIVE IMPLANTED DEVICES OR SYSTEMS WITH PRODUCT FUNCTIONAL SAFETY REQUIREMENTS; (B) AERONAUTIC APPLICATIONS; (C) AUTOMOTIVE APPLICATIONS OR ENVIRONMENTS, AND/OR (D) AEROSPACE APPLICATIONS OR ENVIRONMENTS. WHERE ST PRODUCTS ARE NOT DESIGNED FOR SUCH USE, THE PURCHASER SHALL USE PRODUCTS AT PURCHASER'S SOLE RISK, EVEN IF ST HAS BEEN INFORMED IN WRITING OF SUCH USAGE, UNLESS A PRODUCT IS EXPRESSLY DESIGNATED BY ST AS BEING INTENDED FOR "AUTOMOTIVE, AUTOMOTIVE SAFETY OR MEDICAL" INDUSTRY DOMAINS ACCORDING TO ST PRODUCT DESIGN SPECIFICATIONS. PRODUCTS FORMALLY ESCC, QML OR JAN QUALIFIED ARE DEEMED SUITABLE FOR USE IN AEROSPACE BY THE CORRESPONDING GOVERNMENTAL AGENCY.**

Resale of ST products with provisions different from the statements and/or technical features set forth in this document shall immediately void any warranty granted by ST for the ST product or service described herein and shall not create or extend in any manner whatsoever, any liability of ST.

ST and the ST logo are trademarks or registered trademarks of ST in various countries.

Information in this document supersedes and replaces all information previously supplied.

The ST logo is a registered trademark of STMicroelectronics. All other names are the property of their respective owners.

© 2013 STMicroelectronics - All rights reserved

STMicroelectronics group of companies

Australia - Belgium - Brazil - Canada - China - Czech Republic - Finland - France - Germany - Hong Kong - India - Israel - Italy - Japan - Malaysia - Malta - Morocco - Philippines - Singapore - Spain - Sweden - Switzerland - United Kingdom - United States of America

[www.st.com](http://www.st.com)