

### Features

- dual-line programmable transient voltage suppressor
- wide negative firing voltage range
- $V_{MGL} = -150\text{ V max.}$
- low dynamic switching voltages:  $V_{FP}$  and  $V_{DGL}$
- low gate triggering current:  $I_{GT} = 5\text{ mA max.}$
- peak pulse current:  $I_{PP} = 20\text{ A (10/1000 } \mu\text{s)}$
- holding current:  $I_H = 150\text{ mA min.}$

### Benefits

- A Trisil™ is not subject to ageing and provides a fail safe mode in short circuit for better protection.
- Trisils are used to help equipment meet various standards such as UL1950, IEC 950 / CSA C22.2, UL1459 and FCC part68.
- Trisils have UL94 V0 approved resin.
- Trisils are UL497B approved (file: E136224).

### Description

This device has been designed to protect 2 new high voltage, as well as classical SLICs against transient overvoltages.

Positive overvoltages are clamped by 2 diodes. Negative surges are suppressed by 2 thyristors, their breakdown voltage being referenced to  $-V_{BAT}$  through the gate.

This component presents a very low gate triggering current ( $I_{GT}$ ) to reduce the current consumption on printed circuit boards during the firing phase.

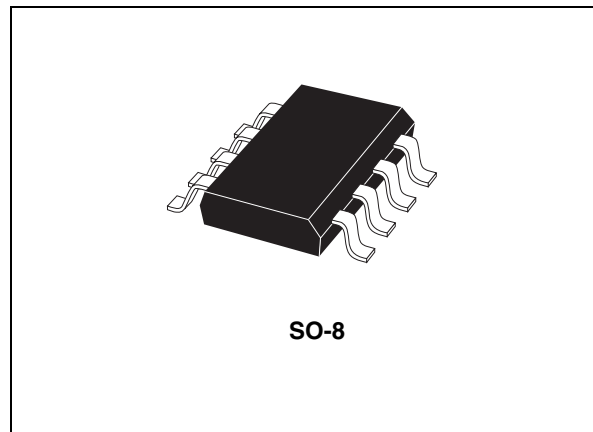
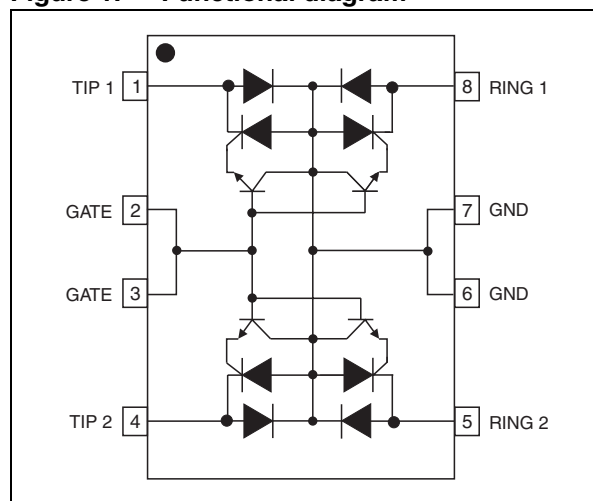

Figure 1. Functional diagram



TM: Trisil is a trademark of STMicroelectronics

# 1 Compliant with the following standards

Table 1. Compliant with the following standards

Standard	Peak surge voltage (V)	Voltage waveform	Required peak current (A)	Current waveform	Minimum serial resistor to meet standard ( $\Omega$ )
<b>GR-1089 Core First level</b>	2500	2/10 $\mu$ s	500	2/10 $\mu$ s	31
	1000	10/1000 $\mu$ s	100	10/1000 $\mu$ s	40
<b>GR-1089 Core Second level</b>	5000	2/10 $\mu$ s	500	2/10 $\mu$ s	62
<b>GR-1089 Core Intra-building</b>	1500	2/10 $\mu$ s	100	2/10 $\mu$ s	7
<b>ITU-T-K20/K21</b>	6000	10/700 $\mu$ s	150	5/310 $\mu$ s	200
	1500		37.5		20
<b>ITU-T-K20 (IEC 61000-4-2)</b>	8000	1/60 ns	ESD contact discharge		0
	15000		ESD air discharge		0
<b>VDE0433</b>	4000	10/700 $\mu$ s	100	5/310 $\mu$ s	120
	2000		50		40
<b>VDE0878</b>	4000	1.2/50 $\mu$ s	100	1/20 $\mu$ s	27
	2000		50		0
<b>IEC 61000-4-5</b>	4000	10/700 $\mu$ s	100	5/310 $\mu$ s	120
	4000	1.2/50 $\mu$ s	100	8/20 $\mu$ s	27
<b>FCC Part 68, lightning surge type A</b>	1500	10/160 $\mu$ s	200	10/160 $\mu$ s	43
	800	10/560 $\mu$ s	100	10/560 $\mu$ s	32
<b>FCC Part 68, lightning surge type B</b>	1000	9/720 $\mu$ s	25	5/320 $\mu$ s	0

## 2 Characteristics

**Table 2. Thermal resistance**

Symbol	Parameter	Value	Unit
$R_{th(j-a)}$	Junction to ambient	170	°C/W

**Figure 2. Electrical characteristics ( $T_{amb} = 25\text{ °C}$ )**

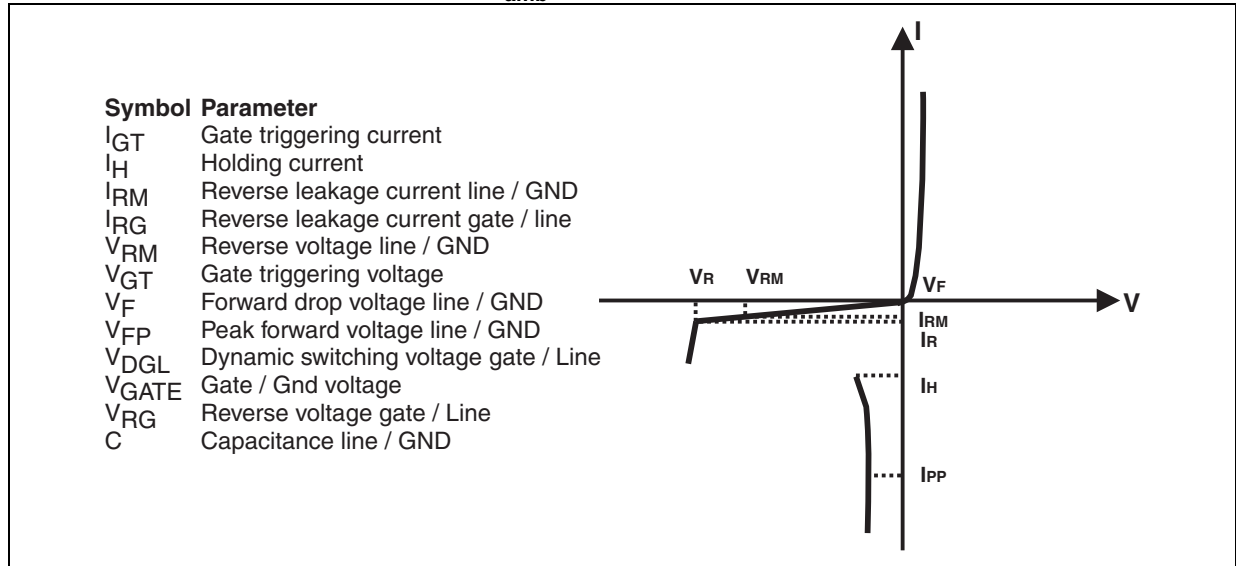
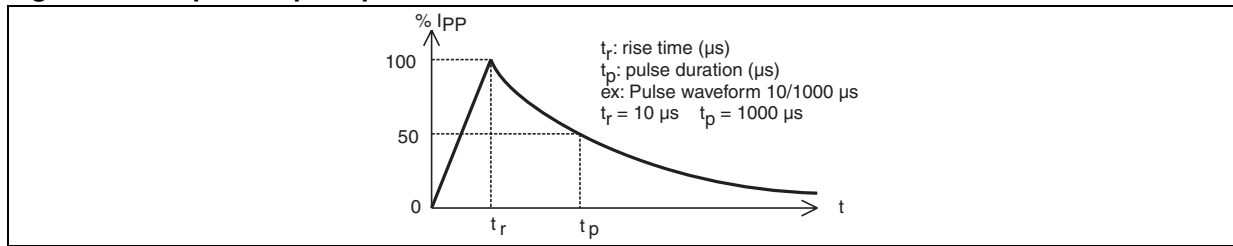

**Table 3. Absolute ratings ( $T_{amb} = 25\text{ °C}$ , unless otherwise specified)**

Symbol	Parameter	Value	Unit	
$I_{PP}$	Peak pulse current <sup>(1)</sup>	10/1000 $\mu$ s	20	A
		8/20 $\mu$ s	60	
		10/560 $\mu$ s	20	
		5/310 $\mu$ s	25	
		10/160 $\mu$ s	30	
		1/20 $\mu$ s	60	
		2/10 $\mu$ s	70	
$I_{TSM}$	Non repetitive surge peak on-state current (50 Hz sinusoidal)	t = 10 ms	5	A
		t = 1 s	3.5	
$I^2t$	$I^2t$ value for fusing (50 Hz sinusoidal)	t = 10 ms	0.125	$A^2s$
$I_{GSM}$	Maximum gate current (50 Hz sinusoidal)	t = 10 ms	2	A
$V_{MLG}$ $V_{MGL}$	Maximum voltage LINE/GND	-40 °C < $T_{amb}$ < +85 °C	-150	V
	Maximum voltage GATE/LINE	-40 °C < $T_{amb}$ < +85 °C	-150	
$T_{stg}$ $T_j$	Storage temperature range		- 55 to + 150	°C
	Maximum junction temperature		150	
$T_L$	Maximum lead temperature for soldering during 10 s		260	°C

1. For pulse waveform see [Figure 3](#).

**Figure 3. Repetitive peak pulse current**



**Table 4. Parameters related to the diode line / GND ( $T_{amb} = 25\text{ }^{\circ}\text{C}$ )**

Symbol	Test conditions				Max	Unit
$V_F$	$I_F = 1\text{ A}$		$t = 500\text{ }\mu\text{s}$		2	V
$V_{FP}^{(1)}$	10/700 $\mu\text{s}$	1.5 kV	$R_S = 110\text{ }\Omega$	$I_{PP} = 10\text{ A}$	5	V
	1.2/50 $\mu\text{s}$	1.5 kV	$R_S = 60\text{ }\Omega$	$I_{PP} = 15\text{ A}$	10	
	2/10 $\mu\text{s}$	2.5 kV	$R_S = 245\text{ }\Omega$	$I_{PP} = 10\text{ A}$	20	

1. See [Figure 5: Test circuit for  \$V\_{FP}\$  and  \$V\_{DGL}\$  parameters](#).  $R_S$  is the protection resistor located on the line card.

**Table 5. Parameters related to the protection thyristor ( $T_{amb} = 25\text{ }^{\circ}\text{C}$  unless otherwise specified)**

Symbol	Test conditions				Min	Max	Unit
$I_{GT}$	$V_{GND} / \text{LINE} = -48\text{ V}$				0.1	5	mA
$I_H$	$V_{GATE} = -48\text{ V}^{(1)}$				150		mA
$V_{GT}$	At $I_{GT}$					2.5	V
$I_{RG}$	$V_{RG} = -150\text{ V}$		$T_c = 25\text{ }^{\circ}\text{C}$			5	$\mu\text{A}$
	$V_{RG} = -150\text{ V}$		$T_c = 85\text{ }^{\circ}\text{C}$			50	
$V_{DGL}$	$V_{GATE} = -48\text{ V}^{(2)}$						
	10/700 $\mu\text{s}$	1.5 kV	$R_S = 110\text{ }\Omega$	$I_{PP} = 10\text{ A}$		5	V
	1.2/50 $\mu\text{s}$	1.5 kV	$R_S = 60\text{ }\Omega$	$I_{PP} = 15\text{ A}$		10	
2/10 $\mu\text{s}$	2.5 kV	$R_S = 245\text{ }\Omega$	$I_{PP} = 10\text{ A}$		20		

1. See [Figure 4: Functional holding current \( \$I\_H\$ \) test circuit: go no-go test](#)

2. See [Figure 5: Test circuit for  \$V\_{FP}\$  and  \$V\_{DGL}\$  parameters](#). The oscillations with a time duration lower than 50 ns are not taken into account

**Table 6. Parameters related to diode and protection thyristor ( $T_{amb} = 25\text{ }^{\circ}\text{C}$ , unless otherwise specified)**

Symbol	Test conditions			Typ.	Max.	Unit
$I_{RM}$	$V_{GATE} / \text{LINE} = -1\text{ V}$ $V_{RM} = -150\text{ V}$		$T_c = 25\text{ }^{\circ}\text{C}$		5	$\mu\text{A}$
	$V_{GATE} / \text{LINE} = -1\text{ V}$ $V_{RM} = -150\text{ V}$		$T_c = 85\text{ }^{\circ}\text{C}$		50	
C	$V_R = 50\text{ V}$ bias, $V_{RMS} = 1\text{ V}$ , $F = 1\text{ MHz}$			20		pF
	$V_R = 2\text{ V}$ bias, $V_{RMS} = 1\text{ V}$ , $F = 1\text{ MHz}$			48		

### 3 Test circuits

#### 3.1 Functional holding current ( $I_H$ ): go no-go test

Figure 4. Functional holding current ( $I_H$ ) test circuit: go no-go test

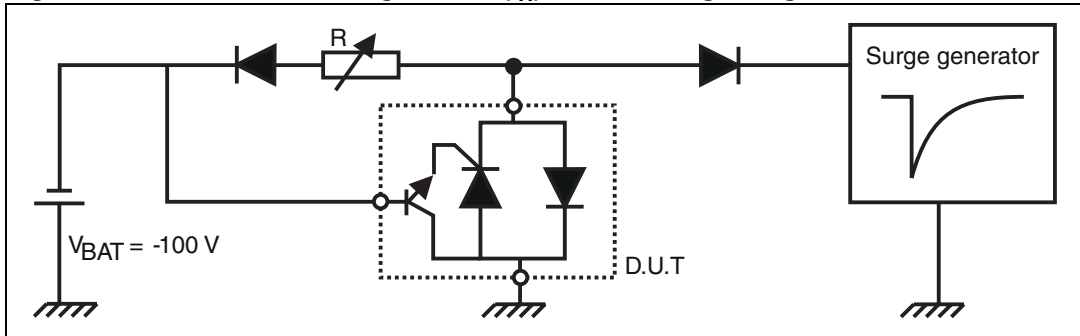

This is a go no-go test, which confirms the holding current ( $I_H$ ) level in a functional test circuit.

##### 3.1.1 Test procedure

- Adjust the current level at the  $I_H$  value by short circuiting the D.U.T.
- Fire the D.U.T. with a surge current:  $I_{PP} = 10\text{ A}$ ,  $10/1000\ \mu\text{s}$ .

The D.U.T. will come back to the off-state within a duration of 50 ms max.

#### 3.2 Test circuit for $V_{FP}$ and $V_{DGL}$ parameters

Figure 5. Test circuit for  $V_{FP}$  and  $V_{DGL}$  parameters

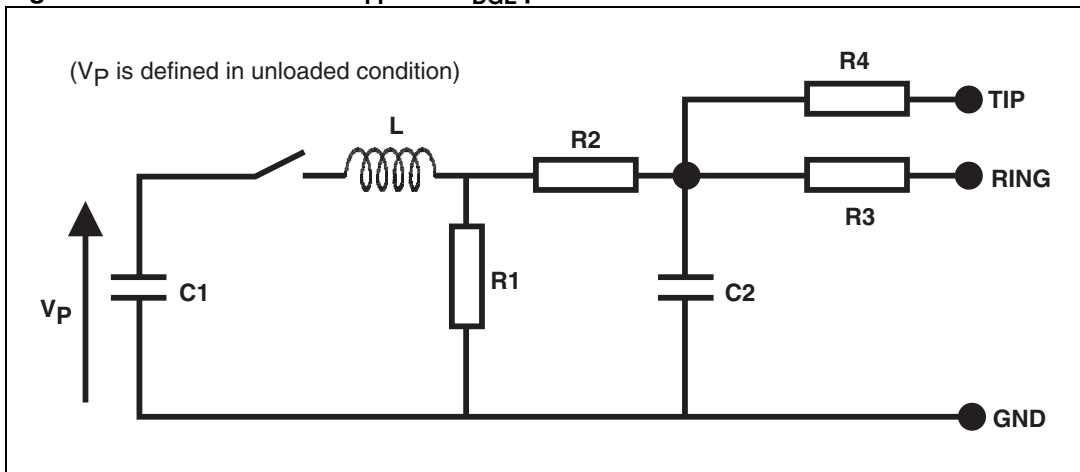

Table 7. Test circuit component values

Pulse ( $\mu\text{s}$ )		$V_p$ (V)	$C_1$ ( $\mu\text{F}$ )	$C_2$ (nF)	L ( $\mu\text{H}$ )	$R_1$ ( $\Omega$ )	$R_2$ ( $\Omega$ )	$R_3$ ( $\Omega$ )	$R_4$ ( $\Omega$ )	$I_{pp}$ (A)	$R_s$ ( $\Omega$ )
$t_r$	$t_p$										
10	700	1500	20	200	0	50	15	25	25	10	110
1.2	50	1500	1	33	0	76	13	25	25	15	60
2	10	2500	10	0	1.1	1.3	0	3	3	10	245

## 4 Technical information

Figure 6. LCDP1521 concept behavior

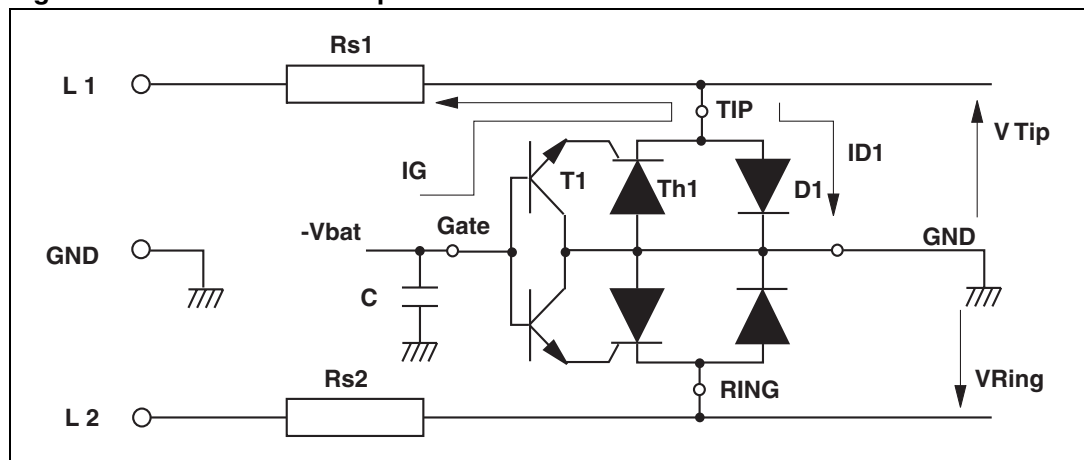

Figure 6 shows the classic protection circuit using the LCDP1521 crowbar concept. This topology has been developed to protect the new high voltage SLICs. This supports the programming of the negative firing threshold while the positive clamping value is fixed at GND.

When a negative surge occurs on one wire (L1 for example), a current  $I_G$  flows through the base of the transistor T1 and then injects a current in the gate of the thyristor Th1. Th1 fires and all the surge current flows through the ground. After the surge when the current flowing through Th1 becomes less negative than the holding current  $I_H$ , then Th1 switches off.

When a positive surge occurs on one wire (L1 for example), the diode D1 conducts and the surge current flows through the ground.

The capacitor C is used to speed up the crowbar structure firing during the fast surge edges.

This minimizes the dynamic breakover voltage at the SLIC Tip and Ring inputs during fast strikes. Note that this capacitor is generally present around the SLIC -  $V_{BAT}$  pin.

So, to be efficient, it has to be as close as possible to the LCDP1521 Gate pin and to the reference ground track (or plan). The optimized value for C is 220 nF.

The series resistors Rs1 and Rs2 in Figure 6 represent the fuse resistors or the PTC which are mandatory to withstand the power contact or the power induction tests imposed by the

various country standards. Taking into account this fact, the actual lightning surge current flowing through the LCDP is equal to:

$$I_{\text{surge}} = V_{\text{surge}} / (R_g + R_s)$$

With:

$V_{\text{surge}}$  = peak surge voltage imposed by the standard.

$R_g$  = series resistor of the surge generator

$R_s$  = series resistor of the line card (equivalent to PTC + R in [Figure 7](#))

**Example:** For a line card with 60 Ω of series resistors, which has to be qualified under GR-1089 Core 1000 V, 10/1000µs surge, the actual current through the LCDP1521 is equal to:

$$I_{\text{surge}} = 1000 / (10 + 60) = 14 \text{ A}$$

The LCDP1521 is particularly optimized for the new telecom applications such as the fiber in the loop, the WLL, and the remote central office. In this case the operating voltages are smaller than in the classic system. This makes the high voltage SLICs particularly suitable. The schematics of [Figure 7](#) show the topologies most frequently used for these applications.

**Figure 7. Protection of high voltage SLICs**

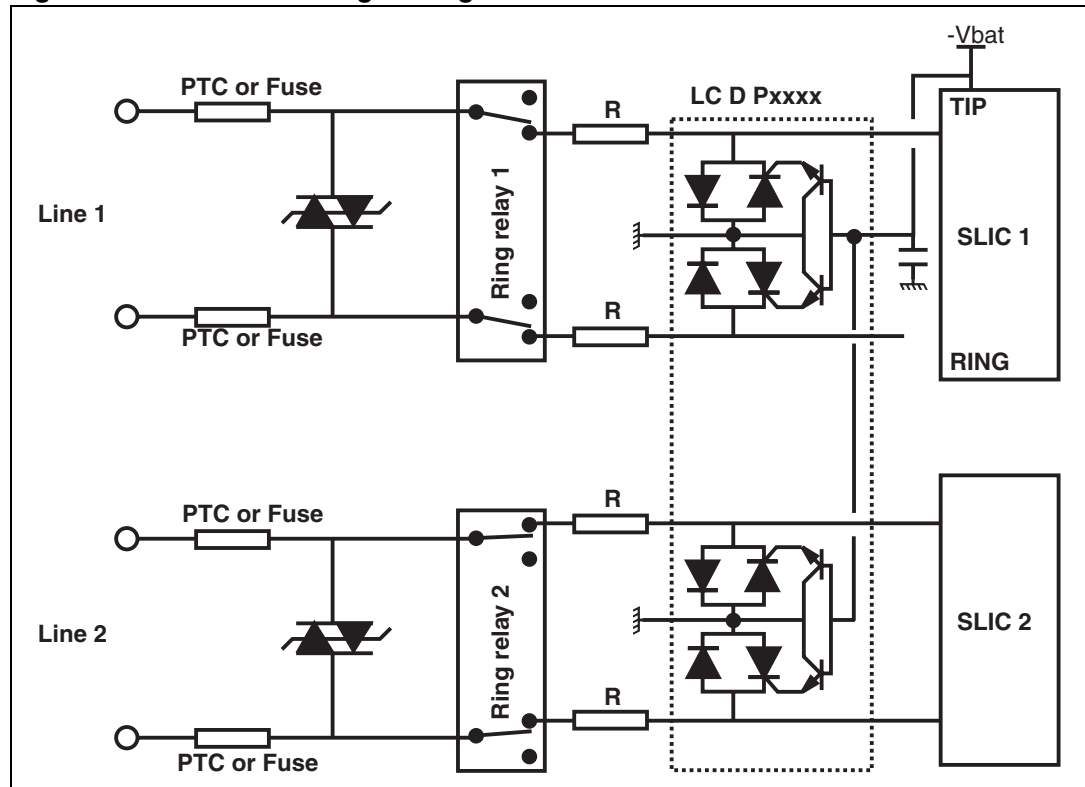

Figure 8. Surge peak current versus overload duration.

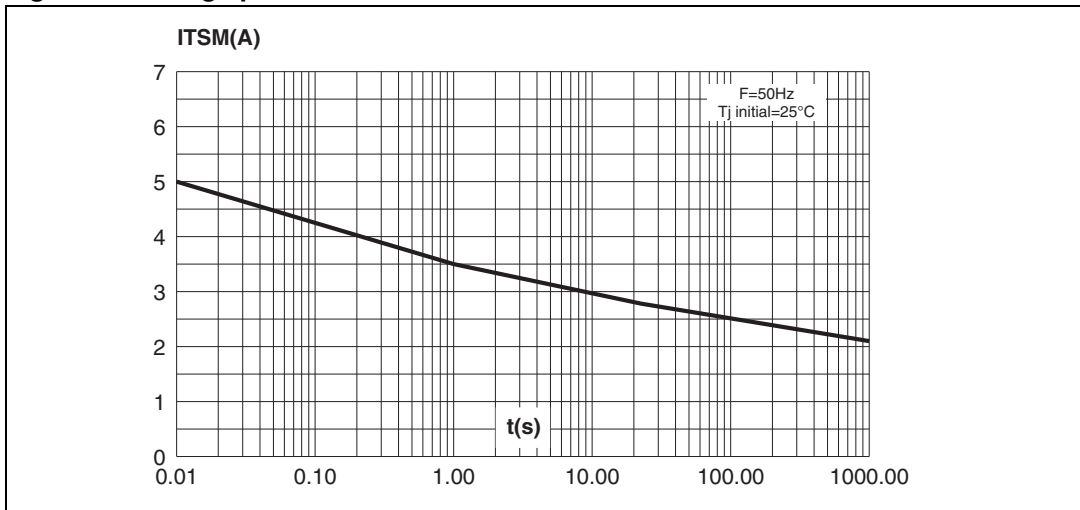
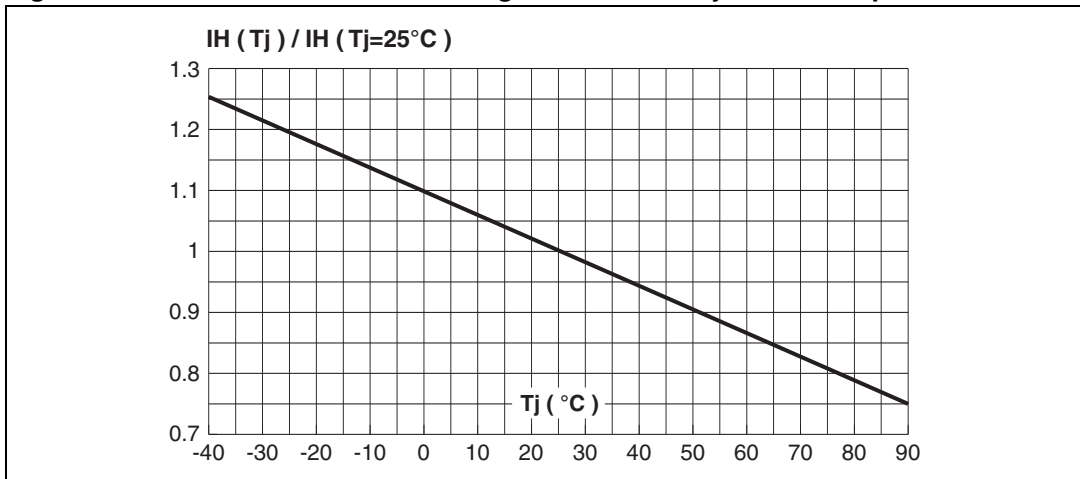

Figure 9. Relative variation of holding current versus junction temperature





## 5 Ordering information scheme

Figure 10. Ordering information scheme

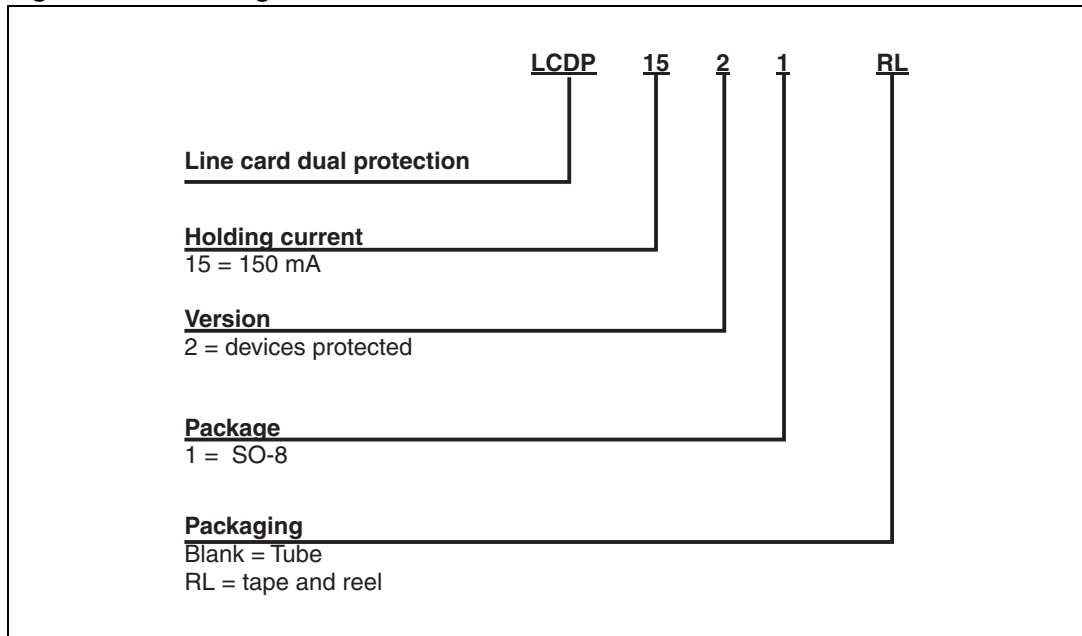

## 6 Package information

- Epoxy meets UL94, V0
- Lead-free package

In order to meet environmental requirements, ST offers these devices in different grades of ECOPACK® packages, depending on their level of environmental compliance. ECOPACK® specifications, grade definitions and product status are available at: [www.st.com](http://www.st.com). ECOPACK® is an ST trademark.

**Table 8. SO-8 dimensions**

Ref.	Dimensions					
	Millimeters			Inches		
	Min.	Typ.	Max.	Min.	Typ.	Max.
A			1.75			0.069
A1	0.1		0.25	0.004		0.010
A2	1.25			0.049		
b	0.28		0.48	0.011		0.019
C	0.17		0.23	0.007		0.009
D	4.80	4.90	5.00	0.189	0.193	0.197
E	5.80	6.00	6.20	0.228	0.236	0.244
E1	3.80	3.90	4.00	0.150	0.154	0.157
e		1.27			0.050	
h	0.25		0.50	0.010		0.020
L	0.40		1.27	0.016		0.050
L1		1.04			0.041	
k	0°		8°	0°		8°
ppp			0.10			0.004

**Figure 11. Footprint, dimensions in mm (inches)**

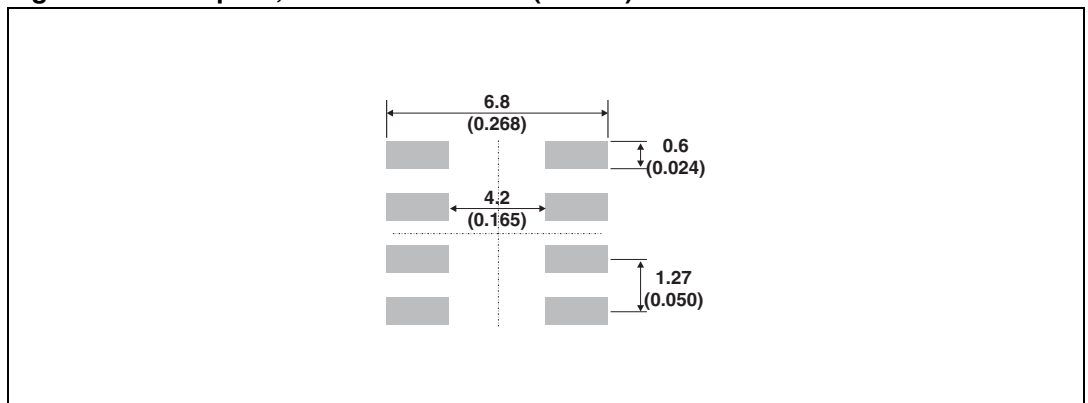

## 7 Ordering Information

**Table 9. Ordering information**

Order code	Marking	Package	Weight	Base qty	Delivery mode
LCDP1521	CDP152	SO-8	0.08 g	100	Tube
LCDP1521RL <sup>(1)</sup>				2500	Tape and reel

1. Preferred device

## 8 Revision history

**Table 10. Document revision history**

Date	Revision	Changes
March 2002	1	Initial release.
24-Jun-2005	2	Peak pulse current changed from 15 to 20 A (10/1000 $\mu$ s)
07-Feb-2006	3	Added footnote to ordering information table
20-Oct-2010	4	Updated ECOPACK statement. Updated trademark statement.

**Please Read Carefully:**

Information in this document is provided solely in connection with ST products. STMicroelectronics NV and its subsidiaries ("ST") reserve the right to make changes, corrections, modifications or improvements, to this document, and the products and services described herein at any time, without notice.

All ST products are sold pursuant to ST's terms and conditions of sale.

Purchasers are solely responsible for the choice, selection and use of the ST products and services described herein, and ST assumes no liability whatsoever relating to the choice, selection or use of the ST products and services described herein.

No license, express or implied, by estoppel or otherwise, to any intellectual property rights is granted under this document. If any part of this document refers to any third party products or services it shall not be deemed a license grant by ST for the use of such third party products or services, or any intellectual property contained therein or considered as a warranty covering the use in any manner whatsoever of such third party products or services or any intellectual property contained therein.

**UNLESS OTHERWISE SET FORTH IN ST'S TERMS AND CONDITIONS OF SALE ST DISCLAIMS ANY EXPRESS OR IMPLIED WARRANTY WITH RESPECT TO THE USE AND/OR SALE OF ST PRODUCTS INCLUDING WITHOUT LIMITATION IMPLIED WARRANTIES OF MERCHANTABILITY, FITNESS FOR A PARTICULAR PURPOSE (AND THEIR EQUIVALENTS UNDER THE LAWS OF ANY JURISDICTION), OR INFRINGEMENT OF ANY PATENT, COPYRIGHT OR OTHER INTELLECTUAL PROPERTY RIGHT.**

**UNLESS EXPRESSLY APPROVED IN WRITING BY AN AUTHORIZED ST REPRESENTATIVE, ST PRODUCTS ARE NOT RECOMMENDED, AUTHORIZED OR WARRANTED FOR USE IN MILITARY, AIR CRAFT, SPACE, LIFE SAVING, OR LIFE SUSTAINING APPLICATIONS, NOR IN PRODUCTS OR SYSTEMS WHERE FAILURE OR MALFUNCTION MAY RESULT IN PERSONAL INJURY, DEATH, OR SEVERE PROPERTY OR ENVIRONMENTAL DAMAGE. ST PRODUCTS WHICH ARE NOT SPECIFIED AS "AUTOMOTIVE GRADE" MAY ONLY BE USED IN AUTOMOTIVE APPLICATIONS AT USER'S OWN RISK.**

Resale of ST products with provisions different from the statements and/or technical features set forth in this document shall immediately void any warranty granted by ST for the ST product or service described herein and shall not create or extend in any manner whatsoever, any liability of ST.

ST and the ST logo are trademarks or registered trademarks of ST in various countries.

Information in this document supersedes and replaces all information previously supplied.

The ST logo is a registered trademark of STMicroelectronics. All other names are the property of their respective owners.

© 2010 STMicroelectronics - All rights reserved

STMicroelectronics group of companies

Australia - Belgium - Brazil - Canada - China - Czech Republic - Finland - France - Germany - Hong Kong - India - Israel - Italy - Japan - Malaysia - Malta - Morocco - Philippines - Singapore - Spain - Sweden - Switzerland - United Kingdom - United States of America

[www.st.com](http://www.st.com)