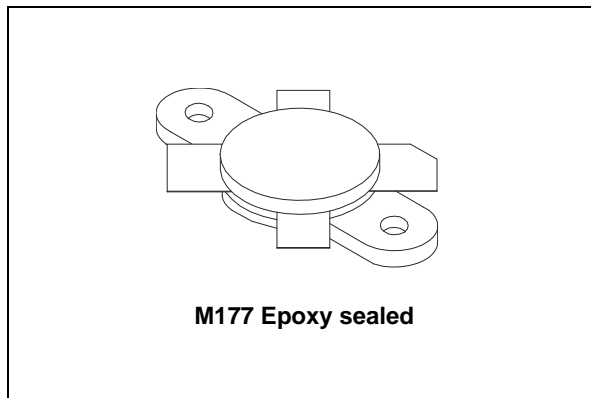
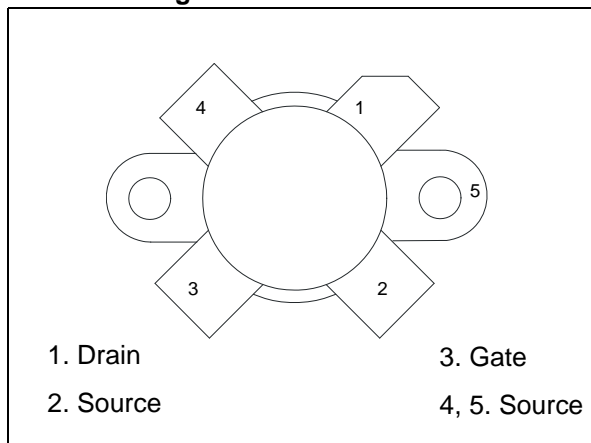

HF/VHF/UHF RF power N-channel MOSFETs

Datasheet - production data

**Figure 1. Pin connection****Features**

- Gold metalization
- Excellent thermal stability
- Common source configuration
- $P_{OUT} = 300$ W min. with 20 dB gain @ 30 MHz
- Thermally enhanced packaging for lower junction temperatures

Description

The SD2933 is a gold metalized N-channel MOS field-effect RF power transistor, intended for use in 50 V dc large signal applications up to 150 MHz. Its special low thermal resistance package makes it ideal for ISM applications, where reliability and ruggedness are critical factors.

Table 1. Device summary

Order code	Marking	Package	Packaging
SD2933W	SD2933 ⁽¹⁾	M177	Plastic tray

1. For more details please refer to [Chapter 6: Marking, packing and shipping specifications](#).

Contents

- 1 Electrical data 3**
 - 1.1 Maximum rating 3
 - 1.2 Thermal data 3
- 2 Electrical characteristics 4**
- 3 Impedance 5**
- 4 Typical performance (30 MHz) 6**
 - 4.1 Test circuit (30 MHz) 9
- 5 Package information 12**
- 6 Marking, packing and shipping specifications 14**
- 7 Revision history 15**

1 Electrical data

1.1 Maximum rating

$$T_{\text{CASE}} = 25 \text{ }^{\circ}\text{C}$$

Table 2. Absolute maximum ratings

Symbol	Parameter	Value	Unit
$V_{(\text{BR})\text{DSS}}$	Drain source voltage	125	V
V_{DGR}	Drain-gate voltage ($R_{\text{GS}} = 1\text{M}\Omega$)	125	V
V_{GS}	Gate-source voltage	± 40	V
I_{D}	Drain current	40	A
P_{DISS}	Power dissipation	648	W
E_{AS}	Avalanche energy, single pulse ($I_{\text{D}} = 53 \text{ A}$, $800 \text{ }\mu\text{H}$ coil)	1100	mJ
$E_{\text{AR}}^{(1)}$	Avalanche energy, repetitive	50	mJ
T_{J}	Max. operating junction temperature	200	$^{\circ}\text{C}$
T_{STG}	Storage temperature	-65 to +150	$^{\circ}\text{C}$

1. Repetitive rating: Pulse width limited by maximum junction temperature / repetitive avalanche causes additional power losses that can be calculated as: $P_{\text{AV}} = E_{\text{AR}} * f$

1.2 Thermal data

Table 3. Thermal data

Symbol	Parameter	Value	Unit
$R_{\text{thJ-C}}$	Junction to case thermal resistance	0.27	$^{\circ}\text{C/W}$

2 Electrical characteristics

T_{CASE} = 25 °C

Table 4. Static

Symbol	Test conditions			Min.	Typ.	Max.	Unit
V _{(BR)DSS}	V _{GS} = 0 V	I _{DS} = 200 mA		125			V
I _{DSS}	V _{GS} = 0 V	V _{DS} = 50 V				100	μA
I _{GSS}	V _{GS} = 20 V	V _{DS} = 0 V				500	nA
V _{GS(Q)} ⁽¹⁾	V _{DS} = 10 V	I _D = 250 mA		1.5		4	V
V _{DS(ON)}	V _{GS} = 10 V	I _D = 20 A				3.0	V
G _{FS} ⁽¹⁾	V _{DS} = 10 V	I _D = 10 A		see Table 5: G_{FS} sort			mho
C _{ISS}	V _{GS} = 0 V	V _{DS} = 50 V	f = 1 MHz		1000		pF
C _{OSS}	V _{GS} = 0 V	V _{DS} = 50 V	f = 1 MHz		372		pF
C _{RSS}	V _{GS} = 0 V	V _{DS} = 50 V	f = 1 MHz		29		pF

1. V_{GS(Q)} and G_{FS} sorted with alpha/numeric code marked on unit.

Table 5. G_{FS} sort

G _{FS} sort	Value
A	10 - 10.99
B	11 - 11.99
C	12 - 12.99
D	13 - 13.99
E	14 - 14.99
F	15 - 15.99
G	16 - 16.99
H	17 - 18

Table 6. Dynamic

Symbol	Test Conditions	Min.	Typ.	Max.	Unit
P _{OUT}	V _{DD} = 50 V I _{DQ} = 250 mA f = 30 MHz	300	400		W
G _{PS}	V _{DD} = 50 V I _{DQ} = 250 mA P _{OUT} = 300 W f = 30 MHz	20	23.5		dB
η _D	V _{DD} = 50 V I _{DQ} = 250 mA P _{OUT} = 150 W f = 30 MHz	50	65		%
Load mismatch	V _{DD} = 50 V I _{DQ} = 250 mA P _{OUT} = 300 W f = 30 MHz all phase angles	3:1			VSWR

3 Impedance

Figure 2. Impedance data schematic

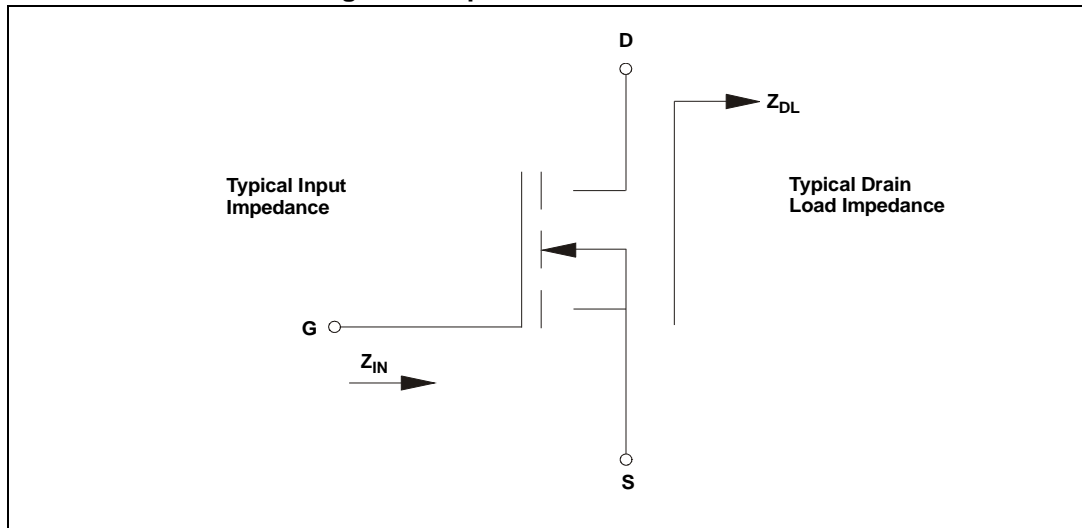

Table 7. Impedance data

f	Z_{IN} (Ω)	Z_{DL} (Ω)
30 MHz	$1.8 - j 0.2$	$2.8 + j 2.3$
108 MHz	$1.9 + j 0.2$	$1.6 + j 1.4$
175 MHz	$1.9 + j 0.3$	$1.5 + j 1.6$

4 Typical performance (30 MHz)

Figure 3. Capacitance vs. drain voltage

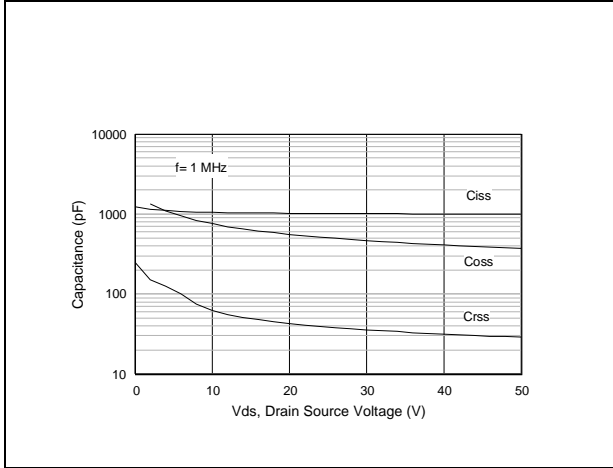

Figure 4. Drain current vs. gate voltage

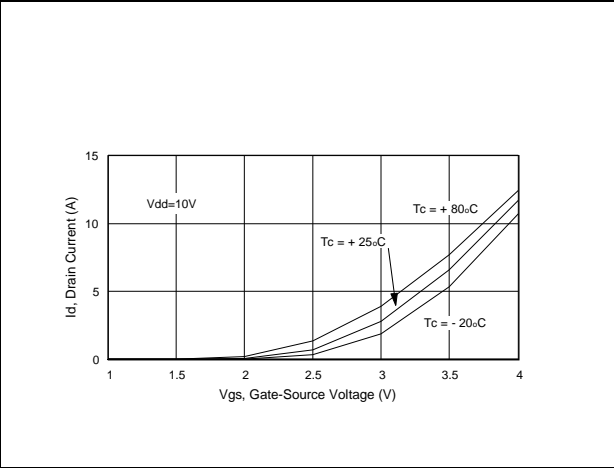

Figure 5. Gate-source voltage vs. case temperature

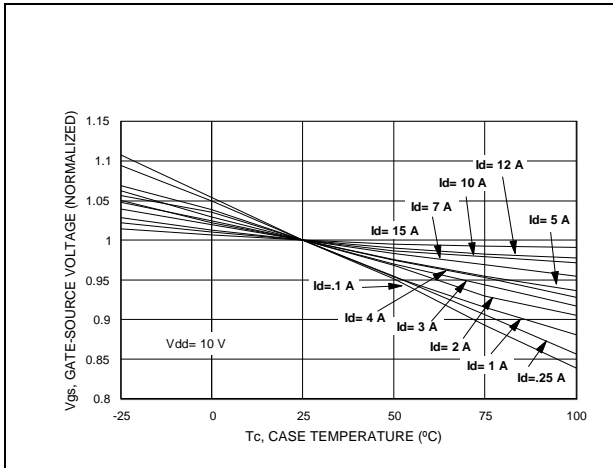

Figure 6. Maximum thermal resistance vs. case temperature

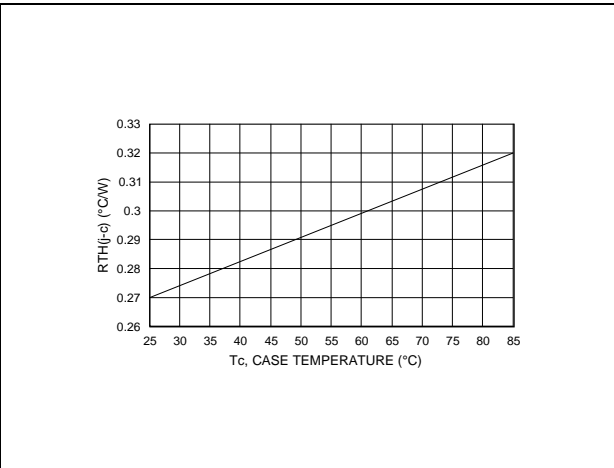

Figure 7. Transient thermal impedance

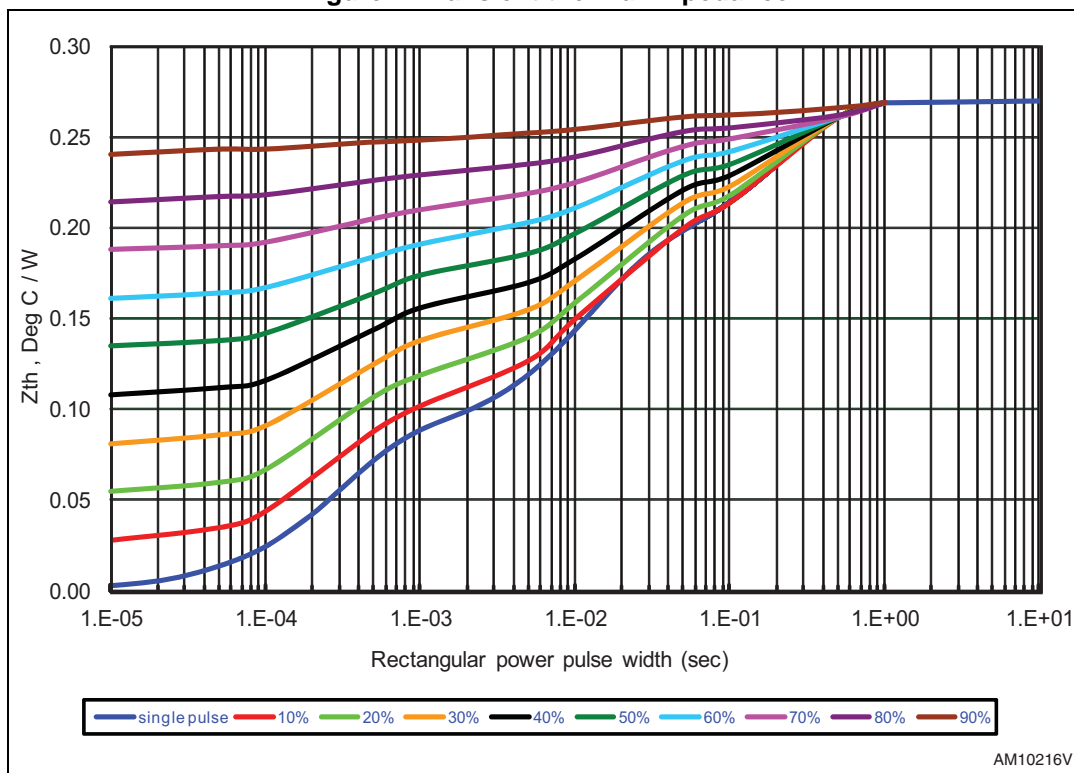

Figure 8. Transient thermal impedance model

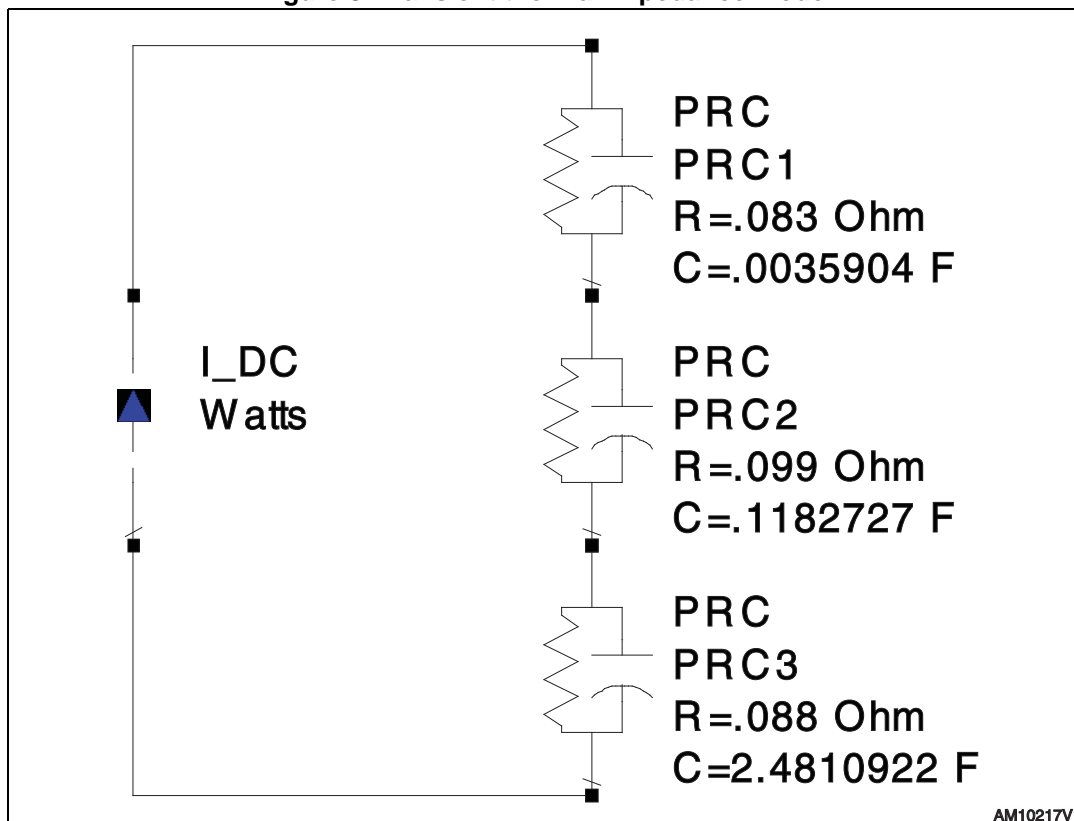

Figure 9. Output power vs. input power

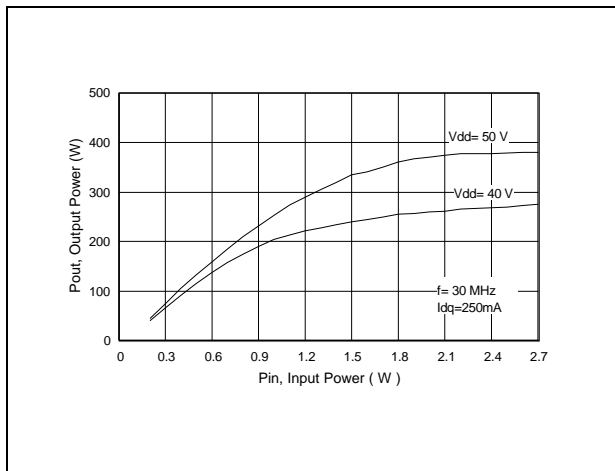

Figure 10. Output power vs. input power (at different temperature)

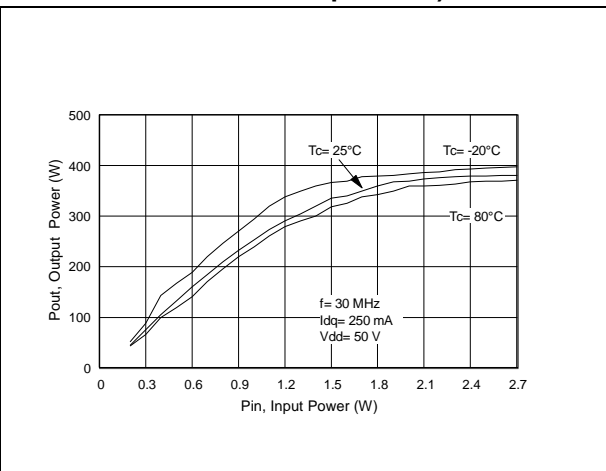

Figure 11. Power gain vs. output power

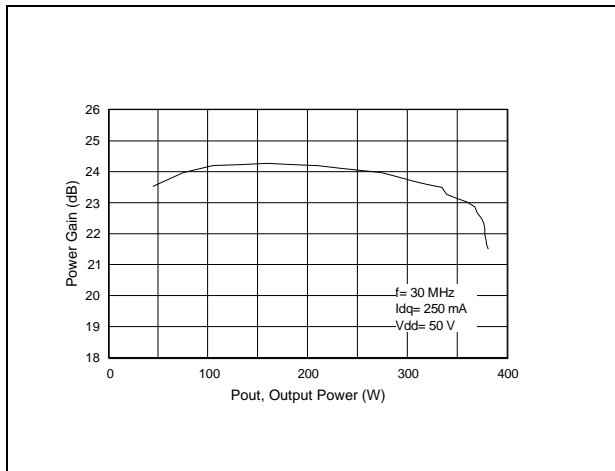

Figure 12. Efficiency vs. output power

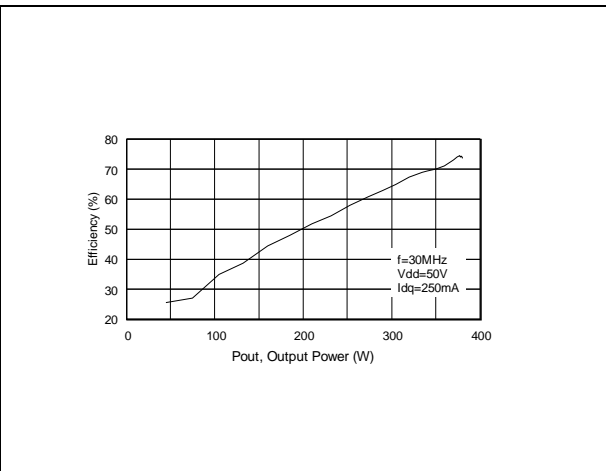

Figure 13. Output power vs. supply voltage

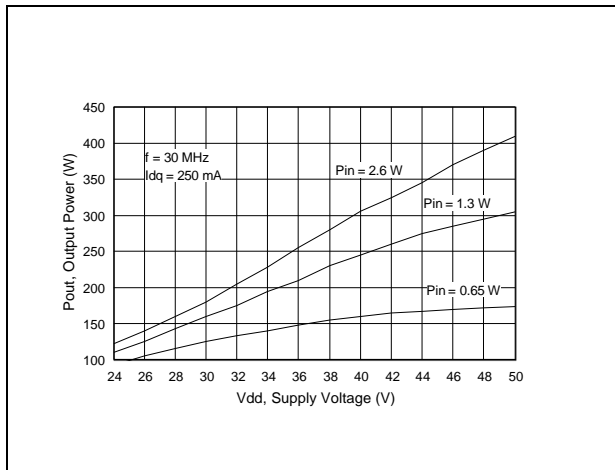
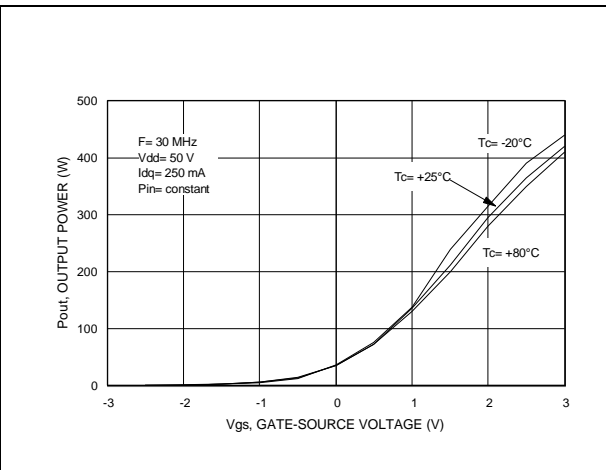

Figure 14. Output power vs. gate voltage



4.1 Test circuit (30 MHz)

Figure 15. 30 MHz test circuit schematic

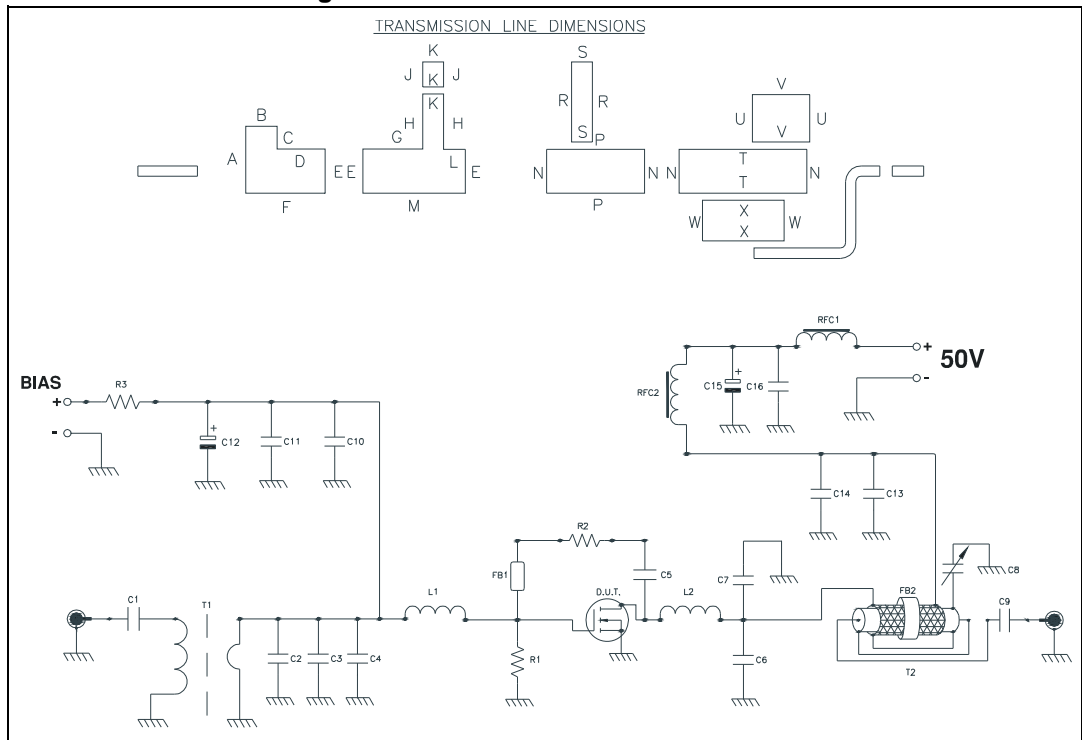

Table 8. Transmission line dimensions

Dim.	Inch	mm
A	0.532	13.51
B	0.250	6.35
C	0.181	4.59
D	0.383	9.37
E	0.351	8.91
F	0.633	16.08
G	0.477	12.12
H	0.438	11.12
J	0.200	5.08
K	0.164	4.16
L	0.174	4.42
M	0.817	20.75
N	0.350	8.89
P	0.779	19.79
R	0.639	16.23

Table 8. Transmission line dimensions (continued)

Dim.	Inch	mm
S	0.165	4.19
T	1.017	25.84
U	0.375	9.52
V	0.456	11.58
W	0.325	8.24
X	0.650	16.50

Table 9. 30 MHz test circuit part list

Component	Description
C1,C9	0.01 μ F / 500 V surface mount ceramic chip capacitor
C2, C3	750 pF ATC 700B surface mount ceramic chip capacitor
C4	300 pF ATC 700B surface mount ceramic chip capacitor
C5,C10,C11,C14,C16	10000 pF ATC 200B surface mount ceramic chip capacitor
C6	510 pF ATC 700B surface mount ceramic chip capacitor
C7	300 pF ATC 700B surface mount ceramic chip capacitor
C8	175-680 pF type 46 standard trimmer capacitor
C12	47 μ F / 63 V aluminum electrolytic radial lead capacitor
C13	1200 pF ATC 700B surface mount ceramic chip capacitor
C15	100 μ F / 63 V aluminum electrolytic radial lead capacitor
R1,R3	1 K OHM 1 W surface mount chip resistor
R2	560 OHM 2 W wire-wound axis lead resistor
T1	HF 2-30 MHz surface mount 9:1 transformer
T2	RG - 142B/U 50 OHM coaxial cable OD = 0.165[4.18] L 15"[381.00] covered with 15"[381.00] tinned copper tubular brand 13/65" [5.1] width
L1	1 3/4 turn air-wound 16 AWG ID = 0.219 [5.56] poly-coated magnet wire
L2	1 3/4 turn air-wound 12 AWG ID = 0.250 [6.34] bus bar wire
RFC1,RFC2	3 turns 14 AWG wire through ferrite toroid
FB1	Surface mount EMI shield bead
FB2	Toroid
PCB	ULTRALAM 2000. 0.030" THK, $\epsilon_r = 2.55$, 2 Oz ED CU both sides

Figure 16. 30 MHz test circuit photomaster

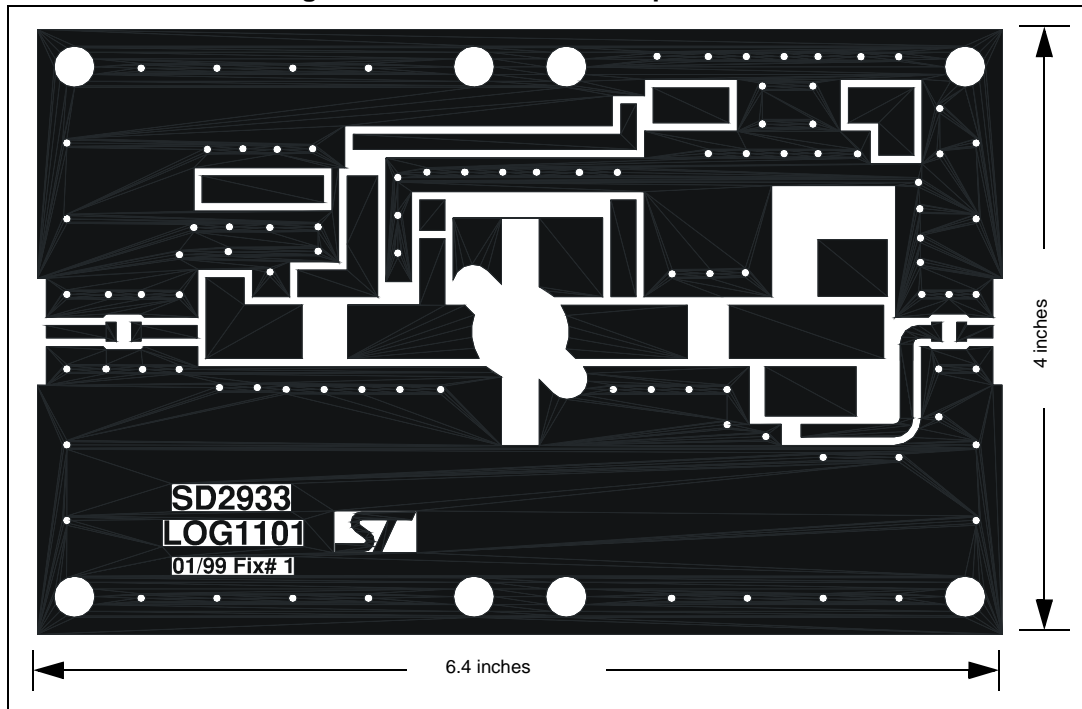
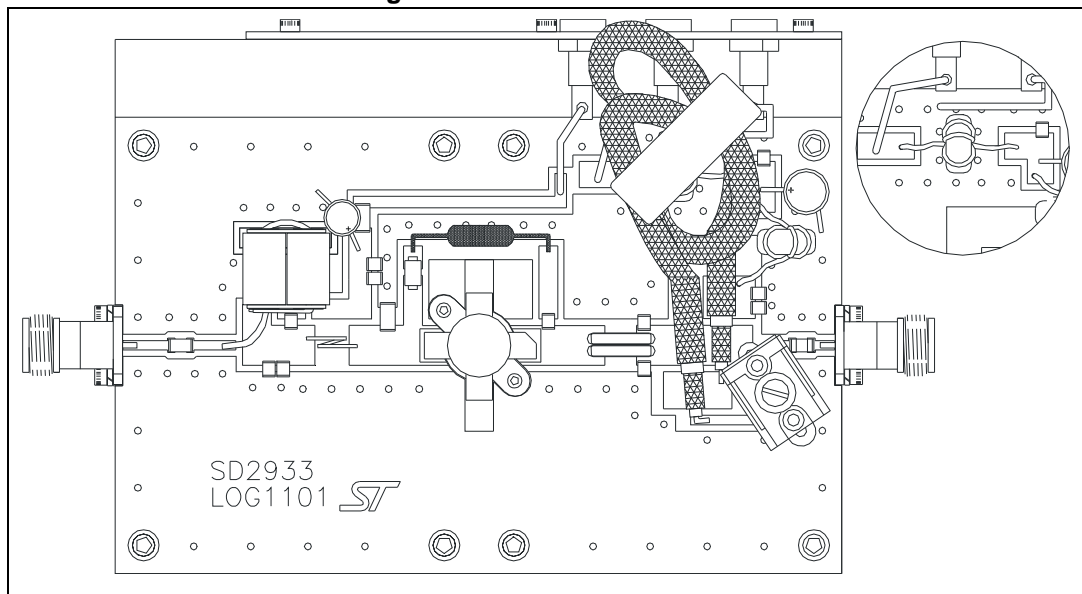

Figure 17. 30 MHz test circuit



5 Package information

In order to meet environmental requirements, ST offers these devices in different grades of ECOPACK® packages, depending on their level of environmental compliance. ECOPACK® specifications, grade definitions and product status are available at: www.st.com. ECOPACK is an ST trademark.

Figure 18. M177 package outline^(a)

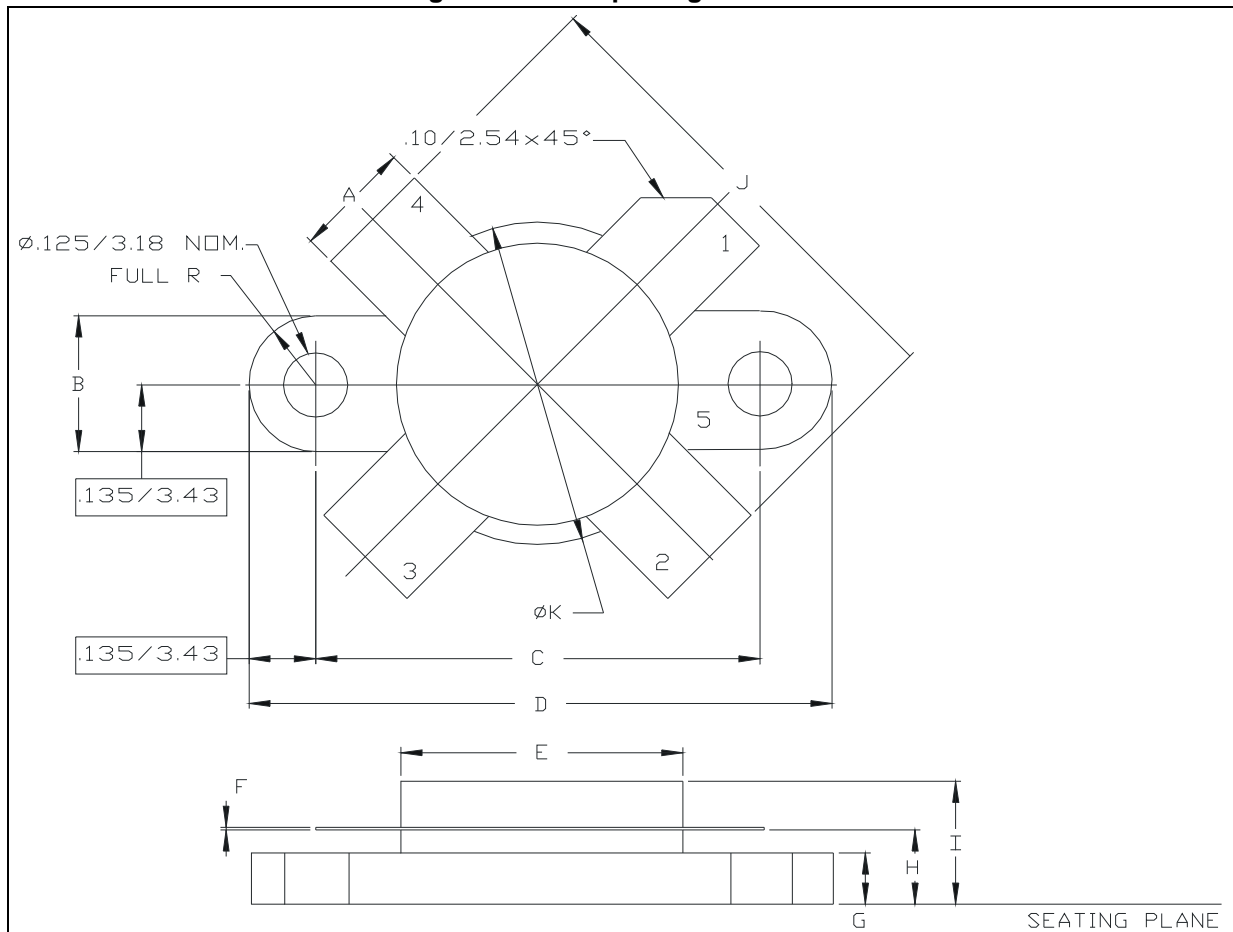

a. Controlling dimensions in inches.

Table 10. M177 (.500 dia 4/L N/HERM W/FLG) package mechanical data

Dim.	mm			Inch		
	Min.	Typ.	Max.	Min.	Typ.	Max.
A	5.72	-	5.97	0.225	-	0.235
B	6.73		6.96	0.265		0.275
C	21.84		22.10	0.860		0.870
D	28.70		28.96	1.130		1.140
E	13.84		14.10	0.545		0.555
F	0.08		0.18	0.003		0.007
G	2.49		2.74	0.098		0.108
H	3.81		4.32	0.150		0.170
I			7.11			0.280
J	27.43		28.45	1.080		1.120
K	15.88		16.13	0.625		0.635

6 Marking, packing and shipping specifications

Table 11. Packing and shipping specifications

Order code	Packaging	Pcs per tray	Dry pack humidity	GFS code	Lot code
SD2933W	Plastic tray	25	< 10%	Not mixed	Not mixed

Figure 19. Marking layout for SD2933W

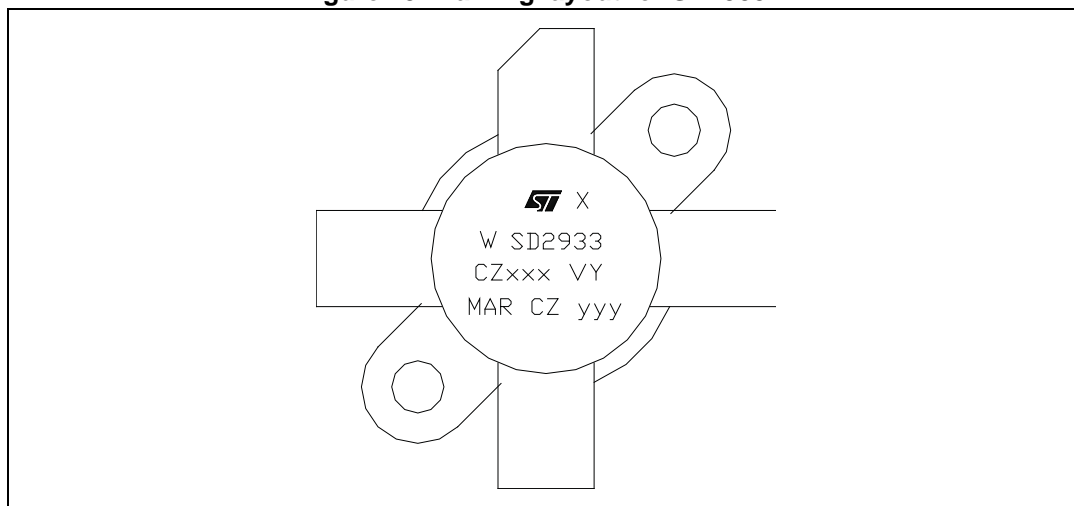

Table 12. Marking specifications

Symbol	Description
W	Wafer process code
X	G _{FS} sort
CZ	Assembly plant
xxx	Last 3 digits of diffusion lot
VY	Diffusion plant
MAR	Country of origin
CZ	Test and finishing plant
y	Assembly year
yy	Assembly week

7 Revision history

Table 13. Document revision history

Date	Revision	Changes
30-Jul-2004	9	
22-Sep-2011	10	Inserted <i>Section 6: Marking, packing and shipping specifications</i> . Updated EAS in <i>Table 2: Absolute maximum ratings</i> . Minor text changes to improve readability.
03-Oct-2011	11	Updated parameter Z_{IN} in <i>Table 7: Impedance data</i> .
17-Nov-2011	12	Inserted <i>Figure 7: Transient thermal impedance</i> and <i>Figure 8: Transient thermal impedance model</i> .
10-Jan-2012	13	Updated <i>Figure 7: Transient thermal impedance</i> .
30-Sep-2013	14	<ul style="list-style-type: none"> – Added row for “Avalanche energy, repetitive” and footnote to <i>Table 2: Absolute maximum ratings</i> – Minor text and formatting changes
14-Jul-2016	15	<ul style="list-style-type: none"> – Updated V_{GS} in <i>Table 2: Absolute maximum ratings</i>. – Minor text changes.

IMPORTANT NOTICE – PLEASE READ CAREFULLY

STMicroelectronics NV and its subsidiaries ("ST") reserve the right to make changes, corrections, enhancements, modifications, and improvements to ST products and/or to this document at any time without notice. Purchasers should obtain the latest relevant information on ST products before placing orders. ST products are sold pursuant to ST's terms and conditions of sale in place at the time of order acknowledgement.

Purchasers are solely responsible for the choice, selection, and use of ST products and ST assumes no liability for application assistance or the design of Purchasers' products.

No license, express or implied, to any intellectual property right is granted by ST herein.

Resale of ST products with provisions different from the information set forth herein shall void any warranty granted by ST for such product.

ST and the ST logo are trademarks of ST. All other product or service names are the property of their respective owners.

Information in this document supersedes and replaces information previously supplied in any prior versions of this document.

© 2016 STMicroelectronics – All rights reserved