

FIGURE B

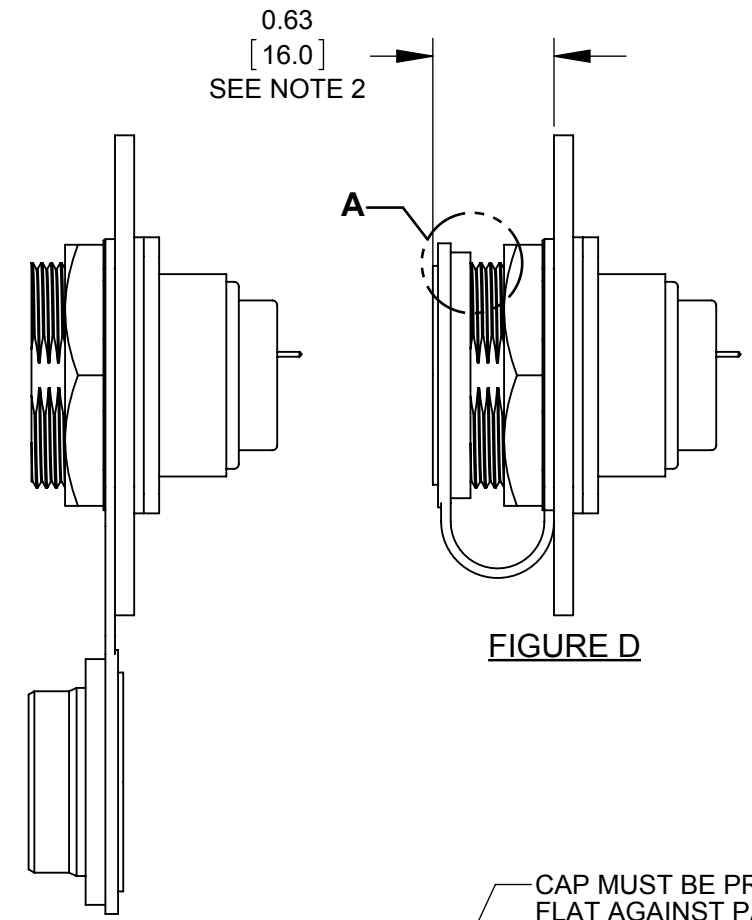
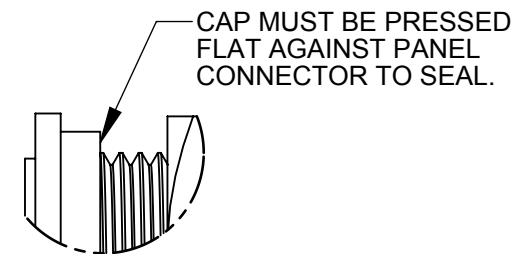
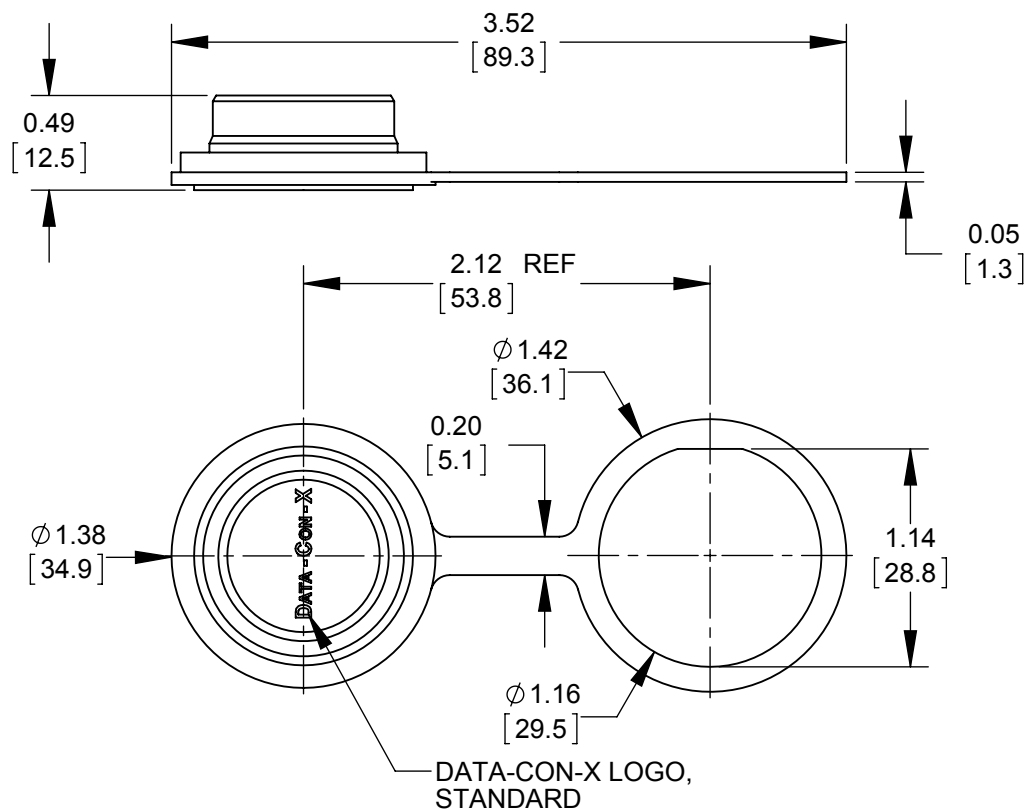

FIGURE C

FIGURE D



DETAIL A SCALE 2 : 1



DIMENSIONS SHOWN FOR REFERENCE ONLY

NOTES:

1. D24295-WA CONTAINS ONE SEAL CAP AND ONE FLAT WASHER.
2. THE DIMENSION DOES NOT INCLUDE GASKET COMPRESSION.
3. INSTALL SEAL CAP ON THE CONNECTOR AS SHOWN IN FIGURE A. HEX NUT RECOMMENDED TORQUE: 8-10 lb-in [0.90 - 1.13 N-m].
4. MATERIAL: SEAL CAP - THERMOPLASTIC ELASTOMER, BLACK
WASHER - MYLAR, WHITE
5. UNLESS OTHERWISE SPECIFIED TOLERANCES:
TWO PLACE DECIMALS ±0.02 [±0.5]

DIMENSIONS IN BRACKET [] ARE METRIC.

RoHS COMPLIANT

CUSTOMER DRAWING

0A	JGK	8/27/15	DRAWING CREATED FOR DATA-CON-X IP CAP.		
REV.	INIT.	DATE	DESCRIPTION		
	JGK	8/27/15	ORIG. DRAWN BY: DATE: 8/27/15		
ALL INFORMATION ILLUSTRATED IS THE PROPERTY OF CONXALL CORPORATION. UNAUTHORIZED DUPLICATION OR DISTRIBUTION OF THIS DOCUMENT IS PROHIBITED.			CHECKED BY:		
ALL UNITS ARE IN FEET, INCHES, FRACTION OF INCHES AND DECIMALS.			APPROVED BY:		
UNLESS OTHERWISE SPECIFIED TOLERANCES: 3 PLACE DECIMALS ±0.005 ANGLES ±1° FRACTIONS ±1/16			SCALE	SIZE	SHEET
UNLESS OTHERWISE SPECIFIED TOLERANCES: 3 PLACE DECIMALS ±0.005 ANGLES ±1° FRACTIONS ±1/16			1:1	B	1 OF 1
FILE: - CRITICAL CHARACTERISTIC FLAG PER SPEC. XXXX			FILE:	DIRECTORY:	PART NUMBER:
			SAME AS P/N	SLW	D24295-WA
					REV 0A



601 E. WILDWOOD VILLA PARK, IL 60181
TITLE: PANEL SEAL CAP
DATA-CON-X SERIES
IP RATED
CUSTOMER: STANDARD PRODUCT