AMP Novo Shunt Connector

1. SCOPE

1.1 Content

This specification covers the performance , tests and quality requirements for the **AMP Novo Shunt Connectors** . These connectors are mounted on .025 square or Round pins (0,635 mm) spaced at .100 inch pitch (2,54 mm) .

1.2 Qualification

When tests are performed on the subject product line, the procedures specified in TE 109 Series Specifications shall be used . All inspections shall be performed using the applicable inspection plan and product drawing .

2. APPLICABLE DOCUMENTS

The following documents form a part of this specification to the specified herein . In the event of conflict between the requirements of this specification and the product drawing , the product drawing shall take precedence . In the event of conflict between the requirements of this specification and the referenced documents , this specification shall take precedence .

2.1 TE Specifications

- 109-1 *General Requirements for Test Specifications .*
- 109 Series *Test Specification as indicated in Figure 1 (comply with MIL-STD-202, MIL-STD-1344 and EIA RS-364) .*
- Corporate Bulletin 76 *Cross Reference between TE Test Specifications and Military or Commercial Documents .*

2.2 Military Standard

- MIL-STD-275 *Printed Wiring for Electric Equipment .*

3. REQUIREMENTS

3.1 Design and Construction

Connectors shall off the design , construction and physical dimensions specified on the applicable product drawing .

3.2 Materials

- Contact : Phosphor Bronze, tin plated or gold plated version.
- Housing : Thermoplastic. Polyamide 6-6, 15% glass fiber.

3.3 Ratings

- Current : 3 A maximum.
- Operating Temperature : -40° C to 85° C.

3.4 Performance and Test Description

Connectors shall be designed to meet the electrical, mechanical and environmental performance requirements specified in Figure 1 .

3.5 Test Requirements and Procedures Summary

Test Description	Requirements	Procedures
Examination of product	Meets requirements of product drawing.	Visual, dimensional and functional per applicable inspection plan.
Electrical		
Termination resistance, rated current.	15 mΩ maximum.	Measure potential drop of mated contacts assembled in housing, see Fig. 3; IEC 60512-2-2, calculate resistance.
Termination resistance Dry Circuit (low level).	15 mΩ maximum.	Subject mated contacts assembled in housing to 20 mV open circuit at 100 ma maximum, see Fig. 3; IEC 60512-2-1.
Dielectric Withstanding Voltage	750 Vac, one minute hold connectors shall withstand without break down or flashover.	Test between adjacent contacts of mated connector assemblies: IEC 60512-4-1.
Insulation Resistance	Initial 5000 megaohms min. After test, 1000 MΩ min.	Test between adjacent contacts of mated connector assembly; EIA 364-21C
Mechanical		
Vibration (a)	No discontinuities greater than 1 microsecond.	Subject mated connector to 15 G's for tin-plated or gold-plated versions, 10-2000 Hz w/ 100 ma current applied; EIA 364-28D, method III.
Physical Shock (a)	No discontinuities greater than 1 microsecond.	Subject mated connector for 100 G's sawtooth in 6 milliseconds; 3 shocks in each direction applied along the three mutually perpendicular planes. Total: 18 shocks; EIA 364-27B, condition G.
Mating Force (on posts)	15 N max. (tin-plated version) 12 N max. (gold-plated version).	In the first insertion of the connector on two .025 posts (0,635 mm), measure force necessary to mate conn. ass'y from point of initial contact, incorporating free floating fixtures at a rate of 0,5 in/minute; EIA 364-13B.
Unmating Force (on posts)	1,5N minimum.	After one insertion of the conn. on two .025 posts (0,635 mm), measure force necessary to unmate conn. ass'y, at a rate of 0,5 in/minute; EIA 364-13B.
Contact engaging force	12N max.(Tin-plated version) 10N max.(Gold-plated version)	Measure force to engage using gage B, as indicated in Fig.4; TE Spec. 109-35; engagement depth 5,8mm min.
Contact separating force	0,5N minimum.	Size 3 times using gage B, as indicated in Fig.4, insert gage C and measure force to separate; TE Spec. 109-35.

cont.

Durability (on posts)	See note (a)	Mate and Unmate connector assemblies for 10 cycles/min. maximum. Number of operations 20 (Tin-plated); 50 (Gold-plated); IEC 60512-9-1.
Thermal Shock (a)	See note (a)	Subject mated connectors to 5 cycles between -40° C and 85° C ; EIA 364-32C.
Humidity, Steady State	See note (a)	Subject mated connectors to 10 days humidity temperature cycling at 40° C and 95% RH; EIA 364-31B method II, cond. B.
Corrosion Salt Spray	See note (a)	Subject mated connectors to 5% salt concentration for 48 hours; EIA 364-26B, cond. B.

Figure 1

(a) Shall remain mated and show no evidence of damage , cracking or chipping .

3.6 Connector Tests and Sequence

Test or Examination	Test Group (b)		
	1	2	3
	Test Sequence (c)		
Examination of product	1	1	1
Termination resistance, dry circuit	3,10	2,9	2,4
Termination resistance, rated current		10	5
Insulation resistance		3,6	
Dielectric withstanding voltage		4,7	
Connector mating force	2		
Connector unmating force	4		
Contact engaging force	5		
Contact separating force	6		
Durability	9		
Vibration	7		
Physical shock	8		
Humidity, Steady State		5	
Thermal shock			3
Corrosion, salt spray		8	

Figure 2

(b) See Paragraph 4.2.A.

(c) Numbers indicate sequence in which tests are performed .

4. QUALITY ASSURANCE PROVISIONS

4.1 General Requirements

Connectors presented under this Specification shall be a product which has a passed qualification tests per Paragraph 4.2 and which meets the Quality Assurance requirements of Paragraph 4.3 .

4.2 Qualification Requirements

a) Sample Selection

Connector housings and contacts shall be prepared in accordance with applicable instruction sheets . They shall be selected at random from current production . Each test group 1 , 2 and 3 shall consist of a minimum of six connectors .

b) Test Sequence

Qualification Inspection shall be verified by testing samples as specified in Figure 2 .

c) Acceptance

- (1) All samples tested in accordance with this Specification shall meet the stated tolerance limit.
- (2) Failures attributed to equipment , Test Set-up or operator deficiencies shall not disqualify the product . When product failure occurs , corrective action shall be taken and samples resubmitted for qualification .

4.3 Quality Conformance Inspection

The applicable TE Inspection Plan will specify the sampling acceptable quality level to be used . Dimensional and functional requirements shall be in accordance with the applicable product drawing and this specification .

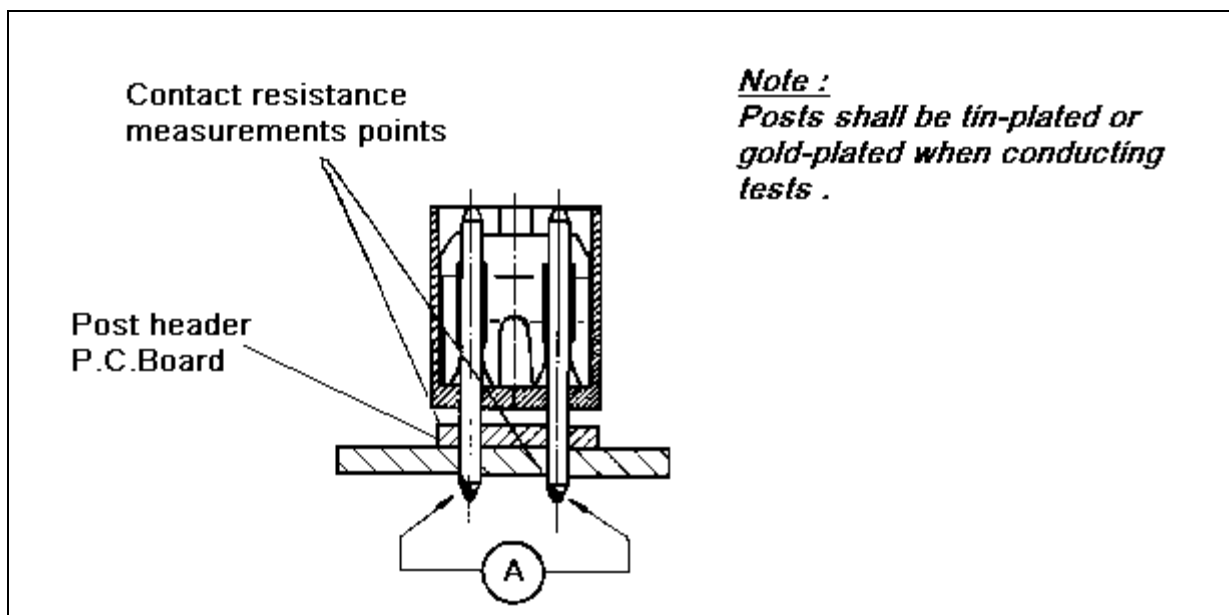
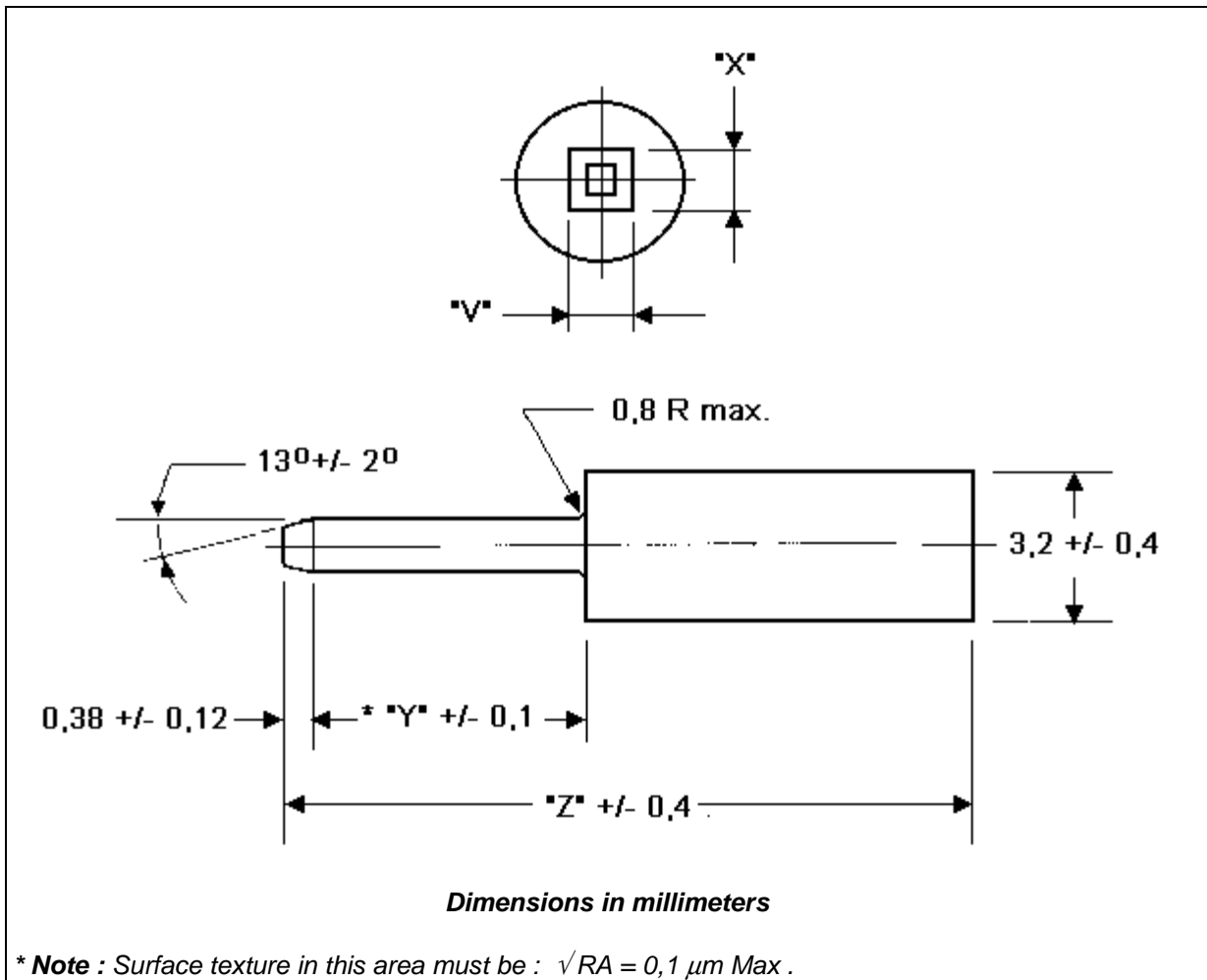

Figure 3



	Post dimensions	V	X	Y	Z
"B" insertion	0,635 x 0,635	0,660 + 0,000 / - 0,002	0,660 + 0,000 / - 0,002	8,25	31,7
"C" separation	0,635 x 0,635	0,610 + 0,002 / - 0,000	0,610 + 0,002 / - 0,000	8,25	31,7

Figure 4

Rev.	Date	History Changes Description	Prepared	Approved
D	04-May-2011	Changed Items 3.5 and 3.6	H.Canteri	W.Stefani