

1210

Standard

SPECIFICATIONS

- ◆ **PC Board Mountable Pressure Sensor**
- ◆ **0-100 mV Output**
- ◆ **Current Excitation**
- ◆ **Gage, Absolute, and Differential**
- ◆ **Temperature Compensated**

The 1210 is a temperature compensated, piezoresistive silicon pressure sensor packaged in a dual-in-line configuration. It is intended for cost sensitive applications where excellent performance and long-term stability are required.

Integral temperature compensation is provided over a range of 0-50°C using laser-trimmed resistors. An additional laser-trimmed resistor is included to normalize pressure sensitivity variations by programming the gain of an external differential amplifier. This provides sensitivity interchangeability of $\pm 1\%$. Gage, absolute, and differential pressure ranges from 0-2 psi to 0-100 psi are available. Multiple lead and tube configurations are available for specific applications.

Please refer to the 1210 1 psi datasheet for low pressure applications. For voltage excitation, please refer to the Model 1220.

FEATURES

- ◆ Dual-in-Line Package
- ◆ 0°C to 50°C Compensated Temperature Range
- ◆ ±0.1% Non-Linearity
- ◆ 1.0% Interchangeable Span (provided by gain set resistor)
- ◆ Solid State Reliability

APPLICATIONS

- ◆ Medical Instruments
- ◆ Airspeed and Altitude Measurements
- ◆ Process Control
- ◆ Factory Automation
- ◆ Vacuum Measurement
- ◆ Handheld Calibrators

STANDARD RANGES

Range	psia	psid	psig	Port Styles
0 to 2		◆	◆	S, L, N, B*
0 to 5	◆	◆	◆	S, L, N, B*
0 to 15	◆	◆	◆	S, L, N
0 to 30	◆	◆	◆	S, L, N,
0 to 50	◆	◆	◆	S, L, N
0 to 100	◆	◆	◆	S, L, N

*Barb port styles are only available in lead configuration type 3. See Ordering Information.

PERFORMANCE SPECIFICATIONS

Supply Current: 1.5mA

Ambient Temperature: 25°C (unless otherwise specified)

PARAMETERS	MIN	TYP	MAX	UNITS	NOTES
Span	75	100	150	mV	1
Span (2 psi version)	30		60	mV	1
Zero Pressure Output	-2		2	mV	
Pressure Non Linearity	-0.1	±0.05	0.1	%Span	2
Pressure Hysteresis	-0.05	±0.01	0.05	%Span	
Input & Output Resistance	2500	4400	6000	Ω	
Temperature Error – Span	-0.5	±0.3	0.5	%Span	3
Temperature Error – Zero	-0.5	±0.1	0.5	%Span	3
Thermal Hysteresis – Zero		±0.1		%Span	3
Supply Current		1.5	2.0	mA	
Response Time (10% to 90%)		1.0		ms	4
Output Noise (10Hz to 1kHz)		1.0		μV p-p	
Long Term Stability (Offset & Span)		±0.1		%Span	5
Pressure Overload			3X	Rated	6
Compensated Temperature	0		50	°C	
Operating Temperature	-40		+125	°C	
Storage Temperature	-50		+150	°C	
Weight			3	grams	
Solder Temperature	250°C Max 5 Sec.				
Media	Non-Corrosive Dry Gases Compatible with Silicon, Pyrex, RTV, Gold, Ceramic, Nickel, and Aluminum				

Notes

1. Ratiometric to supply current.
2. Best fit straight line.
3. Maximum temperature error between 0°C and 50°C with respect to 25°C. For 2psi devices, Temperature Error -- Zero is ±1%.
4. For a zero-to-full scale pressure step change.
5. Long term stability over a one year period with constant current and temperature.
6. 2X maximum for 100psi device. 20psi maximum for 2 and 5psi devices.

DIMENSIONS

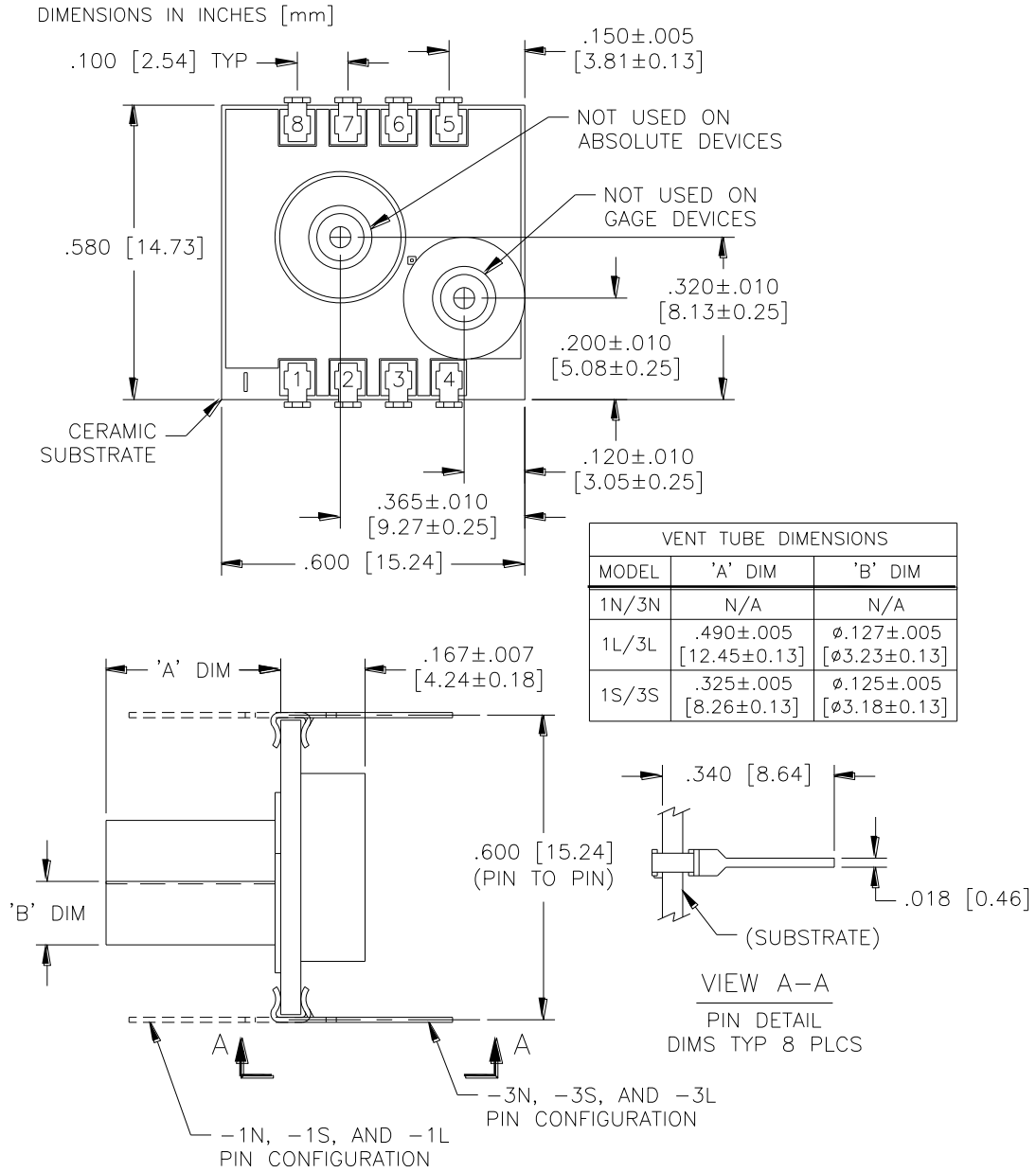

BARB DIMENSIONS

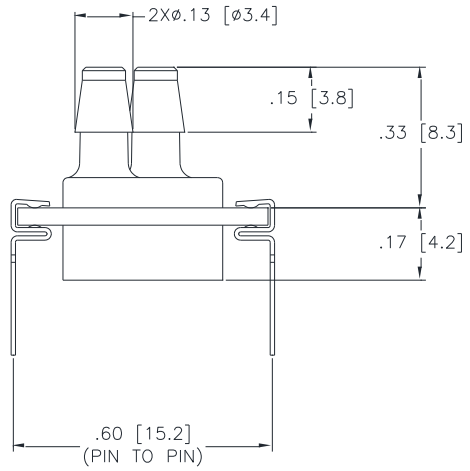
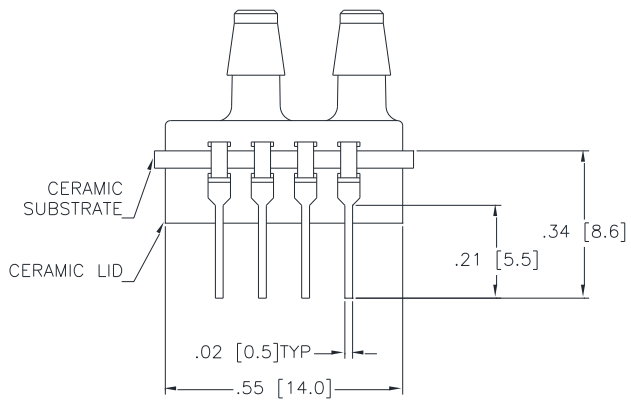
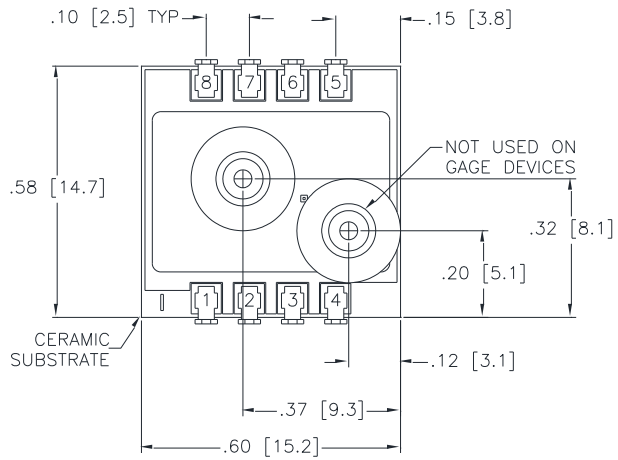

CONNECTIONS

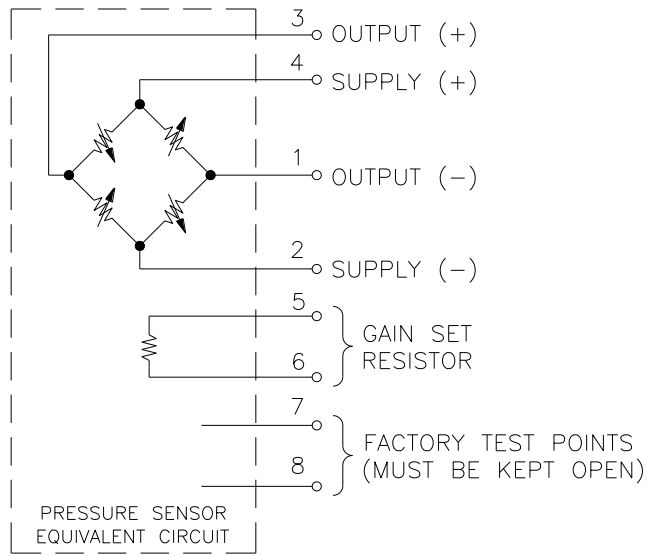

APPLICATION SCHEMATIC

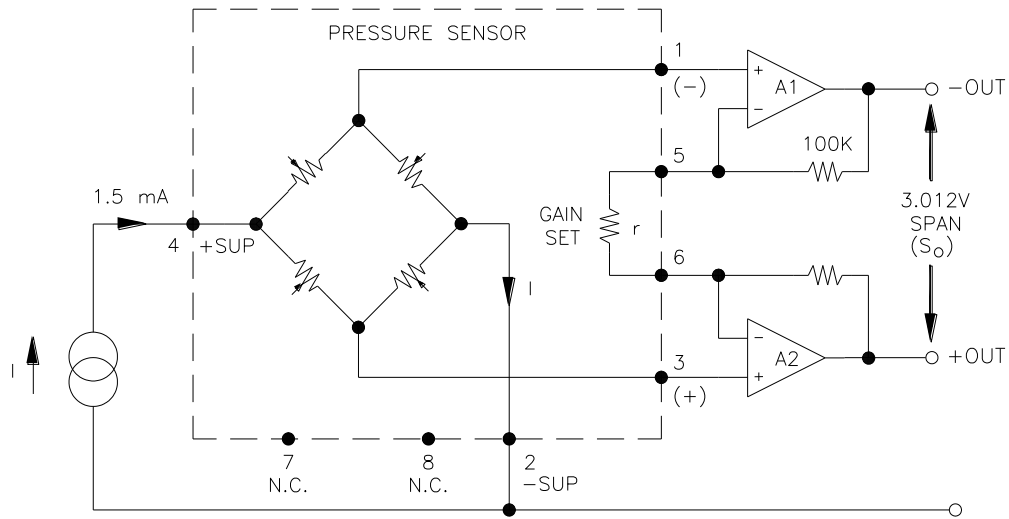

APPLICATION SCHEMATIC

ORDERING INFORMATION

1210A – 030 A – 3 B

Pressure Range [psi]	
	015
	030
	050
	100

Pressure Type	
G	Gage
A	Absolute
D	Differential

Vent	
L	Long Tube
S	Short Tube
N	No Tube
B	Barb

Fitting Type	
3	Opposite Side as Vent Tube
1	Same Side as Vent Tube

Barb port styles are only available in lead configuration type 3.

NORTH AMERICA

Measurement Specialties, Inc.,
a TE Connectivity company
Tel: 800-522-6752
customercare.fmt@te.com

TE.com/sensorsolutions

Measurement Specialties, Inc., a TE Connectivity company.

Measurement Specialties, TE Connectivity, TE Connectivity (logo) and EVERY CONNECTION COUNTS are trademarks. All other logos, products and/or company names referred to herein might be trademarks of their respective owners.

The information given herein, including drawings, illustrations and schematics which are intended for illustration purposes only, is believed to be reliable. However, TE Connectivity makes no warranties as to its accuracy or completeness and disclaims any liability in connection with its use. TE Connectivity's obligations shall only be as set forth in TE Connectivity's Standard Terms and Conditions of Sale for this product and in no case will TE Connectivity be liable for any incidental, indirect or consequential damages arising out of the sale, resale, use or misuse of the product. Users of TE Connectivity products should make their own evaluation to determine the suitability of each such product for the specific application.

© 2015 TE Connectivity Ltd. family of companies All Rights Reserved.

EUROPE

MEAS Switzerland Sarl,
a TE Connectivity company
Tel: 800-440-5100
customercare.bevx@te.com

ASIA

Measurement Specialties (China) Ltd.,
a TE Connectivity company
Tel: 0400-820-6015
mailto:customercare.shzn@te.com