

REVISONS		DATE	OWN	APVD
P	LTR	DESCRIPTION		
E	REV PER ECO	08-026286	10-22-08	CT RL

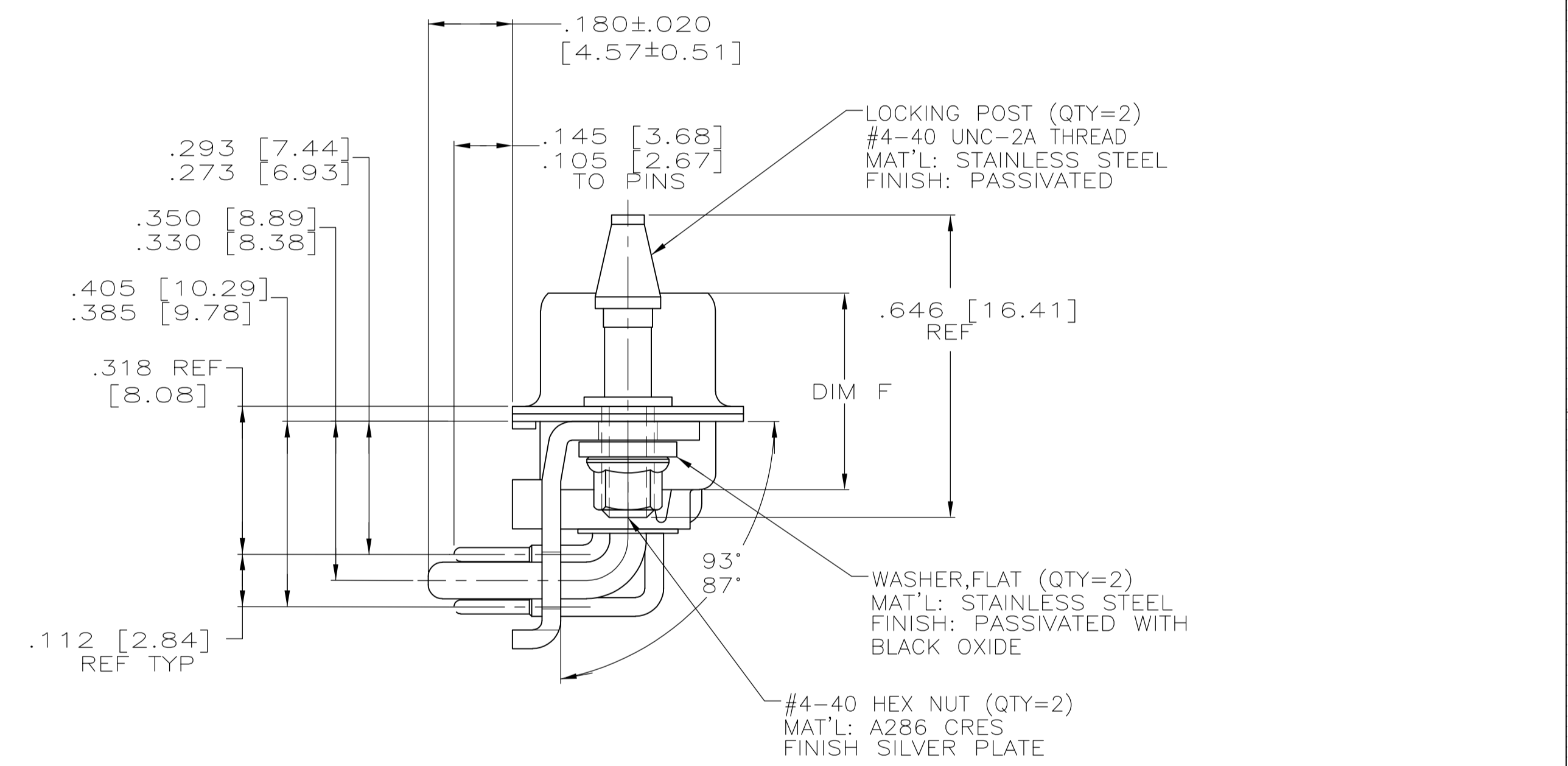
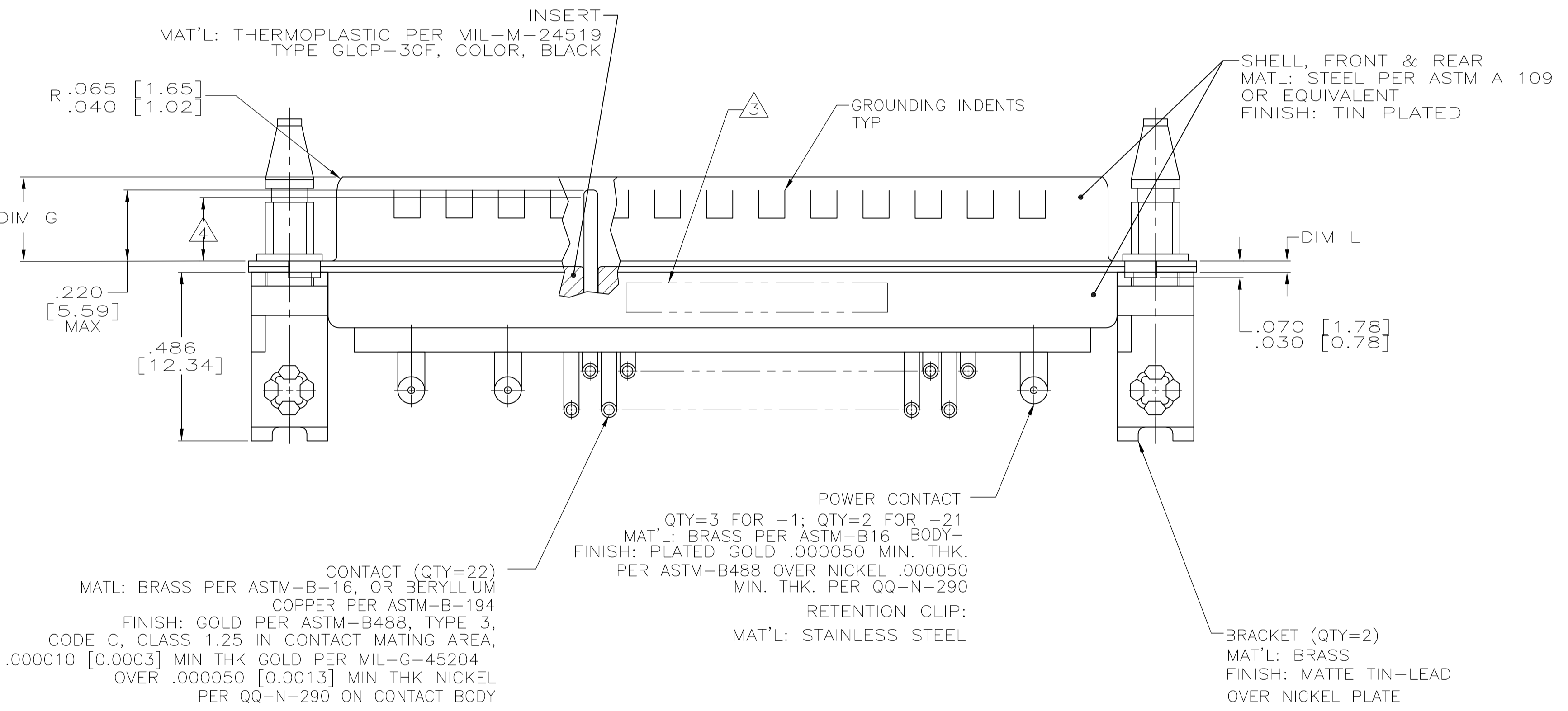
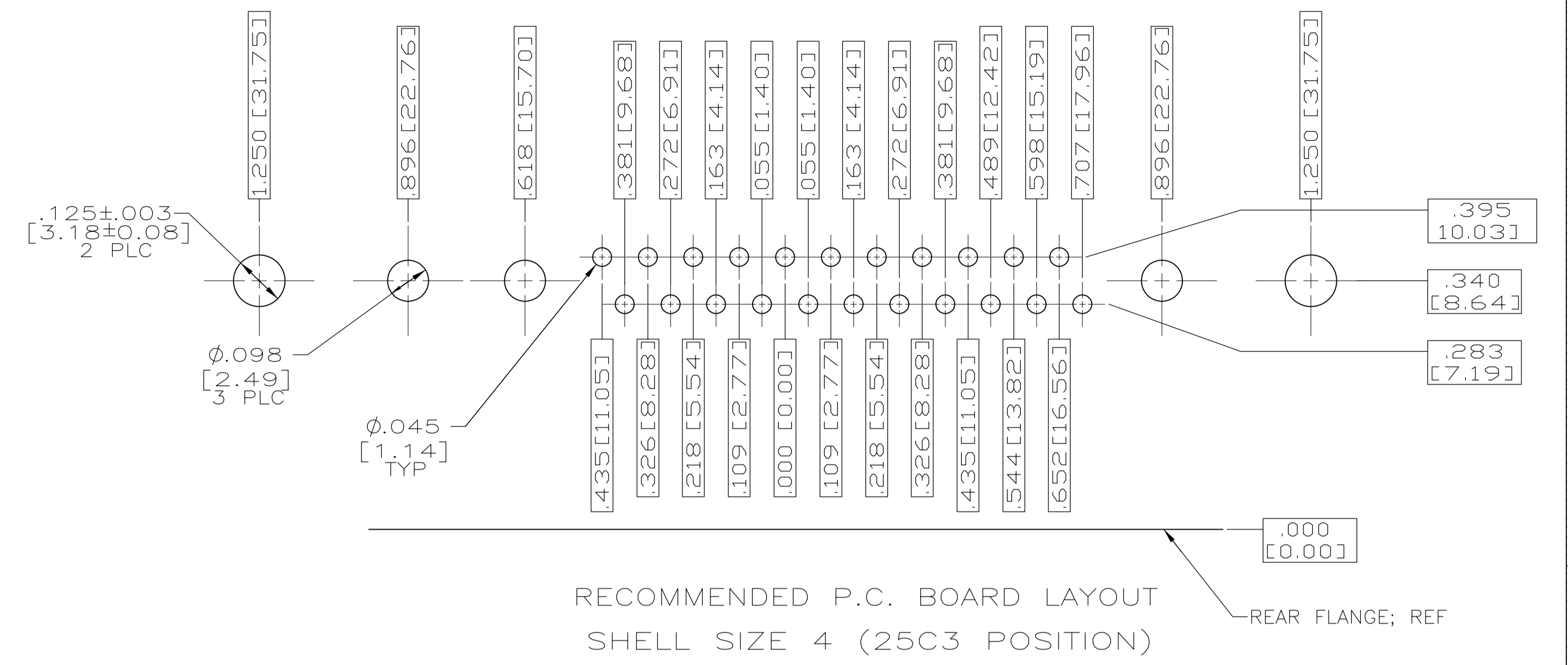
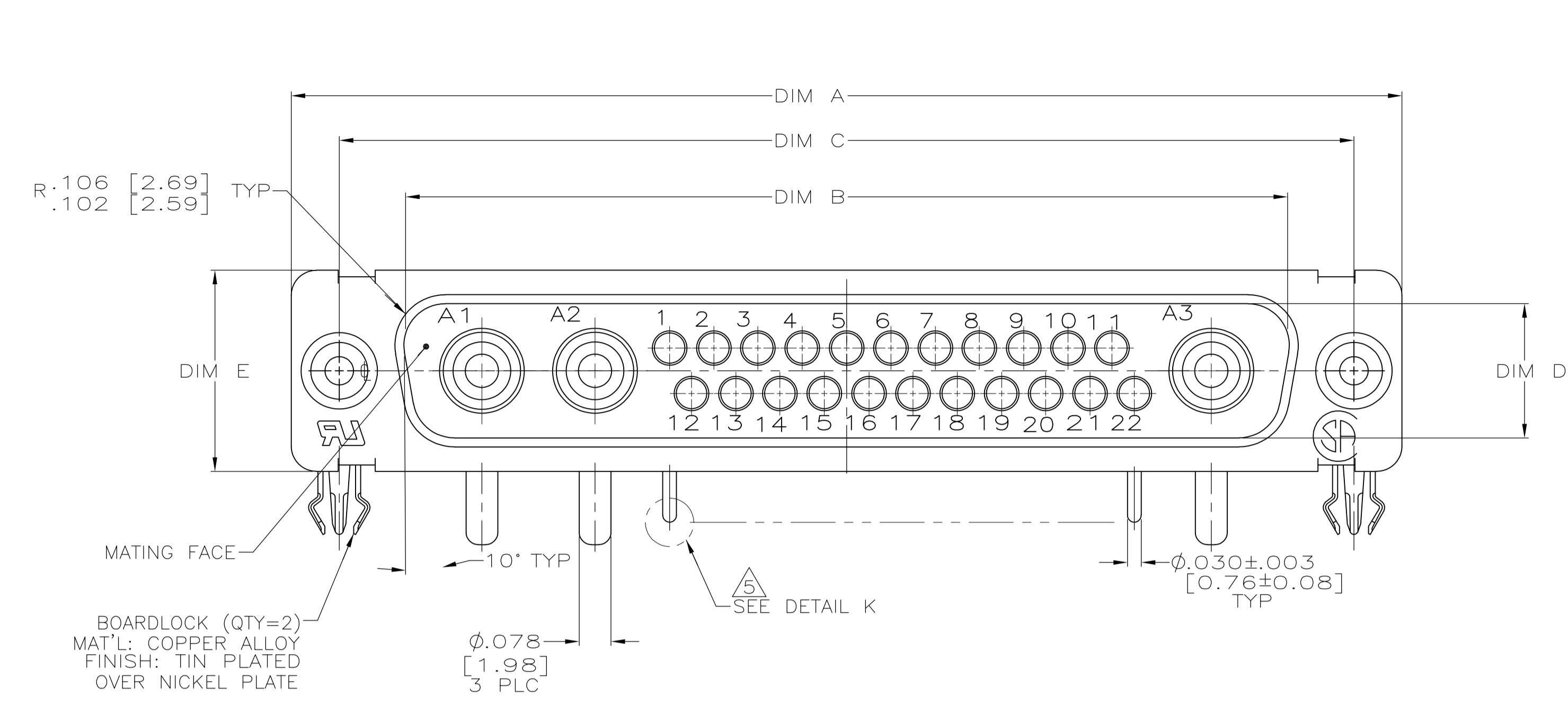

- 1 TRUE POSITION TOLERANCE FOR P.C. BOARD LAYOUT IS .010 [0.25] AT MAX MATERIAL CONDITION. SUGGESTED BOARD THICKNESS IS .077±.005 [1.96±0.13].
- 2 THE CONNECTOR DESCRIBED IN THIS DOCUMENT WILL MATE WITH ANY RECEPTACLE CONNECTOR WITH THE SAME INSERT ARRANGEMENT.
- 3 MARKED WITH .047 [1.19]-.062 [1.57] HIGH CHARACTERS. FAR SIDE REFERS TO THE WIDE SIDE OF THE KEYSTONE. NEAR SIDE REFERS TO THE NARROW SIDE OF THE KEYSTONE. MARKED AS FOLLOWS:  
MANUFACTURER'S NAME, LOGO OR BRAND NAME, PART NO. AND DATE CODE ON REAR SHELL, FAR SIDE
- 4 REQUIREMENT FOR FULL PIN DIAMETER EXTENSION:  
.159 [4.04] MIN FOR SHELL SIZE 1
- 5 POWER 8 & SIGNAL CONTACTS ARE SOLDER DIPPED WITH SnPb 63/37 TO MEET THE REQUIREMENTS OF MIL-STD-202, METHOD 208.

PRELIMINARY NOT RELEASED FOR PRODUCTION

DETAIL K  
SCALE 8:1  
TYP

.049 [1.24]	.236 [5.99]	.436 [11.07]	.509 [12.93]	.334 [8.48]	2.505 [63.63]	2.187 [55.55]	2.744 [69.70]	25C3	4	2-1218611-1
.029 [0.74]	.224 [5.69]	.416 [10.57]	.479 [12.17]	.324 [8.23]	2.495 [63.37]	2.177 [55.30]	2.714 [68.94]	25C3	4	1218611-1
.049 [1.24]	.236 [5.99]	.436 [11.07]	.509 [12.93]	.334 [8.48]	2.505 [63.63]	2.187 [55.55]	2.744 [69.70]			
.029 [0.74]	.224 [5.69]	.416 [10.57]	.479 [12.17]	.324 [8.23]	2.495 [63.37]	2.177 [55.30]	2.714 [68.94]			
DIM L	DIM G	DIM F	DIM E	DIM D	DIM C	DIM B	DIM A	NO OF POS	SHELL SIZE	AMP PART NO.

THIS DRAWING IS A CONTROLLED DOCUMENT.

DIMENSIONS: INCHES [mm]

TOLERANCES UNLESS OTHERWISE SPECIFIED:

0 PLC	± .005
1 PLC	± .005
2 PLC	± .005
3 PLC	± .005
4 PLC	± .005
ANGLES	± .1°

MATERIAL: SEE CALLOUTS

FINISH: SEE CALLOUTS

WEIGHT: —

SIZE: A1

CAGE CODE: 00779

DRAWING NO: 1218611

RESTRICTED TO: —

CUSTOMER DRAWING

SCALE: 4:1

SHEET: 1 OF 2

REV: E

LOC		DIST		REVISIONS			
P	LTR	DESCRIPTION	DATE	DNW	APVD		
-	-	SEE SHEET #1	-	-	-	-	-

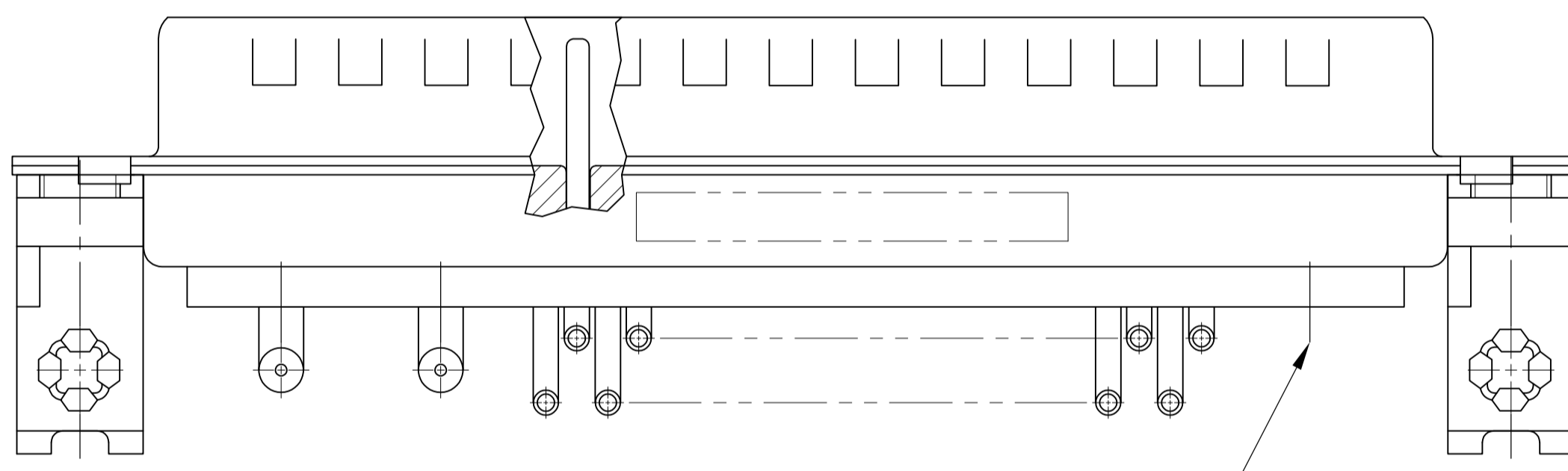

POWER CONTACT IN POSITION A3 NOT INCLUDED

CLINCH NUTS 4-40 UNC  
 MATL: STEEL PER ASTM A 109  
 FINISH: CLEAR CHROMATE OVER ZINC

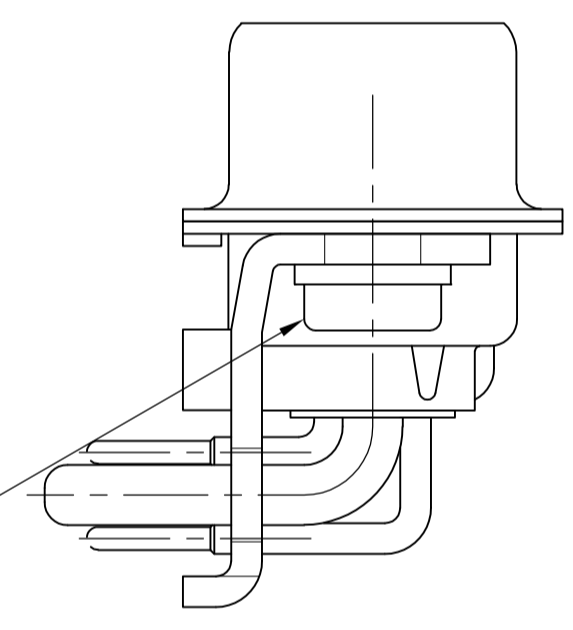

SHELL SIZE 4  
 CONTACT CONFIGURATION  
 VIEW SHOWN  
 WITHOUT BOARDLOCK  
 VIEW FOR 2--1 ONLY

VIEW FOR 2-1218611-1 ONLY  
 SAME AS -1 EXCEPT AS SHOWN

PRELIMINARY NOT RELEASED FOR PRODUCTION

THIS DRAWING IS A CONTROLLED DOCUMENT.		DNW C.C.THOMAS 1-10-00	Tyco Electronics Corporation Harrisburg, PA 17105-3608	
DIMENSIONS: INCHES [mm]		CHK D.MILLER 1-10-00	NAME D.MILLER 1-10-00	
TOLERANCES UNLESS OTHERWISE SPECIFIED:		PRODUCT SPEC		
APPLICATION SPEC		RESTRICTED TO		
MATERIAL SEE CALLOUTS		WEIGHT -	SIZE A1	CAGE CODE 00779
FINISH SEE CALLOUTS		DRAWING NO 1218611		REV E
CUSTOMER DRAWING		SCALE 4:1	SHEET 2 OF 2	