

USABLE WITH TAB 0.8mm AND TAB 0.6mm THICKNESS
Verwendbar mit Flachstecker 0.8mm und 0.6mm Dicke

LOC	DIST	REVISONS	DATE	OWN	APVD
A1	-	DESCRIPTION			
PROJ. NR.	C 12	ECR-15-001434	02FEB2015	SG	RL
	C 13	ECR-15-010777	20JUL2015	SG	RL
	C 14	ECR-15-012070	22SEP2015	JB, JH	BK
	C 15	ECR-15-017391	30NOV2015	SG	RL

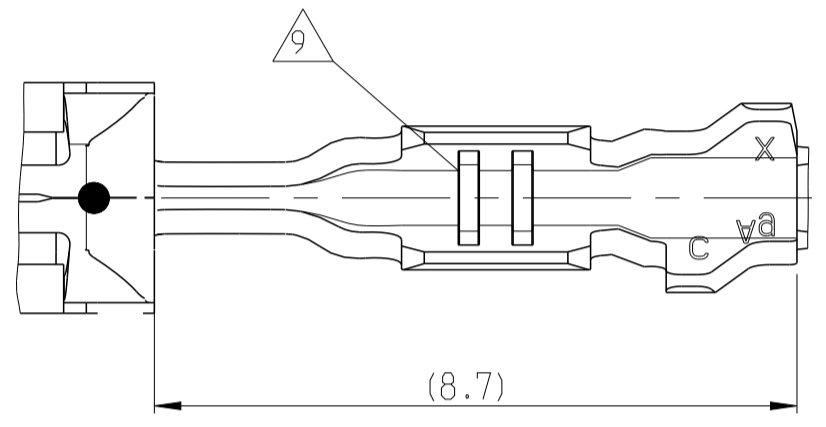
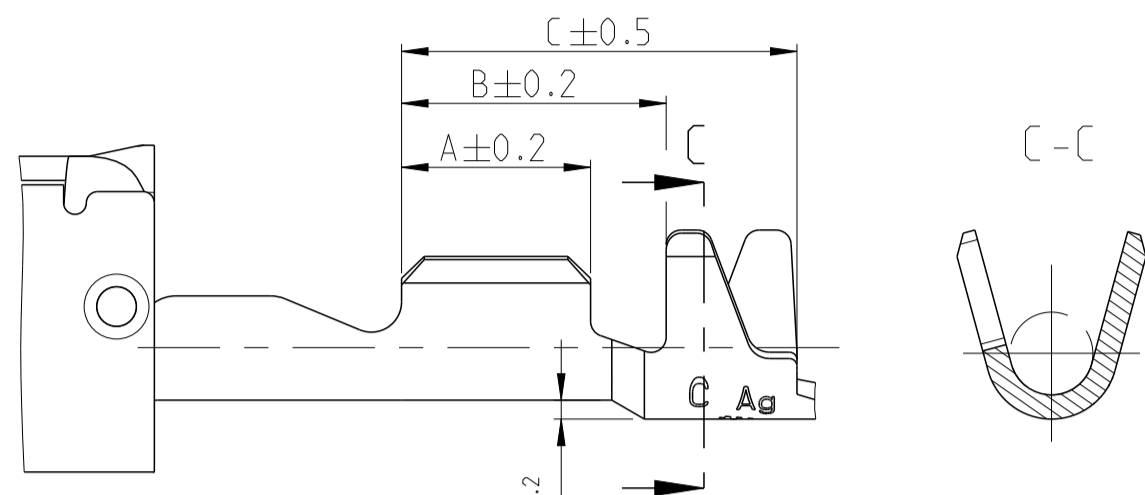
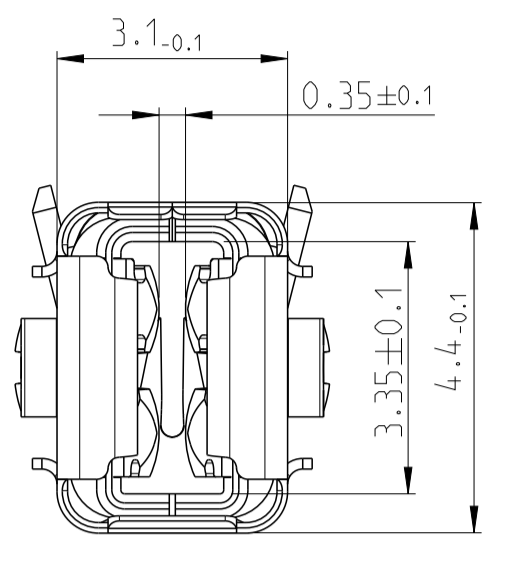
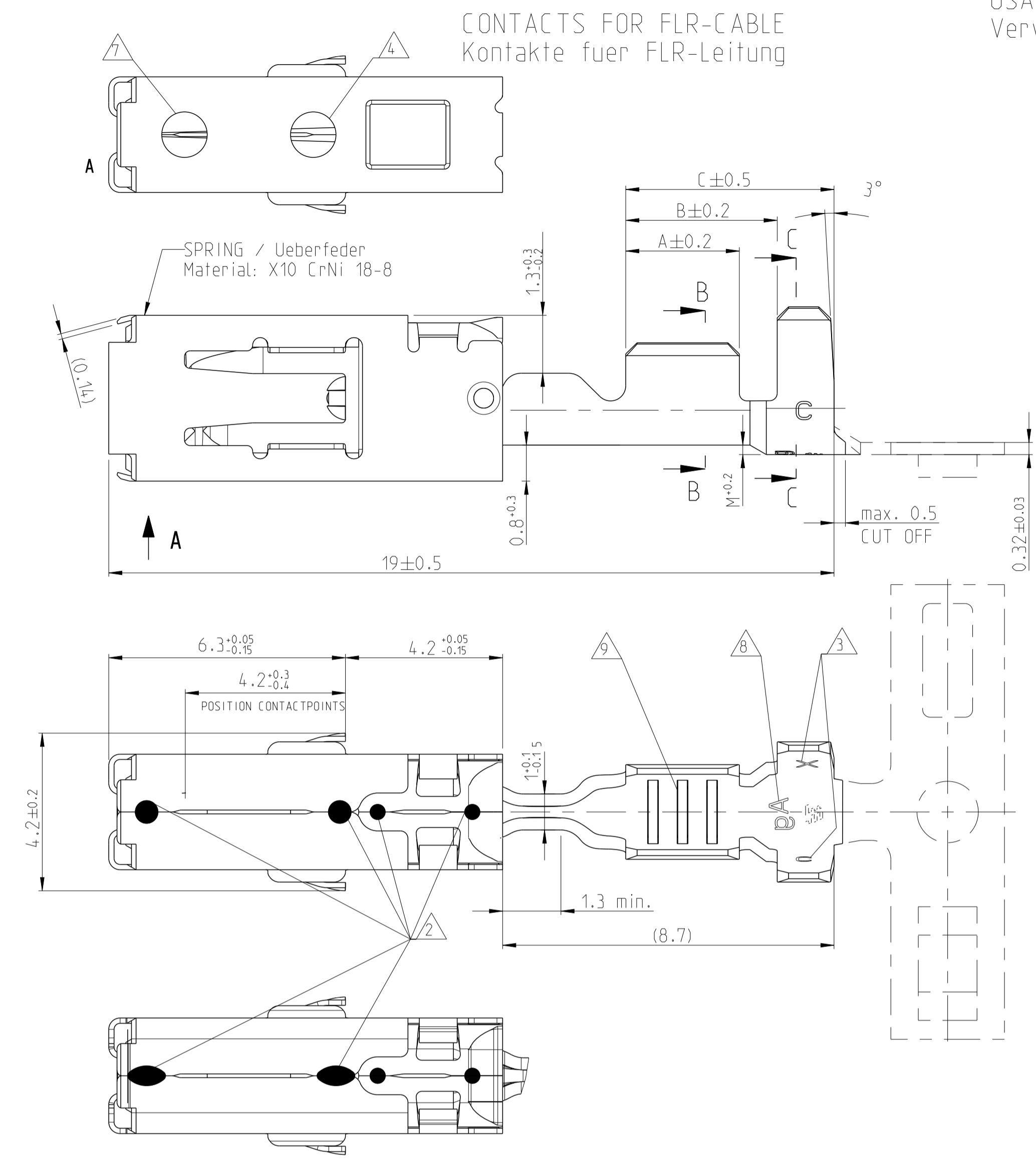

CONTACTS FOR SINGLE WIRE SEALING SYSTEM: FLR- AND FLK- CABLE
Kontakte fuer Einzel-Dichtung-System: FLR- und FLK-Leitung

DIMENSIONS SEE FIGURE "CONTACTS FOR FLR-CABLE"
Masse siehe Darstellung der Kontakte fuer FLR-Leitung

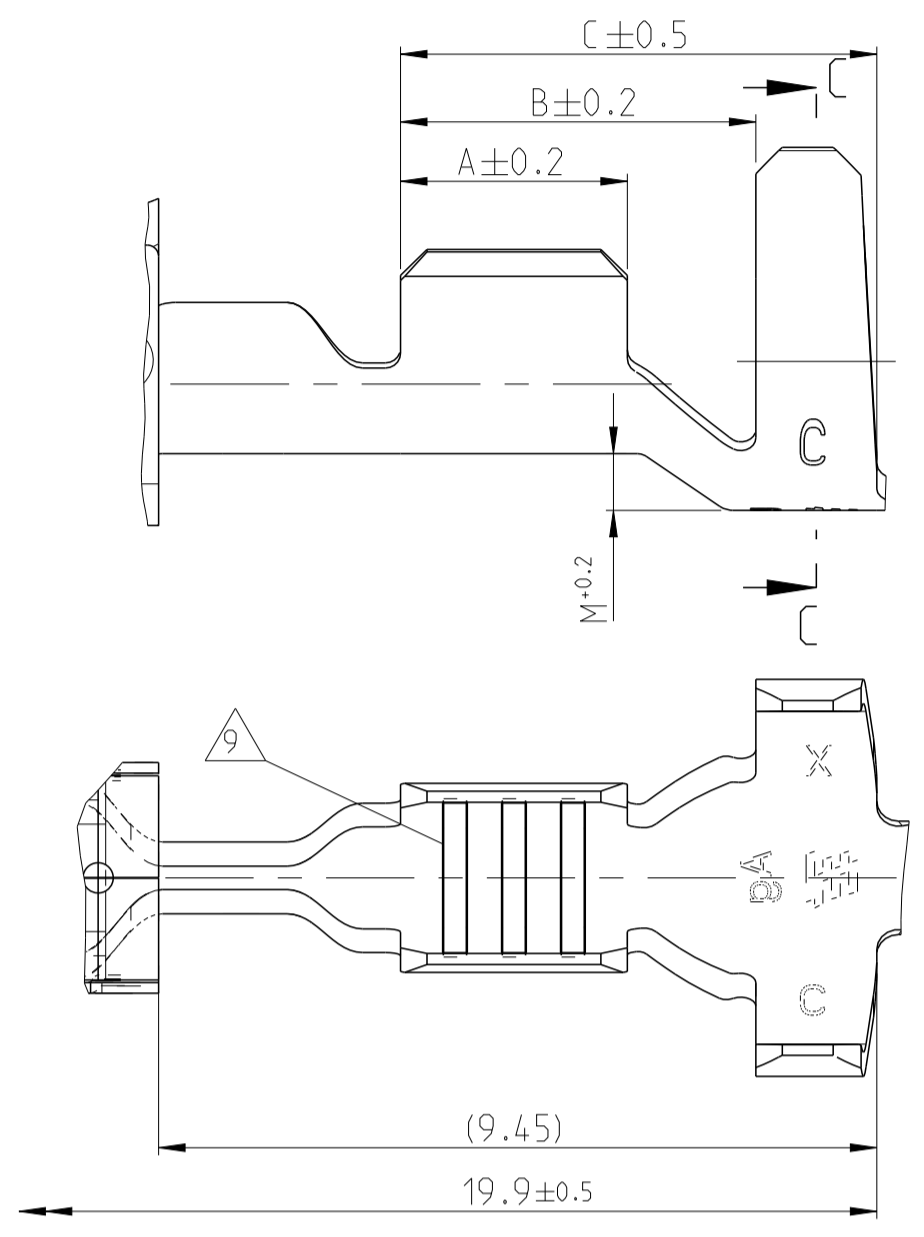

TYPE A

TYPE B

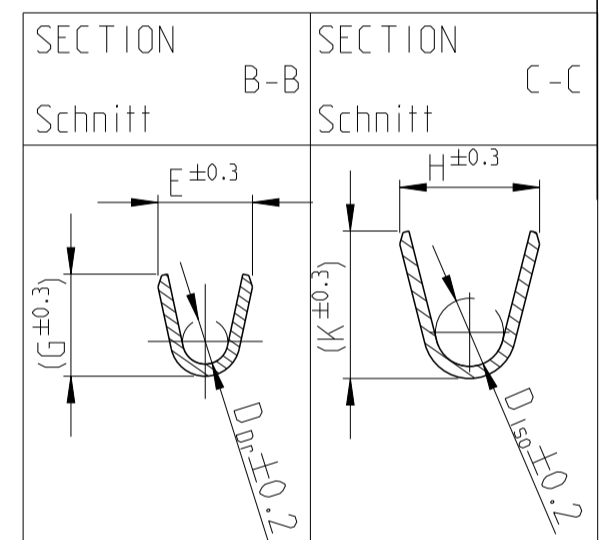

SINGLE WIRE SEALING SYSTEM

ORDER NO. Bestell-Nr.	INSULATION DIA Isolations Ø	COLOUR Farbe
963292-1	2.7...3.0	YELLOW gelb
963293-1	2.0...2.7	REDBROWN rotbraun
963294-1	1.2...2.1	BLUE blau

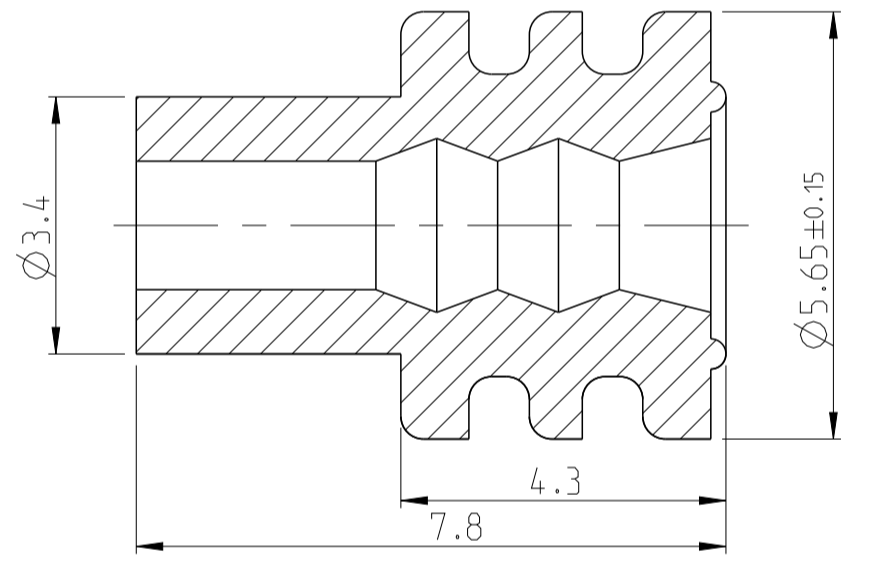

ORDER NO. Bestell-Nr.	REV.	WIRE RANGE Drahtgroessenbereich (mm²)	INSULATION DIA Isolations Ø (mm)	MATERIAL Werkstoff	PLATING Ueberzug	LENGTH Laenge	WIRE CRIMP Drahtcrimp	INSUL. CRIMP Isol.-Crimp	ORDER NO. Bestell-Nr. TOOL / INSERT Handzange / Matrize	ORDER NO. Bestell-Nr. EXTRACTION TOOL Ausdrueckwerkzeug	CRIMP DATA AND CRIMP TOOL Crimpdaten u. Crimpwerkzeuge
0-1241396-4	C	>1.0-2.5	2.2-3.0	CuNiSi	SILVERPLATED versilbert	A = 3.5 B = 5.2 C = 6.8	E = 3.6 G = 3.8 D_dr = 1.8	H = 5.45 K = (4.8) D_iso = 3.5 M = 0.85	HANDCRIMP TOOL Handcrimpwerkzeug 539635-1	INSERT / Matrize 539952-2	539969-1
2-1241396-3	C			CuNiSi	PRESILVER vorversilbert						
0-1241396-3	C			CuNiSi	PRESILVER vorversilbert						
0-1241396-2	C	0.5-1.0	1.4-2.7	CuNiSi	TINPLATED vorverzinkt	A = 3.0 B = 4.7 C = 6.3	E = 2.5 G = 2.7 D_dr = 1.2	H = 5.25 K = (4.8) D_iso = 3.3 M = 0.75	HANDCRIMP TOOL Handcrimpwerkzeug 539635-1	INSERT / Matrize 539952-2	539969-1
0-1241394-3	C			CuNiSi	PRESILVER vorversilbert						
0-1241394-2	C			CuNiSi	TINPLATED vorverzinkt						
0-1241394-1	C	0.2-0.35	1.1-1.4	CuNiSi	PRESILVER vorversilbert	A = 2.5 B = 4.7 C = 6.3	E = 1.9 G = 1.9 D_dr = 0.75	H = 4.85 K = (4.4) D_iso = 3.2 M = 0.7	HANDCRIMP TOOL Handcrimpwerkzeug 539635-1	INSERT 4-1579016-1	539969-1
0-1241392-3	C			CuNiSi	TINPLATED vorverzinkt						
0-1241392-2	C			CuNiSi	PRESILVER vorversilbert						
0-1241392-1	C	0.2-0.35	1.1-1.4	CuNiSi	TINPLATED vorverzinkt	A = 3.3 B = 4.3 C = 5.8	E = 2.4 G = 2.3 D_dr = 1.0	H = 4.7 K = (4.9) D_iso = 2.6 M = 0.4	HANDCRIMP TOOL Handcrimpwerkzeug 539635-1	INSERT / Matrize 539951-2	539969-1
0-1564984-3	C			CuNiSi	PRESILVER vorversilbert						
0-1564984-2	C			CuNiSi	TINPLATED vorverzinkt						
0-1564984-1	C	>1.0-2.5	2.2-3.0	CuNiSi	PRESILVER vorversilbert	A = 3.0 B = 4.0 C = 5.5	E = 2.5 G = 2.7 D_dr = 1.2	H = 3.7 K = (3.9) D_iso = 1.8 M = 0.2	HANDCRIMP TOOL Handcrimpwerkzeug 539635-1	INSERT / Matrize 539951-2	539969-1
0-1241390-3	C			CuNiSi	PRESILVER vorversilbert						
0-1241390-2	C			CuNiSi	TINPLATED vorverzinkt						
0-1241388-3	C	0.5-1.0	1.4-2.1	CuNiSi	PRESILVER vorversilbert	A = 2.5 B = 3.5 C = 5.2	E = 1.9 G = 1.9 D_dr = 0.75	H = 2.5 K = (2.5) D_iso = 1.1 M = 0.2	HANDCRIMP TOOL Handcrimpwerkzeug 539635-1	INSERT 4-1579016-1	539969-1
0-1241388-2	C			CuNiSi	TINPLATED vorverzinkt						
0-1241388-1	C			CuNiSi	PRESILVER vorversilbert						
0-1241386-3	C	0.2-0.35	1.1-1.4	CuNiSi	PRESILVER vorversilbert	A = 2.5 B = 3.5 C = 5.2	E = 2.4 G = 2.3 D_dr = 1.0	H = 2.5 K = (2.5) D_iso = 1.1 M = 0.2	HANDCRIMP TOOL Handcrimpwerkzeug 539635-1	INSERT 4-1579016-1	539969-1
0-1241386-2	C			CuNiSi	TINPLATED vorverzinkt						
0-1241386-1	C			CuNiSi	PRESILVER vorversilbert						
0-1564982-3	C	0.2-0.35	1.1-1.4	CuNiSi	PRESILVER vorversilbert	A = 2.5 B = 3.5 C = 5.2	E = 2.4 G = 2.3 D_dr = 1.0	H = 2.5 K = (2.5) D_iso = 1.1 M = 0.2	HANDCRIMP TOOL Handcrimpwerkzeug 539635-1	INSERT 4-1579016-1	539969-1
0-1564982-2	C			CuNiSi	TINPLATED vorverzinkt						
0-1564982-1	C			CuNiSi	PRESILVER vorversilbert						

SEE APPLICATION SPECIFICATION 114-18387

- TO BE USED ON Flachstecker / TAB 2.8 ±0.3 x 0.6 ±0.07
Geeignet fuer Flachstecker / TAB 2.8 ±0.3 x 0.8 ±0.03
- ALTERNATIVELY LASERWELDED POINT OR LINE SHAPED (DIE CAUSED). Laserschweissung wahlweise Punkt- oder Linienfoermig (Fertigungsbedingt)
- DIE-IDENTIFICATION AND REVISION STATUS Kennung fuer Werkzeug und Revisionsstand
- MIN. 0.8µm GOLDPLATE IN CONTACT AREA OVER MIN. 1.3µm NICKELPLATE; MIN. 1µm TINPLATE IN CRIMP AREA. AS INDEX SEE HOLE AT SPRING. 0.8µm Goldueberzug im Kontaktbereich ueber min. 1.3µm Nickelueberzug; min. 1µm Zinnueberzug im Crimpbereich. Zur Kennzeichnung siehe Loch an der Ueberfeder
- FOR DOUBLE AND SINGLE CRIMP Fuer Doppel- und Einzelcrimp
- SINGLE WIRE SEAL TO BE SELECTED ACCORDING TO INSULATION-DIA Auswahl der Einzeldichtung entsprechend dem Isolationsdurchmesser
- MANUFACTURIN-CONDITIONED HOLE, IS STARTING FROM REV. C AT ALL VERSIONS Fertigungsbedingtes Loch, befindet sich ab Rev. C an allen Kontakten
- MARKING WITH "Ag" FOR SILVERPLATE IN CONTACT AREA Kennzeichnung mit "Ag" bei Silberueberzug im Kontaktbereich
- DIFFERENT FORM OF THE SERRATION POSSIBLE Unterschiedliche Ausfuehrung der Rillen moeglich
- PN 1241386 AND 1241392 NOT FOR NEW APPLICATION. REPLACED BY PN 1564982 AND PN1564984. PN 1241386 und 1241392 nicht fuer Neuanwendung, Ersatz durch PN 1564982 und 1564984
- DETAILS OF DESIGN ARE LEFT TO MANUFACTURER Einzelheiten der Ausfuehrung bleiben dem Hersteller ueberlassen
- FINISHED PRODUCT AT CONTACT POINTS LUBRICATED Fertigkeit an den Kontaktpunkten geschmiert
- "Ag-" MARKING ON SILVER PLATED VERSIONS FOR INCREASED LIMIT TEMPERATURE "Ag-" Markierung auf versilberten Versionen fuer erhoehte Grenztemperatur

THIS DRAWING IS A CONTROLLED DOCUMENT. DIESER ZEICHNUNGSDRUCK IST EIN KONTROLLIERTES DOKUMENT. DATE: 06 JUN 2006. DRUCKDATUM: 06. JUN. 2006. DWG: 114-18387. DWG: 114-18387. DWG: 114-18387. DWG: 114-18387.

TE Connectivity

PRODUCT GROUP DRAWING FOR AMP MCP 2.8K

SCALE: 10:1

Customer Drawing