

THIS DRAWING IS UNPUBLISHED. RELEASED FOR PUBLICATION 20
 © COPYRIGHT 20 BY - ALL RIGHTS RESERVED.

REVISIONS				
P	LTR	DESCRIPTION	DATE	APVD
D6		REVISED PER ECO-14-000579	20MAY2014	NK MM

POLARIZATION KEY SLOT

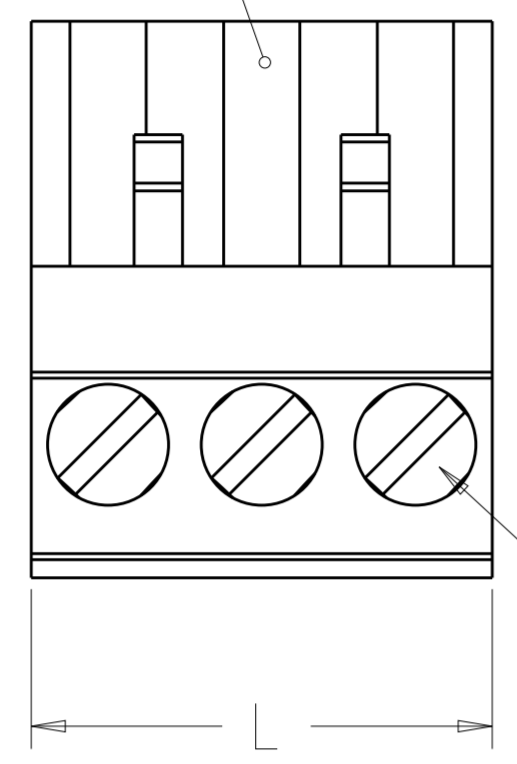

CLAMPING SCREW

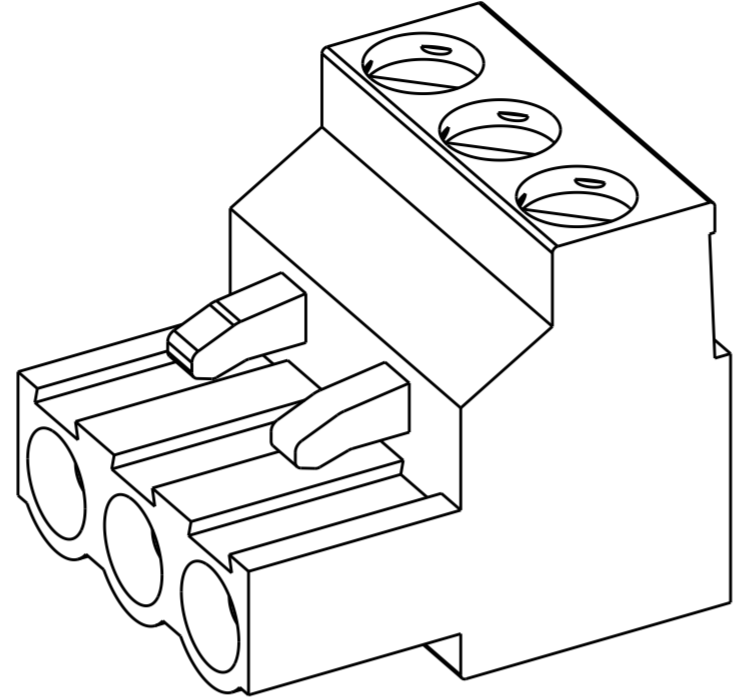

1546108-3 AS SHOWN

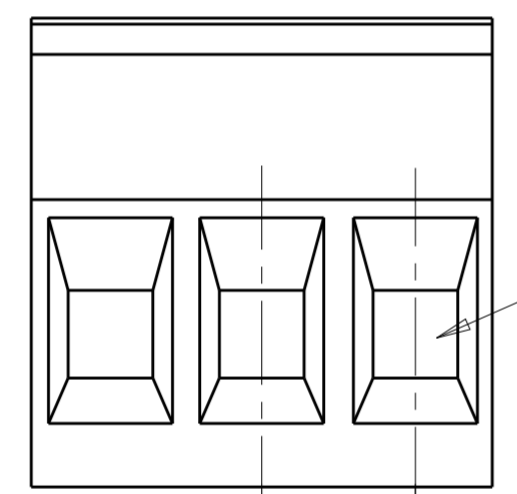

WIRE ENTRY

5.08±0.08 TYP
 2.54 REF 2 PLC

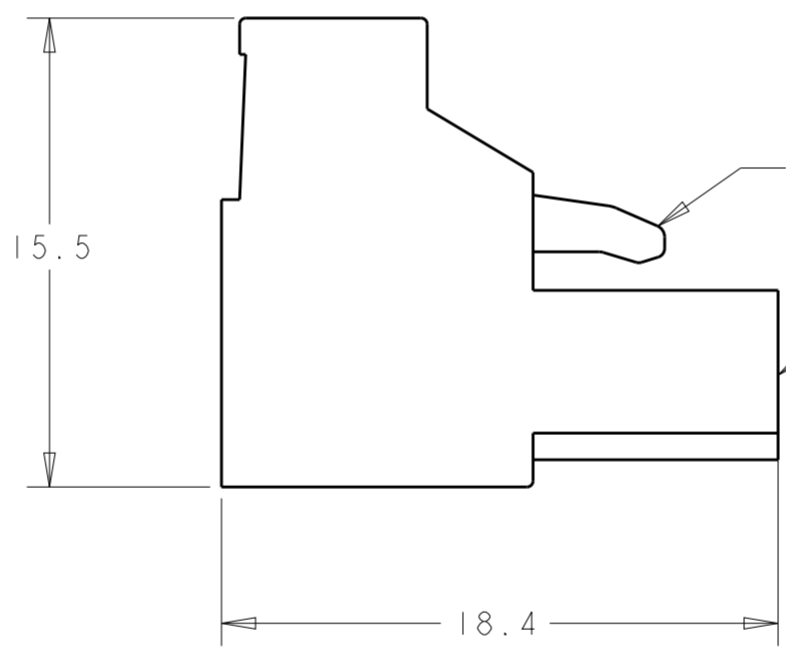

RETENTION LATCH
 MATING FACE

15.5

18.4

DETAIL H	TIN	55.88	11	6-1546108-1
DETAIL H	TIN	45.72	9	5-1546108-9
DETAIL H	TIN	30.48±0.20	6	5-1546108-6
DETAIL H	TIN	20.32±0.15	4	5-1546108-4
DETAIL H	TIN	15.24±0.15	3	5-1546108-3
DETAIL H	TIN	10.16±0.15	2	5-1546108-2
DETAIL H	TIN	60.96	12	4-1546108-7
-	TIN	15.24±0.15	3	4-1546108-6
DETAIL K	TIN	40.64	8	4-1546108-5
DETAIL H	TIN	40.64	8	4-1546108-4
DETAIL H	TIN	96.52±0.35	19	4-1546108-3
PRELIMINARY	.000030 GOLD	60.96±0.20	12	4-1546108-2
PRELIMINARY	.000030 GOLD	30.48±0.20	6	3-1546108-6
PRELIMINARY	.000030 GOLD	20.32±0.15	4	3-1546108-4
PRELIMINARY	.000030 GOLD	15.24±0.15	3	3-1546108-3
	TIN	127.00±0.35	25	2-1546108-5
	TIN	121.92±0.35	24	2-1546108-4
	TIN	116.84±0.35	23	2-1546108-3
	TIN	111.76±0.35	22	2-1546108-2
	TIN	106.68±0.35	21	2-1546108-1
	TIN	101.60±0.35	20	2-1546108-0
	TIN	96.52±0.35	19	1-1546108-9
	TIN	91.44±0.30	18	1-1546108-8
	TIN	86.36±0.30	17	1-1546108-7
	TIN	81.28±0.30	16	1-1546108-6
	TIN	76.20±0.30	15	1-1546108-5
	TIN	71.12	14	1-1546108-4
	TIN	66.04	13	1-1546108-3
	TIN	60.96	12	1-1546108-2
	TIN	55.88	11	1-1546108-1
	TIN	50.80	10	1-1546108-0
	TIN	45.72	9	1546108-9
	TIN	40.64	8	1546108-8
	TIN	35.56±0.20	7	1546108-7
	TIN	30.48±0.20	6	1546108-6
	TIN	25.40±0.20	5	1546108-5
	TIN	20.32±0.15	4	1546108-4
	TIN	15.24±0.15	3	1546108-3
	TIN	10.16±0.15	2	1546108-2
MARKING STYLE	CONTACT FINISH	L	NO OF POSN	PART NUMBER

- 1 MATERIALS AND FINISH:
 HOUSING: PA 6-6, UL 94-V0, COLOR: GRAY.
 CLAMP: BRASS, NICKEL PLATED.
 CONTACT SPRING: PHOSPHOR BRONZE, FINISH: SEE TABLE.
 CLAMPING SCREW: M3, BRASS, NICKEL PLATED.
2. END-TO-END STACKABLE WITHOUT LOSS OF CENTERLINE SPACING.
3. WIRE SIZE RANGE: 12-30 AWG.
4. RECOGNIZED UNDER THE COMPONENT PROGRAM OF UNDERWRITERS LABORATORIES INC. FILE N° E60677.
5. IMO CERTIFICATE WITH SURVEILLANCE IN CONFORMITY WITH IEC 998-1/998-2-1.
- 6 NOT CUMULATIVE TOLERANCE
7. BUCHANAN LOGO TO APPEAR ON HOUSING, LOCATION OPTIONAL WHERE SPACE PERMITS.
8. INK MARKING: BLACK COLOR. NUMERICAL SEQUENCE FROM LEFT TO RIGHT.
- 9 WITHOUT RETENTION LATCHES.

THIS DRAWING IS A CONTROLLED DOCUMENT.

DWN S. WELDON 11SEP2002
 CHK C. RICHARD 11SEP2002
 APVD C. RICHARD 11SEP2002

STE TE Connectivity

NAME: TERMINAL BLOCK, PLUG, STACKING, 5.08mm PITCH

SIZE: A2 CAGE CODE: 00779 DRAWING NO: 1546108

SCALE: 2:1 SHEET 1 OF 2 REV D6

THIS DRAWING IS UNPUBLISHED. RELEASED FOR PUBLICATION 20
 © COPYRIGHT 20 BY - ALL RIGHTS RESERVED.

LOC	DIST	REVISIONS					
FT	0	P	LTR	DESCRIPTION	DATE	DWN	APVD
		-		SEE SHEET 1	-	-	-

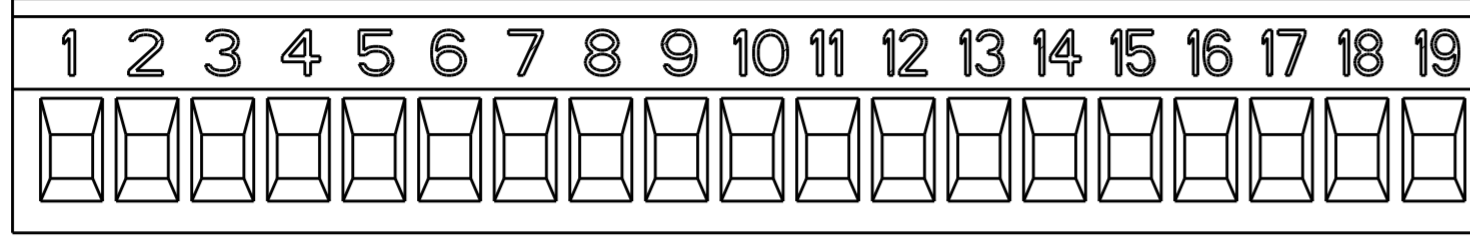

DETAIL H
SCALE 2:1

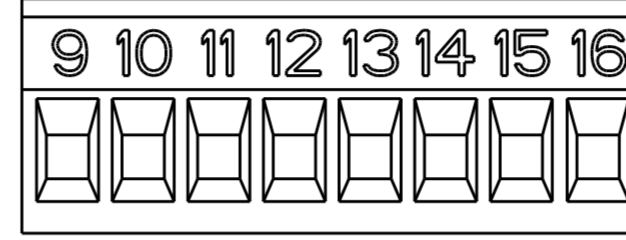

DETAIL K
SCALE 2:1

THIS DRAWING IS A CONTROLLED DOCUMENT.		DWN S. WELDON 11SEP2002	 TE Connectivity	
DIMENSIONS: mm		CHK C. RICHARD 11SEP2002		
TOLERANCES UNLESS OTHERWISE SPECIFIED:		APVD C. RICHARD 11SEP2002	NAME TERMINAL BLOCK, PLUG, STACKING, 5.08mm PITCH	
0 PLC ± 1 PLC ±0.3 2 PLC ±0.25 3 PLC ± 4 PLC ± ANGLES ± FINISH ±2		PRODUCT SPEC -	SIZE A200779	DRAWING NO C-1546108
MATERIAL -		APPLICATION SPEC -	RESTRICTED TO -	SCALE 2:1
		WEIGHT -	SHEET 2 OF 2	REV D6
		CUSTOMER DRAWING		