

THIS DRAWING IS UNPUBLISHED. RELEASED FOR PUBLICATION - N/A .
 © COPYRIGHT N/A By - ALL RIGHTS RESERVED.

LOC		DIST		REVISIONS			
P	LTR	DESCRIPTION		DATE	DWN	APVD	
	P	REV PER ECO 14-012070		8-6-14	CT	DE	

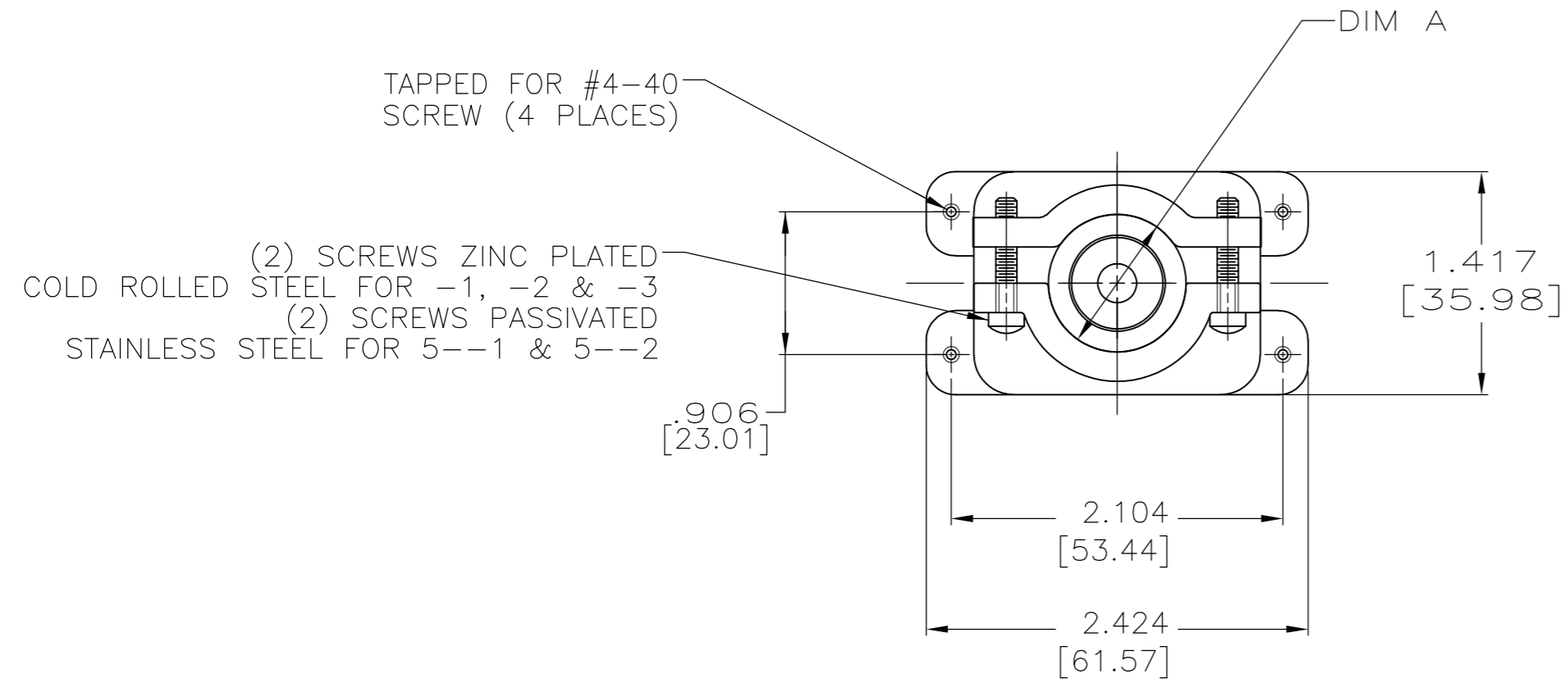

- ① ZINC PLATE PER ASTM-B-633 TYPE II CLASS 3 COLORLESS SUPPLEMENTARY CHROMATE.
- ② TWO RUBBER BUSHINGS SUPPLIED TO, PROVIDE .250 [6.35], .625 [15.88], DIAMETER OUTLETS.
- ③ AMP, AMP PART NUMBER AND DATE CODE MARKED APPROXIMATELY AS SHOWN.
- 4. SHIELD TO ACCOMMODATE MODULE RECEPTACLE ASSEMBLY OR PLUG ASSEMBLY.
- ⑤ BULK PACKAGED.
- ⑥ PLATED ELECTROLESS NICKEL PER SAE-AMS-C-26074 .000400-.000800 THK (NO INTENTIONAL ADDITIONS OF LEAD OR CADMIUM PER DFE STANDARD 230-700).

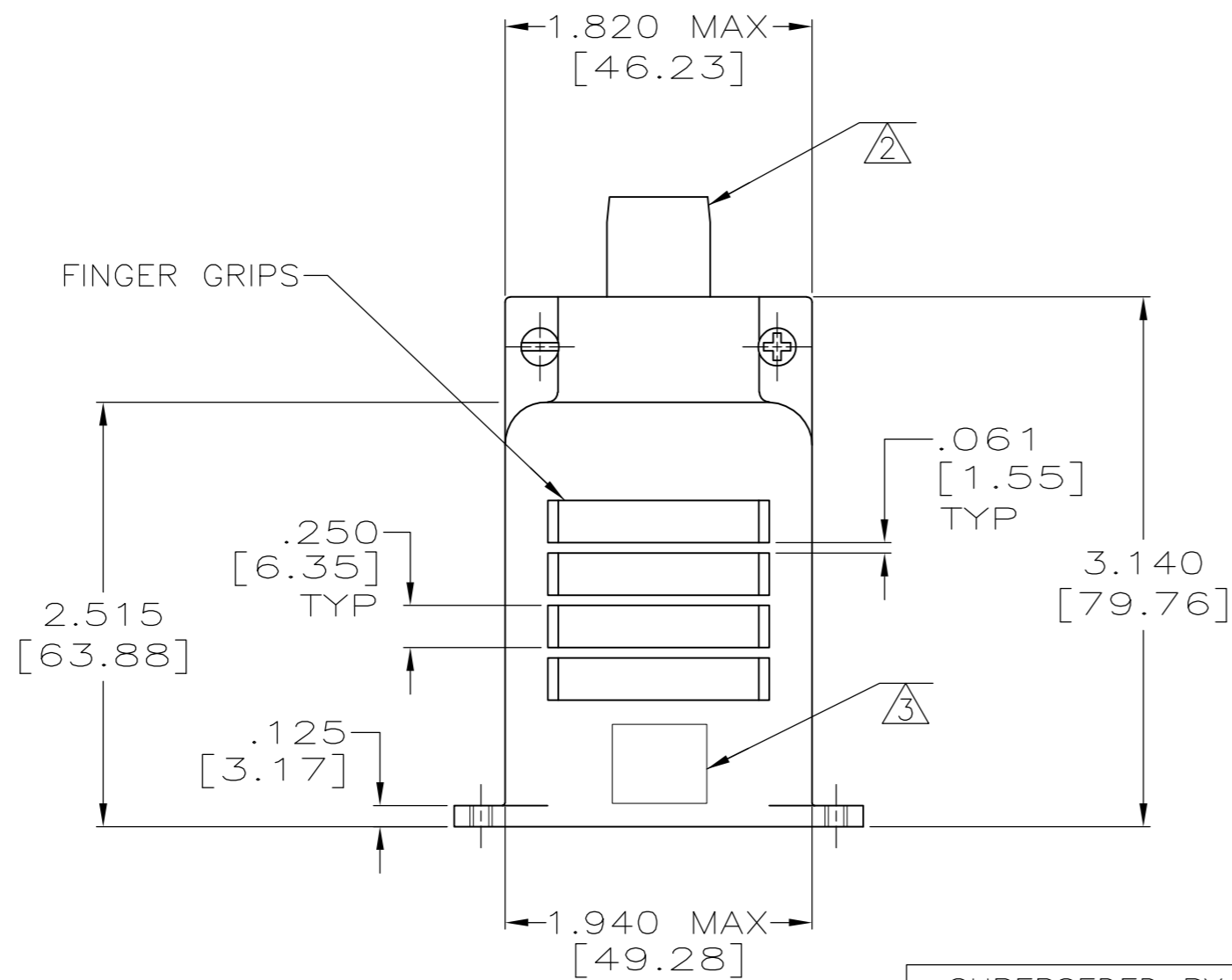

SUPERSEDED BY 5-202617-2
 SUPERSEDED BY 5-202617-1

	-	Ø.875	YES	NO	⑥	5-202617-2
OBSOLETE	-	Ø.875	YES	YES	⑥	5-202617-1
OBSOLETE	⑤	Ø.875	YES	YES	①	202617-4
OBSOLETE	-	Ø1.000	YES	NO	①	202617-3
	-	Ø.875	YES	NO	①	202617-2
	-	Ø.875	YES	YES	①	202617-1
REMARKS	DIM A	FINGER GRIPS BOTH SIDES	BUSHINGS ②	FINISH	PART NUMBER	

THIS DRAWING IS A CONTROLLED DOCUMENT.

DWN	T. THOMPSON	10-NOV-98
CHK	R. BELL	10-NOV-98
APVD	R. BELL	10-NOV-98
NAME	TE Connectivity	
PRODUCT SPEC	SHIELD FOR MODULE ASSEMBLY 2 BLOCK ASSEMBLY	
APPLICATION SPEC	SIZE	CAGE CODE
	A2	00779
MATERIAL	ALUMINUM DIE CAST PER QQ-A-591	FINISH
	SEE TABLE	WEIGHT
		-
		DRAWING NO
		C=202617
		RESTRICTED TO
		-
		SCALE
		1:1
		SHEET
		1 of 1
		REV
		P