

BY AMP INCORPORATED. ALL RIGHTS RESERVED. AMP PRODUCTS COVERED BY PATENTS AND/OR PATENTS PENDING. APPROVED PER GOVT CONTRACT NO.

REVISIONS				REVISIONS				
SYM	DESCRIPTION	DATE	APP	SYM	ZONE	DESCRIPTION	DATE	APPROVAL
K	REV PER ECO-05-005359	11-14-05	PY/DE	D		RELEASED WAS M5012-295	12-31-64	LAB B.S.H.
				A		REVISED W-524 W-421	8-2-5	M.S. RM
				B		REVISED W-777	10-14-5	M.S. D.H.
				C		REV. PER D-644	10-6-75	DE
				D		REV./ECN H-220	8-14-80	DE
				E		REV PER ECN H-203	5-12-81	DE
				F		REV PER ECN K-335	7-19-83	DE
				G		REV. PER ECN R-764	8-27-84	RG
				H		OBSOLETE -1 PER ECN R-2604	2-23-87	SDG
				J		REV PER ECO-05-001412	05/05	AA

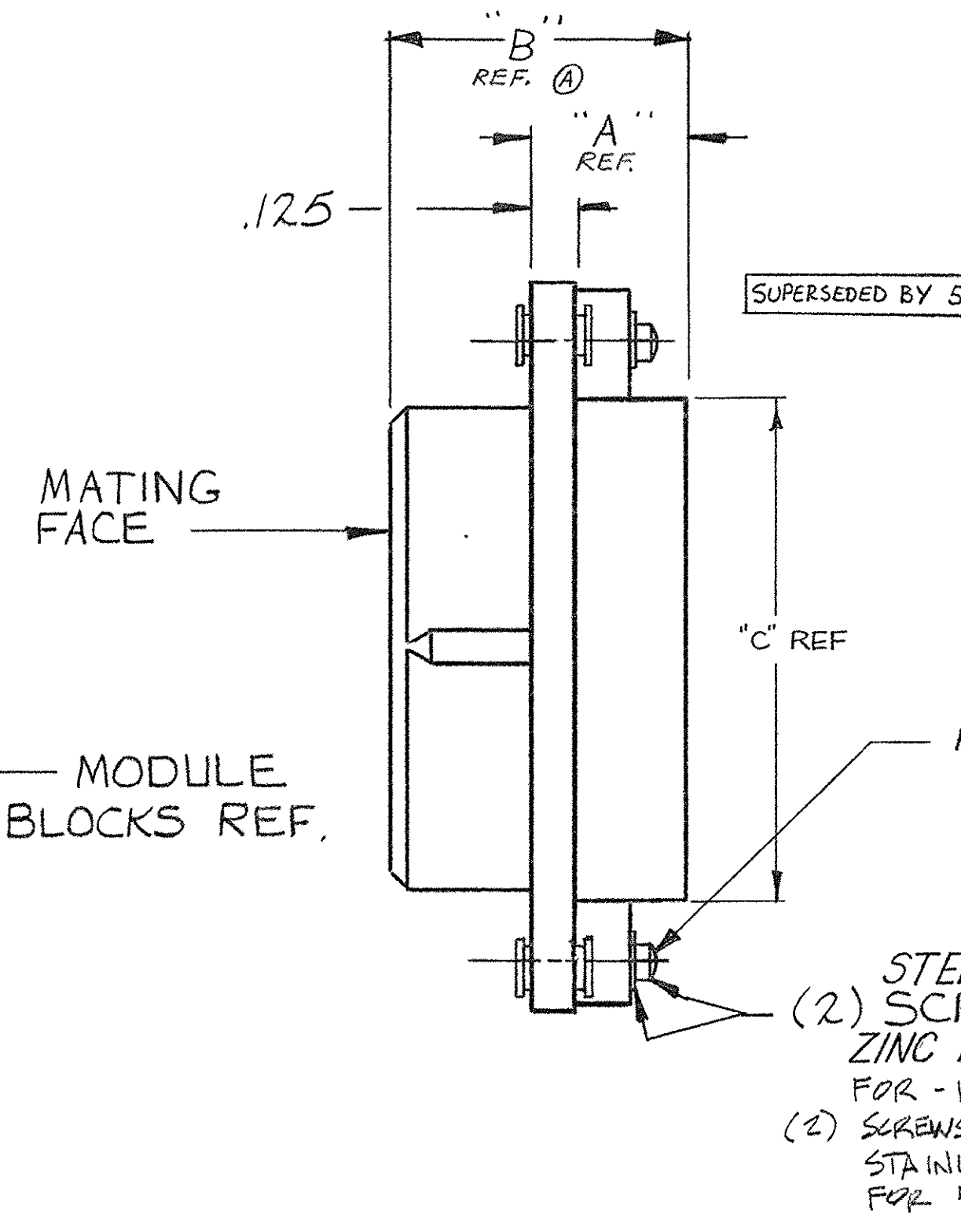
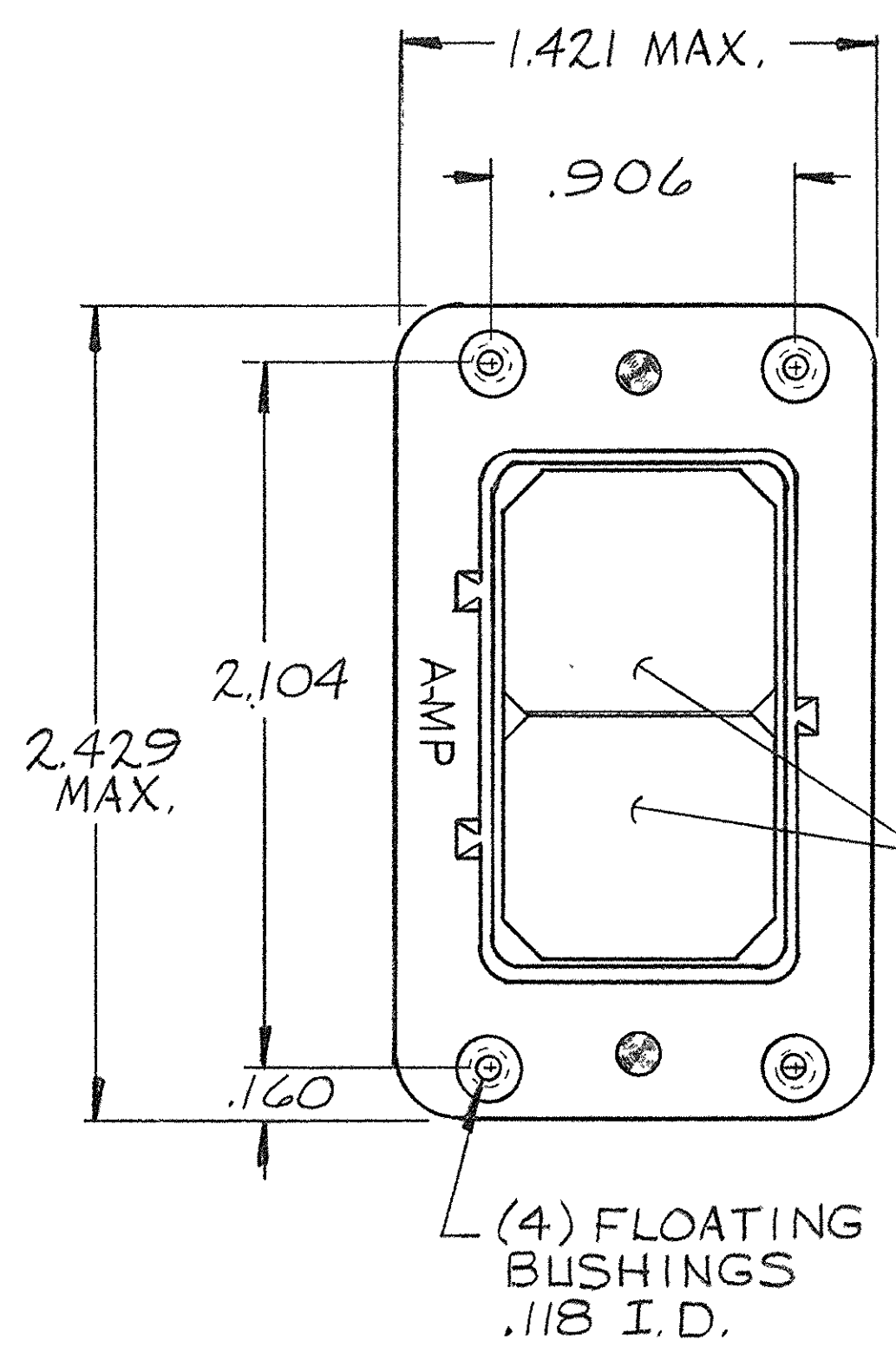

- 202680-1. OBSOLETE
- 202680-2 1. AS SHOWN.
- 202680-3 1. SAME AS -2 EXCEPT:
2. "A" AND "B" DIMENSIONS.
- 202680-4 1. SAME AS -2 EXCEPT:
2. "C" AND "D" DIMENSIONS
- 5-202680-3 1. SAME AS -3 EXCEPT:
2. PLATING

SUPERSEDED BY 5--3

MATING FACE

MODULE BLOCKS REF.

FILLISTER HEAD SCREWS

(2) STEEL SCREWS, ZINC PLATED FOR -1, -2, -3 & -4.
(2) SCREWS PASSIVATED STAINLESS STEEL FOR 5-3.

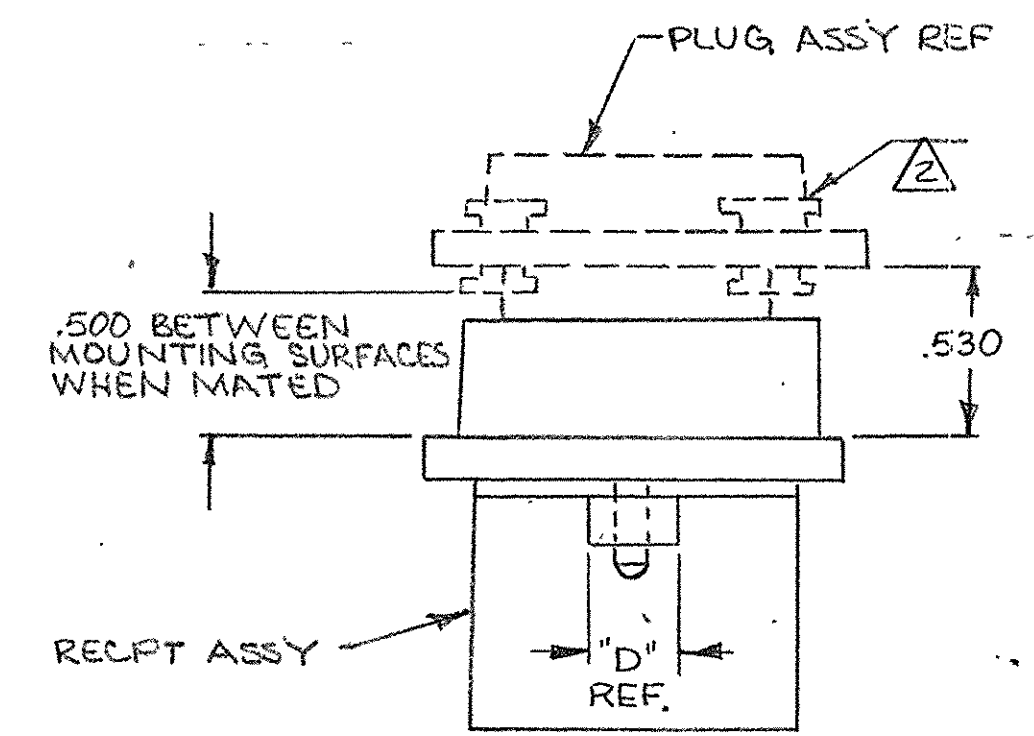

- NOTE:
- ① ZINC PLATE PER ASTM-B-633 TYPE II, CLASS 3 COLORLESS SUPPLEMENTARY CHROMATE
 - ② THE ALLOWABLE FLOAT IS .063 TO .075
 - ③ PLATING ELECTROLESS NICKEL PER SAE-AMS-C-2607A .000400 - .000300 THK (NO INTENTIONAL ADDITIONS OF LEAD OR CADMIUM PER DFE STD 230-700).

REV	DESCRIPTION	W	H	D	T	FINISH
202680-4		.480	1.010	1.569	.126	△
5-202680-3		.886	1.416	1.650	.150	△
202680-2		.480	1.010	1.650	.150	△
202680-1	OBSOLETE	.480	1.010	1.650	.150	△

LOC	PRINT DIST	QTY	NOMENCLATURE OR	①	PART OR	A	B	C	D	FINISH	
505	R 39 J	REQD	DESCRIPTION	②	IDENTIFYING NO						
UNLESS OTHERWISE SPECIFIED DIMENSIONS ARE IN INCHES		SIGNATURE		DATE		AMP INCORPORATED HARRISBURG, PENNSYLVANIA					
FRACTIONS ±	DECIMALS ±	ANGLES ±	DR			TRADEMARK					
			CHK			PLUG ASSEMBLY MODULE					
MATERIAL			DSGN ENGR			CODE IDENT NO					
DIE CAST ALUMINUM			APPD			SIZE		NUMBER			
HEAT TREAT							C		202680		
FINISH							SCALE		SHEET		
SEE NOTE 1											