

© 1965 BY AMP INCORPORATED. ALL RIGHTS RESERVED. AMP PRODUCTS COVERED BY PATENTS AND/OR PATENTS PENDING. APPROVED PER GOVT CONTRACT NO.

NUMBER 202795

REVISIONS				
SYM	ZONE	DESCRIPTION	DATE	APPROVAL
J		REV PER ECO 16-001969	CT 3-28-16	DE
B		REVISED	Y-296 3-22-66	M.S. J.H.1
C		REV PER ECN D-644	10-6-75	
D		ADDED -3 PER ECN H-373	11-5-80	EAC J.B.
E		REV. / ECN R-2305	7-20-86	MPH g.m.f.
F		OBSOLETE -3 PER ECN R-2604	2-23-87	SDG J.B.
F1		ADDED -4 PER ECN DF-0026	OCT 10-2-87	JW
G		REV PER ECO-05-001A12	AA 05/05	DR
H		REV PER ECO-05-005359	11/05	PY/DE

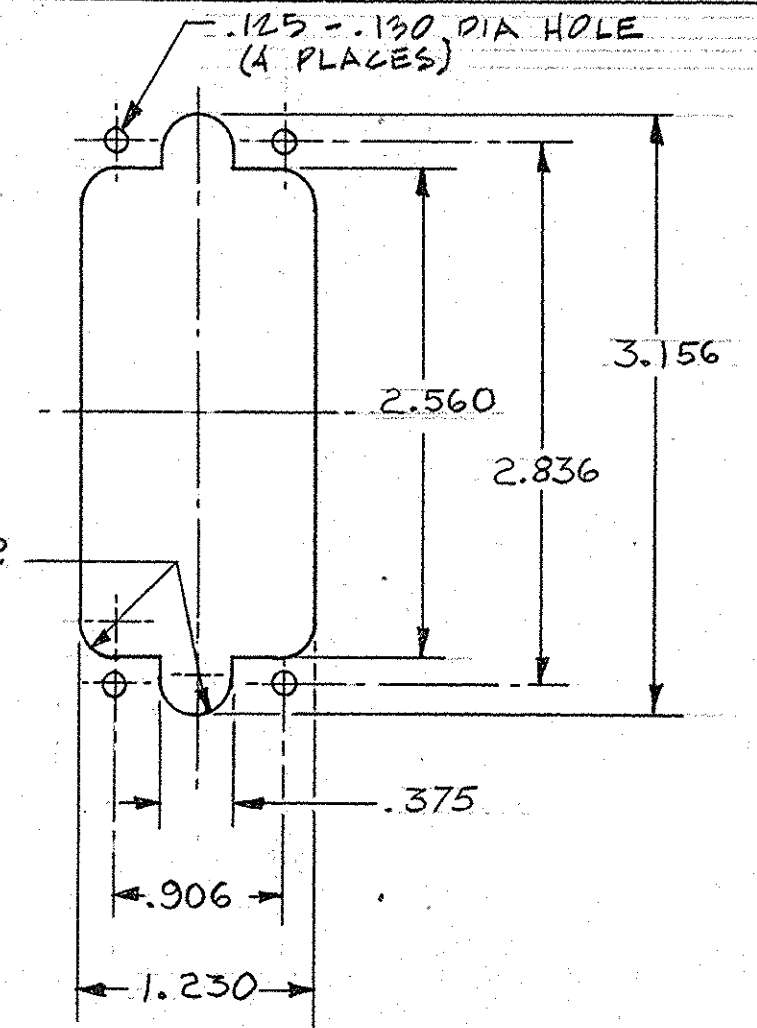
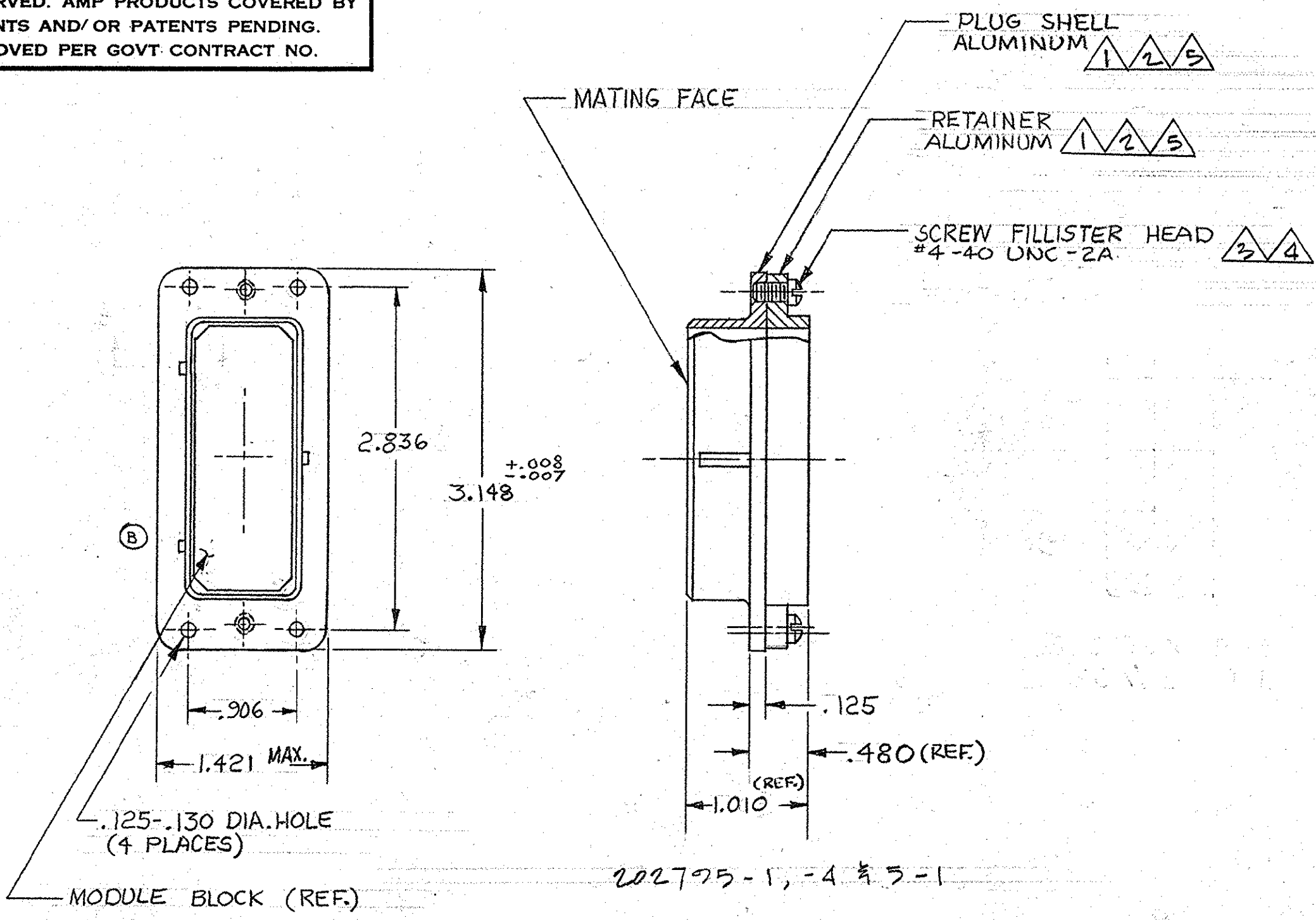

PANEL CUTOUT
SCALE: 1-1

- ① ZINC PLATE PER ASTM-B-633 TYPE II .000200-.000400 THK CLASS 3 COLORLESS SUPPLEMENTARY CHROMATE.
- ② ELECTROLESS NICKEL PLATE PER SAE-AMS-C-2607A .000400-.000800 THK (NO INTENTIONAL ADDITIONS OF LEAD OR CADMIUM PER DFE STANDARD 230-700).
- ③ ZINC PLATED COLD ROLLED STEEL.
- ④ PASSIVATED STAINLESS STEEL.
- ⑤ CADMIUM PLATE PER QQ-P-416 .000200-.000400 THK.

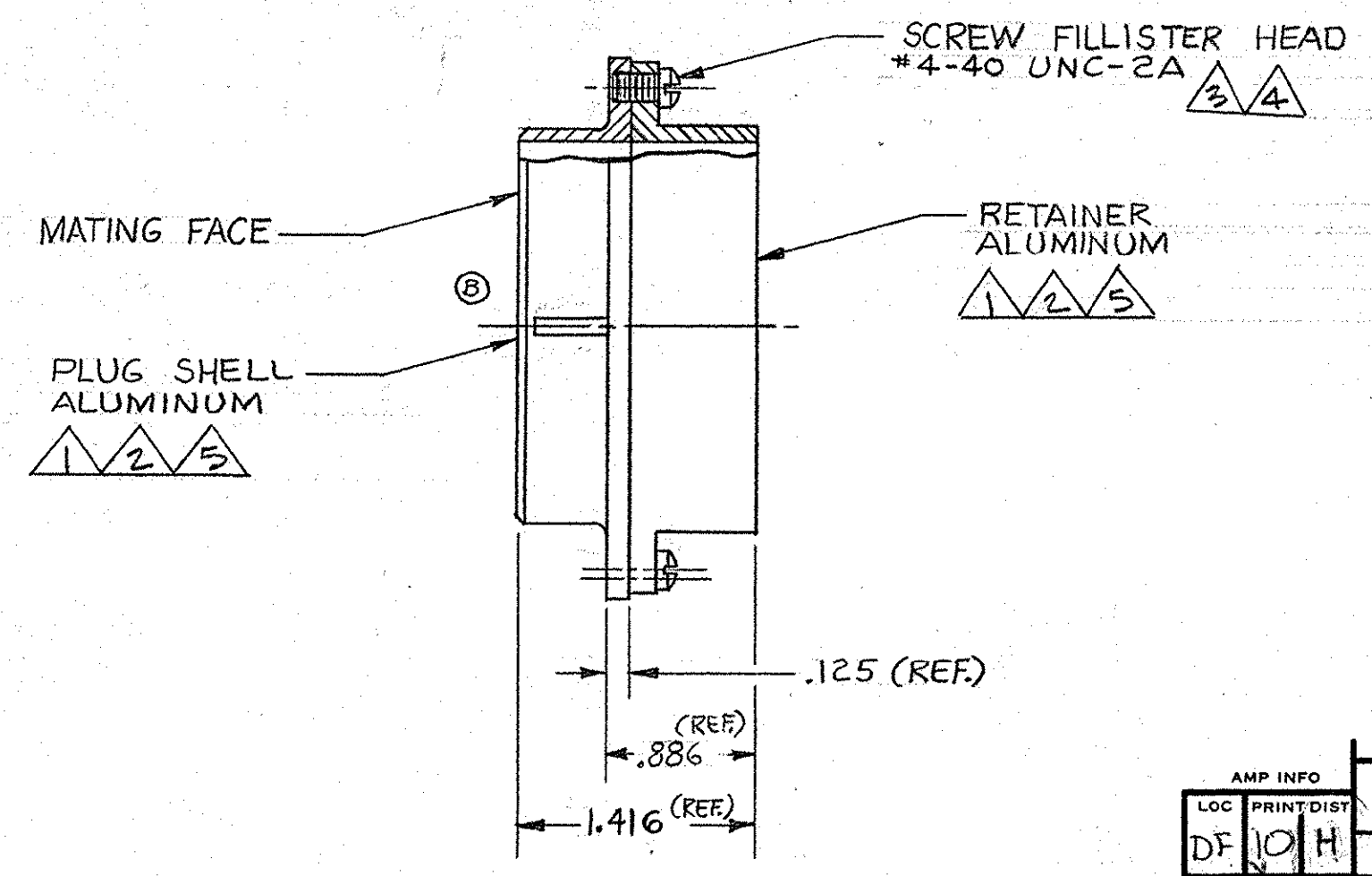

202795-2, -3 & 5-2

5-202795-2	FOR PINS	② ④	
5-202795-1	FOR SOCKETS	② ④	
202795-4	FOR SOCKETS	① ⑤	OBSOLETE
202795-3	FOR PINS	① ③	OBSOLETE
202795-2	FOR PINS	① ③	SUPERSEDED BY 5-202795-2
202795-1	FOR SOCKETS	① ③	SUPERSEDED BY 5-202795-1
PART NO.	ASSY TYPE	FINISH	

AMP INFO		QTY REQD	NOMENCLATURE OR DESCRIPTION	PART OR IDENTIFYING NO	LIST OF MATERIALS OR PARTS LIST	
LOC	PRINT/DIST					
DF	10/H					
UNLESS OTHERWISE SPECIFIED DIMENSIONS ARE IN INCHES TOLERANCES ON			SIGNATURE	DATE	AMP INCORPORATED HARRISBURG, PENNSYLVANIA	
FRACTIONS	DECIMALS	ANGLES	<i>E. Benninger</i>	10-12-65	NAME	
±	±	±	<i>J.S. Heide</i>	11-9-65	PLUG ASSEMBLY, MODULE SERIES "G" (3 BLOCKS)	
			<i>J. Williams</i>	11-9-65	CODE IDENT NO	
			<i>X.B. Miller, Jr.</i>	11-9-65	SIZE	
HEAT TREAT			DSGN APPD		NUMBER	
—					REV	
FINISH			OTHER APPD		SCALE	
SEE CALL OUT					00779 D 202795	
					WT	
					CALC	
					ACTUAL	
					SHEET	
					1 of 1	

CUSTOMER DRAWING